

Terminal Block Dual Output Signal Conditioners W5-UNIT

FREQUENCY TRANSMITTER

Functions & Features

- Converts the output from a pulse-type transducer into two isolated process signals
- Two independent output ranges
- Four-way isolation (input to output 1 to output 2 to power)
- High-density mounting

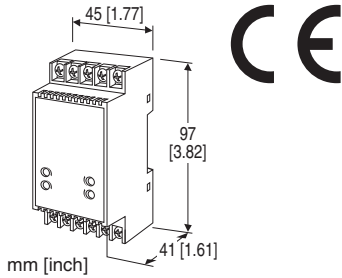

MODEL: W5PA-[1][2][3][4]-[5][6]

ORDERING INFORMATION

- Code number: W5PA-[1][2][3][4]-[5][6]
Specify a code from below for each of [1] through [6].
(e.g. W5PA-A144W4W-R/Q)
- Frequency range (e.g. 0 - 1 kHz)
- Special output ranges (For codes Z & 0)
- Specify the specification for option code /Q
(e.g. /C01/S01)

[1] INPUT

- A1: Open collector
- A2: Mechanical contact
- C: 5 V pulse (sensitivity 2 V)
- D: 12 V/24 V pulse (sensitivity 5 V)

[2] EXCITATION

- 4: 12 V DC / 30 mA
- 7: 24 V DC / 12 mA

[3] OUTPUT 1

Current

- A: 4 - 20 mA DC (Load resistance 550 Ω max.)
- B: 2 - 10 mA DC (Load resistance 1100 Ω max.)
- C: 1 - 5 mA DC (Load resistance 2200 Ω max.)
- D: 0 - 20 mA DC (Load resistance 550 Ω max.)
- E: 0 - 16 mA DC (Load resistance 685 Ω max.)
- F: 0 - 10 mA DC (Load resistance 1100 Ω max.)
- G: 0 - 1 mA DC (Load resistance 11 kΩ max.)
- Z: Specify current (See OUTPUT SPECIFICATIONS)

Voltage

- 1: 0 - 10 mV DC (Load resistance 10 kΩ min.)
- 2: 0 - 100 mV DC (Load resistance 100 kΩ min.)
- 3: 0 - 1 V DC (Load resistance 100 Ω min.)
- 4: 0 - 10 V DC (Load resistance 1000 Ω min.)
- 5: 0 - 5 V DC (Load resistance 500 Ω min.)
- 6: 1 - 5 V DC (Load resistance 500 Ω min.)
- 4W: -10 - +10 V DC (Load resistance 2000 Ω min.)
- 5W: -5 - +5 V DC (Load resistance 1000 Ω min.)
- 0: Specify voltage (See OUTPUT SPECIFICATIONS)

[4] OUTPUT 2

- Same range availability as Output 1
- Y: None

[5] POWER INPUT

AC Power

- M: 85 - 264 V AC (Operational voltage range 85 - 264 V, 47 - 66 Hz)
(CE not available)

DC Power

- R: 24 V DC
(Operational voltage range 24 V ±10 %, ripple 10 %p-p max.)
- R2: 11 - 27 V DC
(Operational voltage range 11 - 27 V, ripple 10 %p-p max.)
(CE not available)
- P: 110 V DC
(Operational voltage range 85 - 150 V, ripple 10 %p-p max.)
(CE not available)

[6] OPTIONS

- blank: none
- /Q: With options (specify the specification)

SPECIFICATIONS OF OPTION: Q (multiple selections)

COATING (For the detail, refer to M-System's web site.)

- /C01: Silicone coating
- /C02: Polyurethane coating
- /C03: Rubber coating

TERMINAL SCREW MATERIAL

- /S01: Stainless steel

CAUTION

The W5PA is designed to accept at the maximum of 100 kHz, which may cause errors due to chattering in the input pulses.

A filter circuitry (time constant: approx. 1 msec.) is incorporated to eliminate unwanted chattering when the mechanical contact input is specified. It is effective for most relay types, however, an external CR filter as indicated

below, could be added if the user needs improvement. Limit the input frequency to 10 Hz at maximum.

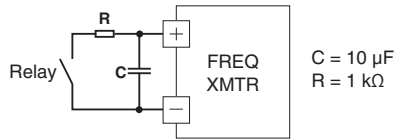

GENERAL SPECIFICATIONS

Construction: Terminal block

Connection

Input: M3.5 screw terminals (torque 0.8 N·m)

Output & power: M3 screw terminals (torque 0.8 N·m)

Screw terminal: Nickel-plated steel (standard) or stainless steel

Housing material: Flame-resistant resin (black)

Isolation: Input to output 1 to output 2 to power

Overrange output: Approx. -10 to +120 % at 1 - 5 V

Zero adjustment: -2 to +2 % (front)

(±1 % with the output suffix codes 4W and 5W selected)

Span adjustment: 98 to 102 % (front)

(99 to 101 % with the output suffix codes 4W and 5W selected.)

INPUT SPECIFICATIONS

Sensor excitation:

12 V DC; shortcircuit protection (approx. 35 mA at shortcircuit)

24 V DC; shortcircuit protection (approx. 15 mA at shortcircuit)

■ **Open Collector**

Frequency range: 0 - 0.01 Hz through 100 kHz

Pulse width time requirement: ≥ 4 µsec. for both ON and OFF

Sensing voltage/current: 5 V DC @2 mA

Detecting levels: ≤ 350 Ω / 1 V for ON; ≥ 10 kΩ / 3 V for OFF

■ **Mechanical Contact**

Frequency range: 0 - 0.01 Hz through 30 Hz

Pulse width time requirement: ≥ 10 msec. for both ON and OFF

Sensing voltage/current: 5 V DC @2 mA

Detecting levels: ≤ 350 Ω / 1 V for ON; ≥ 10 kΩ / 3 V for OFF

■ **Voltage Pulse**

Frequency range: 0 - 0.01 Hz through 100 kHz

Pulse width time requirement: ≥ 4 µsec. for both H and L levels

Waveform: Square or sine

Input impedance: ≥ 10 kΩ

Max. voltage between input terminals: ±50 V

Detecting H level

5 V pulse: ≥ 3 V

12 V, 24 V pulse: ≥ 6 V

Detecting L level

5 V pulse: ≤ 1 V

12 V, 24 V pulse: ≤ 4 V

OUTPUT SPECIFICATIONS

■ **DC Current:** 0 - 20 mA DC

Minimum span: 1 mA

Offset: Max. 1.5 times span

Load resistance: Output drive 11 V max.

■ **DC Voltage:** -10 - +12 V DC

Spans: Min. 5 mV, max. 20 V

Offset: Max. 1.5 times span

Load resistance: Output drive 10 mA max.; 5 mA for negative voltage output; at ≥ 0.5 V

INSTALLATION

Power Consumption

• **AC:**

Approx. 6 VA at 100 V

Approx. 7 VA at 200 V

Approx. 8 VA at 264 V

• **DC:** Approx. 3 W

Operating temperature: -5 to +55°C (23 to 131°F)

Operating humidity: 0 to 90 %RH (non-condensing)

Mounting: DIN rail

Weight: 130 g (0.29 lb)

PERFORMANCE in percentage of span

Accuracy: ±0.1 %

Temp. coefficient: ±0.015 %/°C (±0.008 %/°F)

Response time: Max. 0.5 sec. + 1 pulse cycle (0 - 90 %)

Line voltage effect: ±0.1 % over voltage range

Insulation resistance: ≥ 100 MΩ with 500 V DC

Dielectric strength:

2000 V AC @1 minute (input to output 1 or output 2 to power to ground)

1000 V AC @1 minute (output 1 to output 2)

STANDARDS & APPROVALS

EU conformity:

EMC Directive

EMI EN 61000-6-4

EMS EN 61000-6-2

RoHS Directive

EXTERNAL DIMENSIONS & TERMINAL ASSIGNMENTS unit: mm [inch]

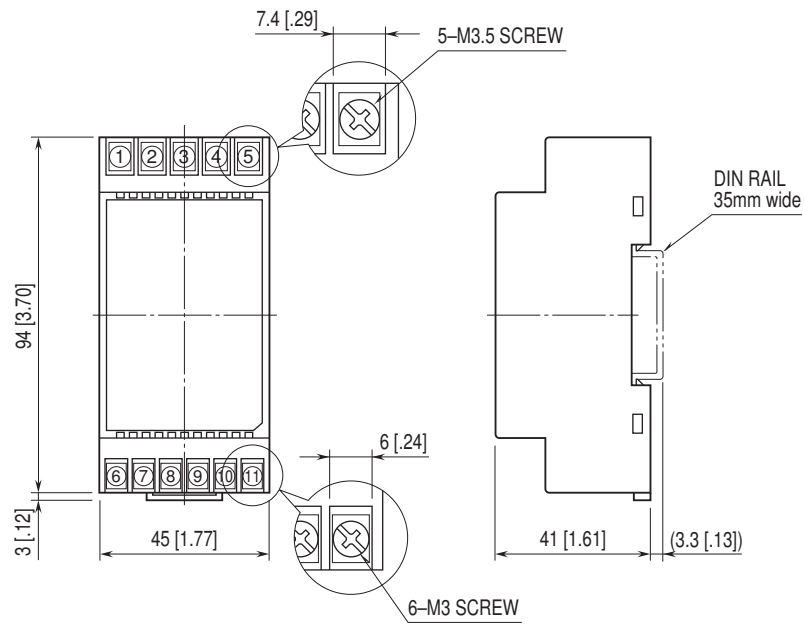

• When mounting, no extra space is needed between units.

SCHEMATIC CIRCUITRY & CONNECTION DIAGRAM

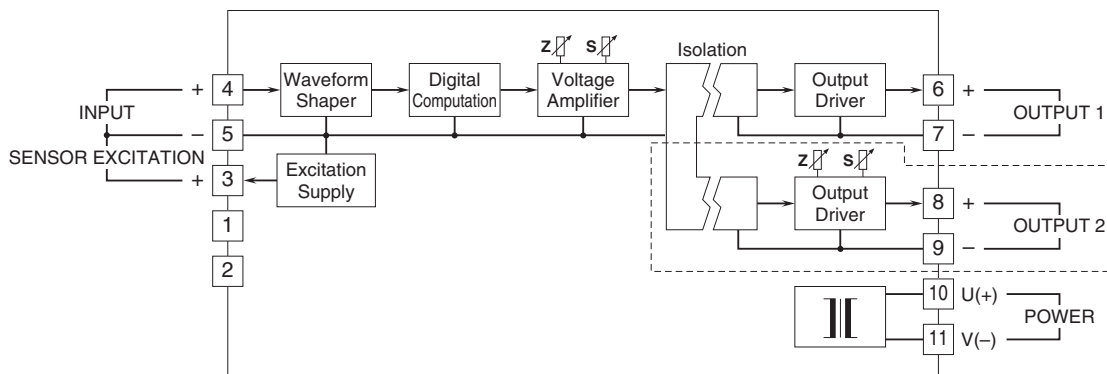

Note 1: The section enclosed by broken line is only with 2nd output option.
 Note 2: DO NOT connect to the terminals 1 and 2.

Input Connection Examples

■ Open Collector or Mechanical Contact ■ Voltage Pulse

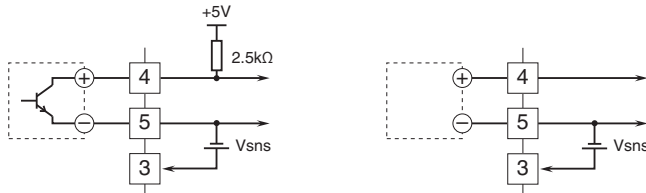

Specifications are subject to change without notice.