

Space-saving Dual Output Signal Conditioners Mini-MW Series

SIGNAL TRANSMITTER

(high speed response)

Functions & Features

- Converts DC input from a sensor into two standard process signals
- Isolation between input and output
- Two independent output ranges
- 180-microsecond response

Typical Applications

- Isolation for a vibration analyzing system

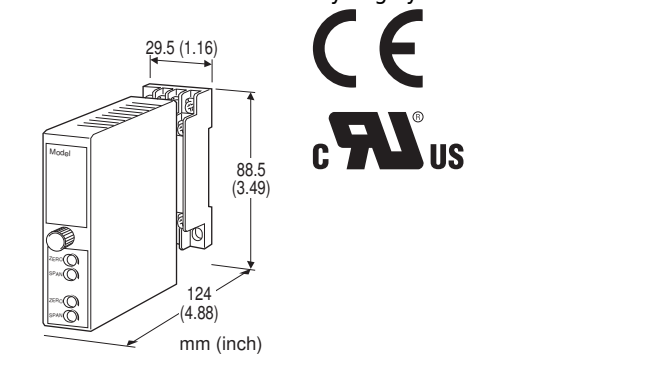

MODEL: W2VF-[1][2][3]-[4][5]

ORDERING INFORMATION

- Code number: W2VF-[1][2][3]-[4][5]
- Specify a code from below for each [1] through [5]. (e.g. W2VF-6A6-M2/CE/Q)
- Special input and output ranges (For codes Z & 0)
- Specify the specification for option code /Q (e.g. /C01/V01)

Note: If one of the outputs should be a current range, specify it for the Output 1 to allow a greater load.

[1] INPUT

Current

- A:** 4 - 20 mA DC (Input resistance 250 Ω)
- B:** 2 - 10 mA DC (Input resistance 500 Ω)
- C:** 1 - 5 mA DC (Input resistance 1000 Ω)
- D:** 0 - 20 mA DC (Input resistance 50 Ω)
- E:** 0 - 16 mA DC (Input resistance 62.5 Ω)
- F:** 0 - 10 mA DC (Input resistance 100 Ω)
- G:** 0 - 1 mA DC (Input resistance 1000 Ω)
- H:** 10 - 50 mA DC (Input resistance 100 Ω)
- GW:** -1 - +1 mA DC (Input resistance 1000 Ω)
- FW:** -10 - +10 mA DC (Input resistance 100 Ω)

Z: Specify current (See INPUT SPECIFICATIONS)

Voltage

- 3:** 0 - 1 V DC (Input resistance 1 M Ω min.)
- 4:** 0 - 10 V DC (Input resistance 1 M Ω min.)
- 5:** 0 - 5 V DC (Input resistance 1 M Ω min.)
- 6:** 1 - 5 V DC (Input resistance 1 M Ω min.)
- 4W:** -10 - +10 V DC (Input resistance 1 M Ω min.)
- 5W:** -5 - +5 V DC (Input resistance 1 M Ω min.)
- 0:** Specify voltage (See INPUT SPECIFICATIONS) (Select '/N' for 'Standards & Approvals' code.)
- 01:** Specify voltage (See INPUT SPECIFICATIONS) (Select '/CE' or '/UL' for 'Standards & Approvals' code.)

[2] OUTPUT 1

Current

- A:** 4 - 20 mA DC (Load resistance 750 Ω max.)
- B:** 2 - 10 mA DC (Load resistance 1500 Ω max.)
- C:** 1 - 5 mA DC (Load resistance 3000 Ω max.)
- D:** 0 - 20 mA DC (Load resistance 750 Ω max.)
- E:** 0 - 16 mA DC (Load resistance 900 Ω max.)
- F:** 0 - 10 mA DC (Load resistance 1500 Ω max.)
- G:** 0 - 1 mA DC (Load resistance 15 k Ω max.)
- FW:** -10 - +10 mA DC (Load resistance 700 Ω max.)
- GW:** -1 - +1 mA DC (Load resistance 7000 Ω max.)
- Z:** Specify current (See OUTPUT SPECIFICATIONS)

Voltage

- 1:** 0 - 10 mV DC (Load resistance 10 k Ω min.)
- 2:** 0 - 100 mV DC (Load resistance 100 k Ω min.)
- 3:** 0 - 1 V DC (Load resistance 1000 Ω min.)
- 4:** 0 - 10 V DC (Load resistance 10 k Ω min.)
- 5:** 0 - 5 V DC (Load resistance 5000 Ω min.)
- 6:** 1 - 5 V DC (Load resistance 5000 Ω min.)
- 4W:** -10 - +10 V DC (Load resistance 10 k Ω min.)
- 5W:** -5 - +5 V DC (Load resistance 5000 Ω min.)
- 0:** Specify voltage (See OUTPUT SPECIFICATIONS)

[3] OUTPUT 2

Y: None

Current

- A:** 4 - 20 mA DC (Load resistance 350 Ω max.)
- B:** 2 - 10 mA DC (Load resistance 700 Ω max.)
- C:** 1 - 5 mA DC (Load resistance 1400 Ω max.)
- D:** 0 - 20 mA DC (Load resistance 350 Ω max.)
- E:** 0 - 16 mA DC (Load resistance 430 Ω max.)
- F:** 0 - 10 mA DC (Load resistance 700 Ω max.)
- G:** 0 - 1 mA DC (Load resistance 7000 Ω max.)
- FW:** -10 - +10 mA DC (Load resistance 700 Ω max.)
- GW:** -1 - +1 mA DC (Load resistance 7000 Ω max.)
- Z:** Specify current (See OUTPUT SPECIFICATIONS)

Voltage

Same range availability as Output 1

[4] POWER INPUT**AC Power**

M: 85 – 264 V AC (Operational voltage range 85 – 264 V, 47 – 66 Hz)

(Select '/N' for 'Standards & Approvals' code.)

M2: 100 – 240 V AC (Operational voltage range 85 – 264 V, 47 – 66 Hz)

(90 – 264 V for UL)

DC Power

R: 24 V DC

(Operational voltage range 24 V \pm 10 %, ripple 10 %p-p max.)

R2: 11 – 27 V DC

(Operational voltage range 11 – 27 V, ripple 10 %p-p max.)

(Select '/N' for 'Standards & Approvals' code.)

P: 110 V DC

(Operational voltage range 85 – 150 V, ripple 10 %p-p max.)

(Select '/N' for 'Standards & Approvals' code.)

[5] OPTIONS (multiple selections)**Standards & Approvals (must be specified)**

/N: Without CE or UL

/CE: CE marking

/UL: UL approval, CE marking

Other Options

blank: none

/Q: Option other than the above (specify the specification)

SPECIFICATIONS OF OPTION: Q (multiple selections)**COATING (For the detail, refer to M-System's web site.)**

/C01: Silicone coating

/C02: Polyurethane coating

/C03: Rubber coating (UL not available)

ADJUSTMENT

/V01: Multi-turn fine adjustment (UL not available)

TERMINAL SCREW MATERIAL

/S01: Stainless steel (UL not available)

GENERAL SPECIFICATIONS

Construction: Plug-in

Connection: M3 screw terminals (torque 0.8 N·m)

Screw terminal: Chromated steel (standard) or stainless steel

Housing material: Flame-resistant resin (black)

Isolation: Input to output 1 to output 2 to power

Overrange output: Approx. -10 to +120 % at 1 – 5 V

Zero adjustment: -5 to +5 % (front)

Span adjustment: 95 to 105 % (front)

Adjustable individually for each output 1 and output 2.

INPUT SPECIFICATIONS**■ DC Current:**

Shunt resistor attached to the input terminals (0.5 W)

Specify input resistance value for code Z.

■ DC Voltage: -300 – +300 V DC

(-30 – +30 V for the input code 01. Span 30 V max.)

Minimum span: 1 V

Offset: Max. 1.5 times span

Input resistance: \geq 1 M Ω

OUTPUT SPECIFICATIONS**■ DC Current:** -10 – +20 mA DC

Minimum span: 1 mA

Offset: Max. 1.5 times span

Load resistance: Output drive 15 V max. for Output 1; 7 V max. for Output 2 (7 V for both outputs for bidirectional outputs)

■ DC Voltage: -10 – +12 V DC (up to 10 V for Output 2)

Minimum span: 5 mV

Offset: Max. 1.5 times span

Load resistance: Output drive 1 mA max.; at \geq 0.5 V

INSTALLATION**Power Consumption****•AC:**

Approx. 4 VA at 100 V

Approx. 5 VA at 200 V

Approx. 6 VA at 240 V

•DC: Approx. 3 W

Operating temperature: -5 to +55°C (23 to 131°F)

Operating humidity: 30 to 90 %RH (non-condensing)

Mounting: Surface or DIN rail

Weight: 200 g (0.44 lb)

PERFORMANCE in percentage of span

Accuracy: \pm 0.1 %

Temp. coefficient: \pm 0.015 %/°C (\pm 0.008 %/°F)

Response time: \leq 180 μ sec. (0 – 90 %)

Line voltage effect: \pm 0.1 % over voltage range

Insulation resistance: \geq 100 M Ω with 500 V DC

Dielectric strength: 2000 V AC @1 minute (input or output1 or output 2 to power to ground)

1000 V AC @1 minute (input to output 1 to output 2)

STANDARDS & APPROVALS

EU conformity:

EMC Directive

EMI EN 61000-6-4

EMS EN 61000-6-2

Low Voltage Directive

EN 61010-1

Installation Category II

Pollution Degree 2

Input or output 1 or output 2 to power input: Reinforced insulation (300 V)

Input to output 1 to output 2: Functional insulation

RoHS Directive

EN 50581

Approval:

UL/C-UL nonincendive Class I, Division 2,

Groups A, B, C, and D

(ANSI/ISA-12.12.01, CAN/CSA-C22.2 No.213)

UL/C-UL general safety requirements

(UL 61010-1, CAN/CSA-C22.2 No.61010-1)

EXTERNAL DIMENSIONS unit: mm (inch)

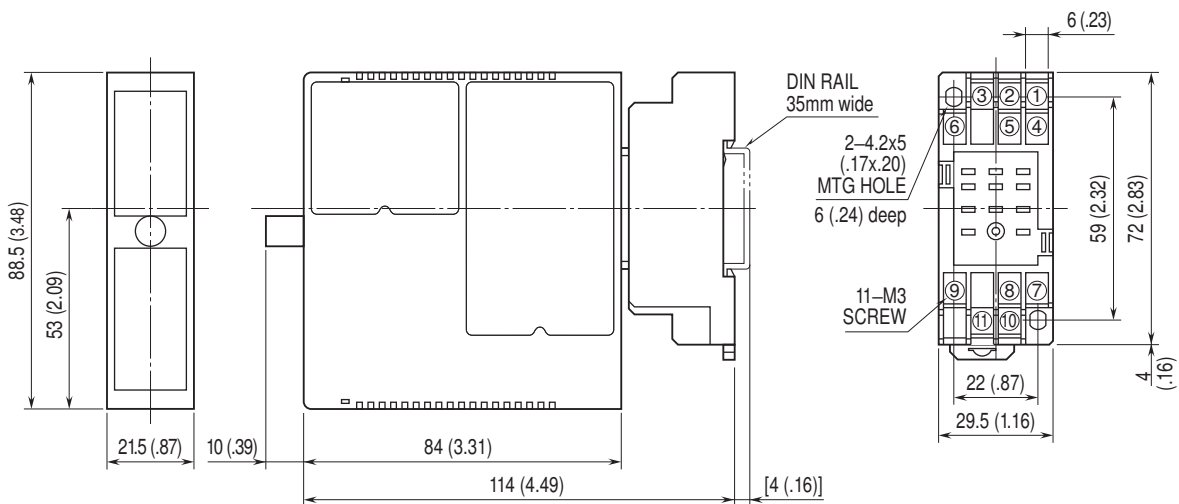

• When mounting, no extra space is needed between units.

TERMINAL ASSIGNMENTS unit: mm (inch)

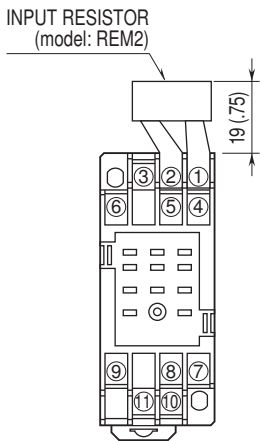

Input shunt resistor attached for current input.

SCHEMATIC CIRCUITRY & CONNECTION DIAGRAM

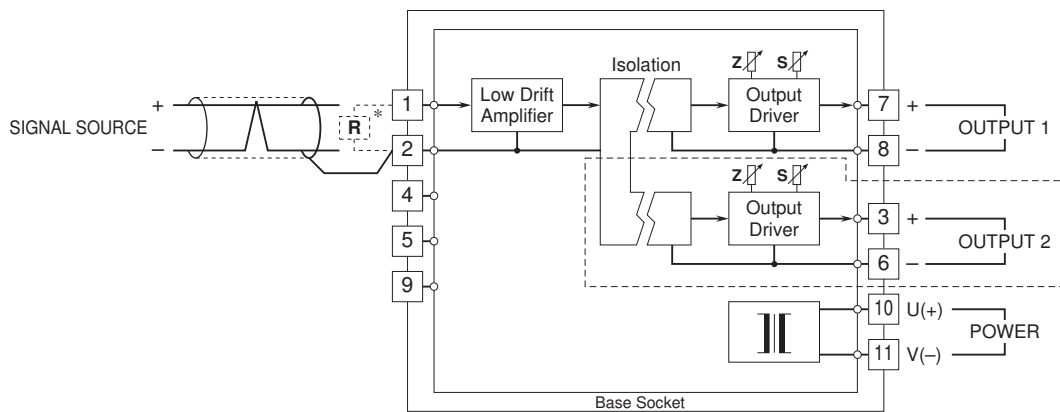

*Input shunt resistor attached for current input.
 Note: The section enclosed by broken line is only with 2nd output option.

The W2VF, by its fast-response feature, is not designed to eliminate noise present in the input signal. Use a shielded twisted-pair cable for preventing noise entering through the input wiring.

 Specifications are subject to change without notice.