

Remote I/O R7K4D Series

/C03: Rubber coating

MECHATROLINK I/O MODULE

(PNP discrete input, 32 points, e-CON connector, MECHATROLINK- I/- II use)

Functions & Features

- 32 points PNP discrete input module for MECHATROLINK- I/- II

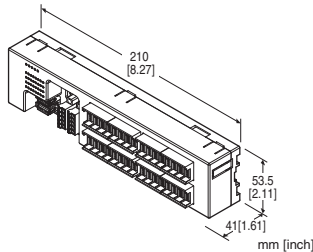

MODEL: R7K4DML-B-DA32B-R[1]

ORDERING INFORMATION

- Code number: R7K4DML-B-DA32B-R[1]
Specify a code from below for [1].
(e.g. R7K4DML-B-DA32B-R/Q)
- Specify the specification for option code /Q
(e.g. /C01)

TERMINAL BLOCK

B: Tension clamp terminal block for power supply
Connector for MECHATROLINK- I/- II for communication
e-CON connector for I/O

I/O TYPE

DA32B: PNP discrete input, 32 points

POWER INPUT

DC Power

R: 24 V DC

(Operational voltage range 24 V \pm 10 %, ripple 10 %p-p max.)

[1] OPTIONS

blank: none

/Q: With options (specify the specification)

SPECIFICATIONS OF OPTION: Q

COATING (For the detail, refer to M-System's web site.)

/C01: Silicone coating

/C02: Polyurethane coating

GENERAL SPECIFICATIONS

Connection

MECHATROLINK: MECHATROLINK- I/- II connector

Power & Sensor excitation: Separable screwless spring terminal

Input: e-CON connector

Housing material: Flame-resistant resin (gray)

Isolation: Input or sensor excitation to MECHATROLINK or FE to power

Status indicator LED: PWR, ERR, SD, RD

(Refer to the instruction manual for details)

Discrete input status indicator LED: Green LED turns on with input ON

MECHATROLINK COMMUNICATION

MECHATROLINK mode: Set with DIP switches

(MECHATROLINK-I or -II, data length; Factory setting:

MECHATROLINK-II, data length 32 byte)

(Refer to the instruction manual)

Station address: 60H - 7FH

(Function selected with Rotary SW. Factory setting: 61H).

(Refer to the instruction manual)

MECHATROLINK-I

Baud rate: 4 Mbps

Transmission distance: 50 m max.

Distance between stations: 30 cm min.

Transmission media: MECHATROLINK cable (Model JEPMC-W6003-x-E, Yaskawa Controls Co., Ltd.)

Max. number of slaves: 15

(The maximum number of slaves might change depending on the master unit. Refer to the manual of the master unit.)

Transmission cycle: 2 msec. (fixed)

Data length: 17 byte

MECHATROLINK-II

Baud rate: 10 Mbps

Transmission distance: 50 m max.

Distance between stations: 50 cm min.

Transmission media: MECHATROLINK cable (Model JEPMC-W6003-x-E, Yaskawa Controls Co., Ltd.)

Max. number of slaves: 30

(The maximum number of slaves might change depending on the master unit. Refer to the manual of the master unit.)

Transmission cycle: 0.25 msec., 0.5 msec., 1 msec., 1.5 msec., 2 msec., 2.5 msec., 3 msec., 4 msec., 8 msec.

Data length: 17 byte / 32 byte selectable (Must choose identical data size for all stations within the network)

INPUT SPECIFICATIONS

Common: Negative common (PNP) per 32 points
Maximum inputs applicable at once: No limit (at 24V DC)
Sensor excitation: 24 V DC $\pm 10\%$; ripple 5 %p-p max.,
 ≤ 2 A (including discrete input load charge); rated current
8 A
ON voltage / current: ≥ 18 V DC (X0 through X1F to GND) /
 ≥ 2.0 mA
OFF voltage / current: ≤ 9 V DC (X0 through X1F to GND) /
 ≤ 1.0 mA
Input current: ≤ 3.0 mA per point at 24 V DC
Input resistance: Approx. 8.6 k Ω
ON delay: ≤ 0.5 msec.
OFF delay: ≤ 1.0 msec.

INSTALLATION

Current consumption: Approx. 60 mA (rated current 2 A)
Operating temperature: 0 to 55°C (32 to 131°F)
Storage temperature: -20 to +65°C (-4 to +149°F)
Operating humidity: 30 to 90 %RH (non-condensing)
Atmosphere: No corrosive gas or heavy dust
Mounting: Surface or DIN rail (35 mm rail)
Weight: 200 g (0.44 lb)

PERFORMANCE

Insulation resistance: ≥ 100 M Ω with 500 V DC
Dielectric strength: 1500 V AC @ 1 minute
(input or sensor excitation to power)
500 V AC @ 1 minute (MECHATROLINK or FE to input or
sensor excitation or power)

STANDARDS & APPROVALS

EU conformity:
EMC Directive
EMI EN 61000-6-4
EMS EN 61000-6-2
RoHS Directive

EXTERNAL VIEW

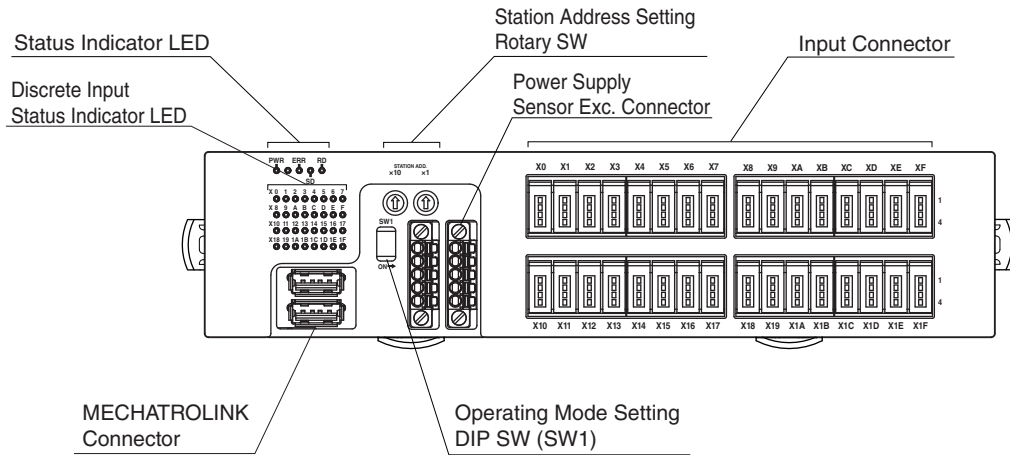

TERMINAL ASSIGNMENTS

■ INPUT TERMINAL ASSIGNMENT

- e-CON connector

Recommended cable connector: 37104-()-000FL (3M Company)

(The cable connector is not included in the package. Specify wire size instead of (); refer to the specifications of the product.)

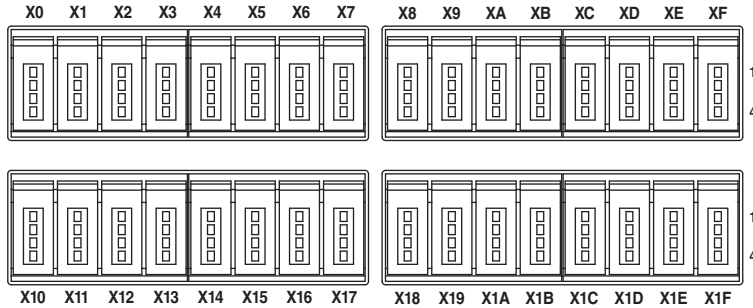

No.	ID	FUNCTION	No.	ID	FUNCTION
X0	1	+24V 24V DC	X8	1	+24V 24V DC
	2	NC Unused		2	NC Unused
	3	GND 0V		3	GND 0V
	4	X0 Input 0		4	X8 Input 8
X1	1	+24V 24V DC	X9	1	+24V 24V DC
	2	NC Unused		2	NC Unused
	3	GND 0V		3	GND 0V
	4	X1 Input 1		4	X9 Input 9
X2	1	+24V 24V DC	XA	1	+24V 24V DC
	2	NC Unused		2	NC Unused
	3	GND 0V		3	GND 0V
	4	X2 Input 2		4	XA Input 10
X3	1	+24V 24V DC	XB	1	+24V 24V DC
	2	NC Unused		2	NC Unused
	3	GND 0V		3	GND 0V
	4	X3 Input 3		4	XB Input 11
X4	1	+24V 24V DC	XC	1	+24V 24V DC
	2	NC Unused		2	NC Unused
	3	GND 0V		3	GND 0V
	4	X4 Input 4		4	XC Input 12
X5	1	+24V 24V DC	XD	1	+24V 24V DC
	2	NC Unused		2	NC Unused
	3	GND 0V		3	GND 0V
	4	X5 Input 5		4	XD Input 13
X6	1	+24V 24V DC	XE	1	+24V 24V DC
	2	NC Unused		2	NC Unused
	3	GND 0V		3	GND 0V
	4	X6 Input 6		4	XE Input 14
X7	1	+24V 24V DC	XF	1	+24V 24V DC
	2	NC Unused		2	NC Unused
	3	GND 0V		3	GND 0V
	4	X7 Input 7		4	XF Input 15

No.	ID	FUNCTION	No.	ID	FUNCTION
X10	1	+24V 24V DC	X18	1	+24V 24V DC
	2	NC Unused		2	NC Unused
	3	GND 0V		3	GND 0V
	4	X10 Input 16		4	X18 Input 24
X11	1	+24V 24V DC	X19	1	+24V 24V DC
	2	NC Unused		2	NC Unused
	3	GND 0V		3	GND 0V
	4	X11 Input 17		4	X19 Input 25
X12	1	+24V 24V DC	X1A	1	+24V 24V DC
	2	NC Unused		2	NC Unused
	3	GND 0V		3	GND 0V
	4	X12 Input 18		4	X1A Input 26
X13	1	+24V 24V DC	X1B	1	+24V 24V DC
	2	NC Unused		2	NC Unused
	3	GND 0V		3	GND 0V
	4	X13 Input 19		4	X1B Input 27
X14	1	+24V 24V DC	X1C	1	+24V 24V DC
	2	NC Unused		2	NC Unused
	3	GND 0V		3	GND 0V
	4	X14 Input 20		4	X1C Input 28
X15	1	+24V 24V DC	X1D	1	+24V 24V DC
	2	NC Unused		2	NC Unused
	3	GND 0V		3	GND 0V
	4	X15 Input 21		4	X1D Input 29
X16	1	+24V 24V DC	X1E	1	+24V 24V DC
	2	NC Unused		2	NC Unused
	3	GND 0V		3	GND 0V
	4	X16 Input 22		4	X1E Input 30
X17	1	+24V 24V DC	X1F	1	+24V 24V DC
	2	NC Unused		2	NC Unused
	3	GND 0V		3	GND 0V
	4	X17 Input 23		4	X1F Input 31

■ POWER SUPPLY, SENSOR EXCITATION

Cable connector: FMC1,5 / 5-STF-3,5

(Phoenix Contact) (included in the package)

Applicable wire size: 0.2 – 1.5 mm²; stripped length 10 mm

Recommended solderless terminal

- AI0,25-10YE 0.25 mm² (Phoenix Contact)
- AI0,34-10TQ 0.34 mm² (Phoenix Contact)
- AI0,5-10WH 0.5 mm² (Phoenix Contact)
- AI0,75-10GY 0.75 mm² (Phoenix Contact)
- A1-10 1.0 mm² (Phoenix Contact)
- A1,5-10 1.5 mm² (Phoenix Contact)

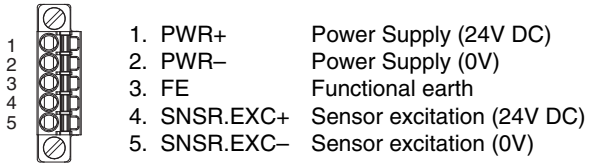

■ MECHATROLINK CONNECTION

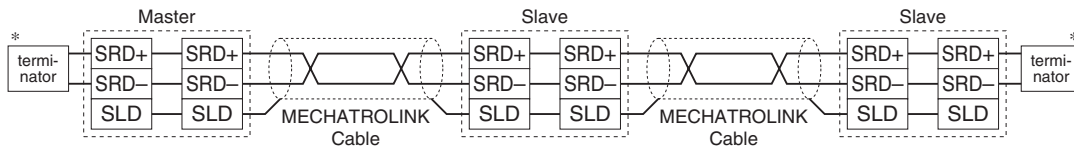

*Terminator

Be sure to connect the terminating resistors to the unit at both ends of transmission line.

Use the terminating resistor dedicated for MECHATROLINK: Model JEPMC-W6022, Yaskawa Controls Co., Ltd.

Certain types of Master units may have incorporated terminating resistors. Consult the instruction manual of the Master unit.

MECHATROLINK RELATED COMMANDS

R7K4DML (Simple I/O) communicates with I/O service with no processor, therefore it uses a connectionless communication protocol. There is no application layer either; the R7K4DML interchanges I/O data via data link layer.

■ MECHATROLINK DATA LINK LAYER COMMAND DESCRIPTIONS

The following tables explain the two Commands supported by the R7K4DML.

• MDS Command (04H) Data Format

BYTE	COMMAND	RESPONSE	REMARKS
0	MDS (04H)	S(0) (90H)	Message Data Search (MDS) Command: Read the ID from slave station(s) S(0): Response to MDS
1	0	ID	
2	0		
3	0		
4	0	0	All 0
5	0	0	
6	0	0	
7	0	0	
8	0	0	
9	0	0	
10	0	0	
11	0	0	
12	0	0	
13	0	0	
14	0	0	
15	0	0	
16	0	0	
17	0	0	Byte 17 through 31 are always 0 in the 32-byte mode. These bytes are unavailable for MECHATROLINK-I and MECHATROLINK-II in the 17-byte mode.
:	:	:	
31	0	0	

• CDRW Command (03H) Data Format

BYTE	COMMAND	RESPONSE	REMARKS
0	CDRW (03H)	ACK (01H)	Cyclic Data Read/Write (CDRW) Command: Link transmission Acknowledge (ACK): Positive response to CDRW
1	Out Data: Lowest	In Data: Lowest	Order of data: Little Endian
2			
3			
4			
5			
6			
7			
8			
9			
10			
11			
12			
13			
14			
15			
16			
17	(Out Data: Highest)	(In Data: Highest)	Byte 17 through 31 are unavailable for MECHATROLINK-I and MECHATROLINK-II in the 17-byte mode. (Only available for MECHATROLINK-II in the 32-byte mode)
:			
31			

I/O DATA DESCRIPTIONS

■ 17-BYTE MODE

•32 points input data (In Data)

Byte	Bit7	Bit6	Bit5	Bit4	Bit3	Bit2	Bit1	Bit0
1	In7	In6	In5	In4	In3	In2	In1	In0
2	In15	In14	In13	In12	In11	In10	In9	In8
3	In23	In22	In21	In20	In19	In18	In17	In16
4	In31	In30	In29	In28	In27	In26	In25	In24
5	0	0	0	0	0	0	0	0
⋮	0	0	0	0	0	0	0	0
12	0	0	0	0	0	0	0	0
13	0	0	0	0	0	0	0	0
14	0	0	0	0	0	0	0	0
15	0	0	0	0	0	0	0	0
16	0	0	0	0	0	0	0	0

■ 32-BYTE MODE

•32 points input data (In Data)

Byte	Bit7	Bit6	Bit5	Bit4	Bit3	Bit2	Bit1	Bit0
1	In7	In6	In5	In4	In3	In2	In1	In0
2	In15	In14	In13	In12	In11	In10	In9	In8
3	In23	In22	In21	In20	In19	In18	In17	In16
4	In31	In30	In29	In28	In27	In26	In25	In24
5	0	0	0	0	0	0	0	0
⋮	0	0	0	0	0	0	0	0
28	0	0	0	0	0	0	0	0
29	0	0	0	0	0	0	0	0
30	0	0	0	0	0	0	0	0
31	0	0	0	0	0	0	0	0
32	0	0	0	0	0	0	0	0

0: OFF, 1: ON

EXTERNAL DIMENSIONS unit: mm [inch]

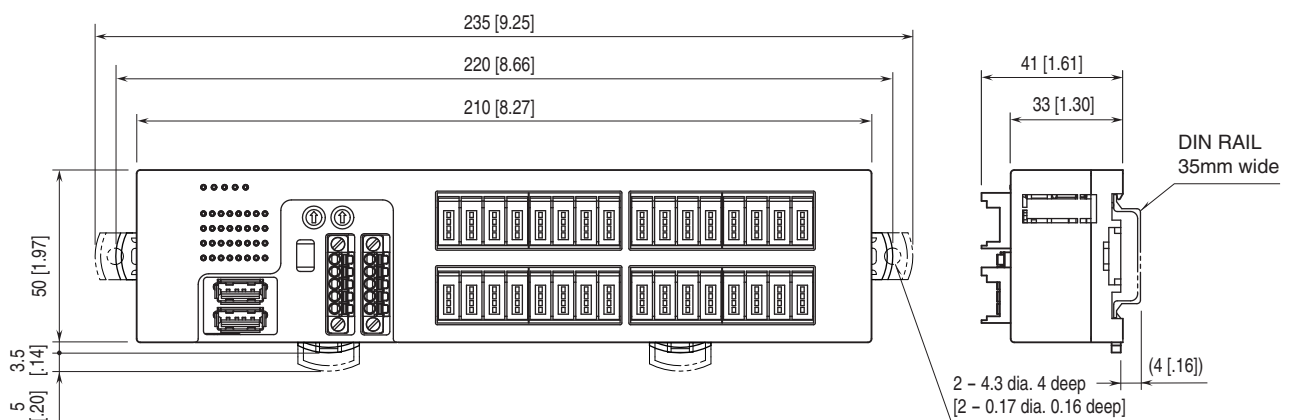

MOUNTING REQUIREMENTS unit: mm [inch]

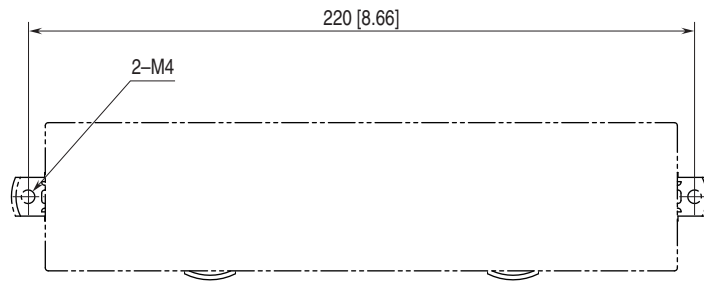

SCHEMATIC CIRCUITRY & CONNECTION DIAGRAM

Note: In order to improve EMC performance, bond the FE terminal to ground.

Caution: FE terminal is NOT a protective conductor terminal.

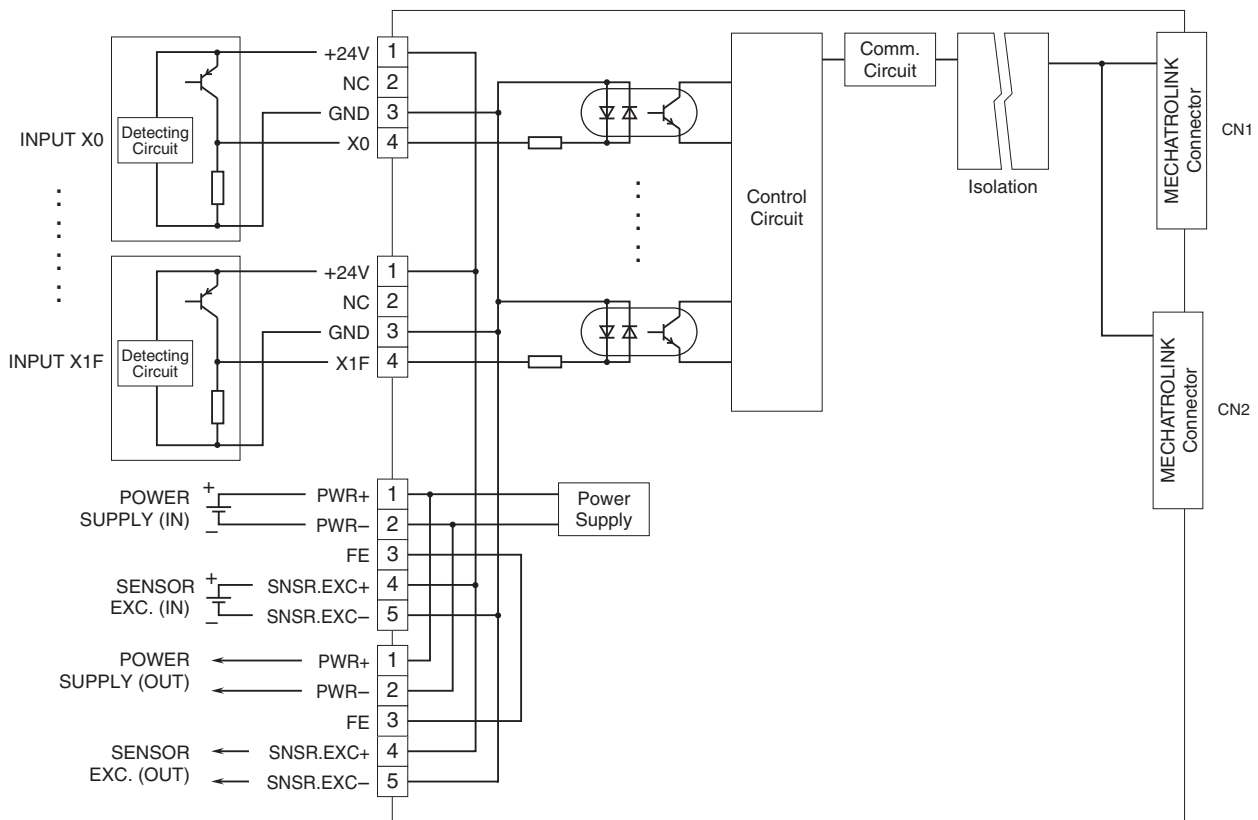

■ 2-Wire Sensor

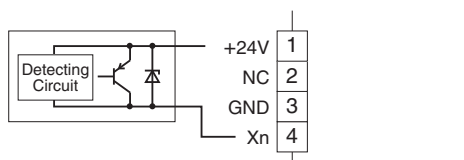

Specifications are subject to change without notice.