

Final Control Elements

SERVO-TOP II ELECTRONIC ACTUATOR

(linear type; max. thrust 5000 N)

Functions & Features

- Control valve actuator drive
- Lightweight, compact design
- High reliability without electrical contacts
- Friendly user interface
- High resolution stepping motor
- Failsafe (safety shutdown) function optional

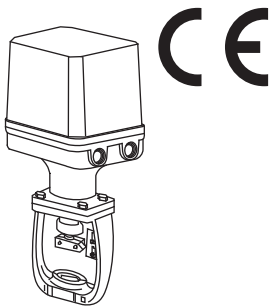

MODEL: PSN3-6[1][2]-[3][4][5]

ORDERING INFORMATION

- Code number: PSN3-6[1][2]-[3][4][5]

Specify a code from below for each of [1] through [5].
(e.g. PSN3-631-AK3/E)

- Use Ordering Information Sheet (No. ESU-4858). Default setting (table below) will be used if not otherwise specified.

PARAMETER	DEFAULT
Action	Reverse
Operation at abnormally low input	Stop
Output stem extended end	Longest
Output stem retracted end	Shortest
Ex-factory stem position	Shortest
Extended side limiter	0%
Retracted side limiter	100%
Full-open/-closed signal (extended)	2%
Full-open/-closed signal (retracted)	98%
Split range	Without
Split range type	LO
Split point	50%
Opening/closing speed	2.05 mm/s
Deadband	0.5%
Restart limiting timer	2 sec.
Failsafe target position *1	0%
Failsafe opening/closing speed *1	2.05 mm/s

*1. Option /E

STROKE

6: 0 to 60 mm (0 to 2.36")

[1] SEALING SPRING

- 1: 1500 N use
- 2: 3000 N use
- 3: 5000 N use

[2] OUTPUT STEM TYPE

- 1: M14 male screw, pitch 1.5
- 2: Stem button

[3] INPUT

Current

A: 4 - 20 mA DC (Input resistance 250 Ω)

Voltage

6: 1 - 5 V DC (Input resistance 1 MΩ min.)

[4] POWER INPUT

AC Power

K3: 100 - 120 V AC

(Operational voltage range 90 - 132 V, 47 - 66 Hz)
(CE not available)

L3: 200 - 240 V AC

(Operational voltage range 180 - 264 V, 47 - 66 Hz)

DC Power

R: 24 V DC

(Operational voltage range 24 V ±10 %, ripple 10 %p-p max.)

[5] OPTIONS

Failsafe Function (emergency use)

blank: Without

/E: With

RELATED PRODUCTS

- Manual operation handle (model: HPSN)
- Programming Unit (model: PU-2x)
- Backup battery (model: PSN-BAT)

GENERAL SPECIFICATIONS

Degree of protection: IP66
Action: Direct or reverse; field selectable with DIP switches
 In "reverse" action, the output stem is retracted with an input signal increase.
Operation at abnormally low input: Extend, retract or stop; field selectable with DIP switches
Detectable input drop level: 0.37 ±0.1 V DC; converted into voltage
Wiring conduits: G 1/2 female thread (two)
Terminal block: 7.62 mm pitch; M3 screw terminals (torque 0.5 N·m)
Screw terminal: Nickel-plated brass
Housing material: Aluminum alloy
Coating: Silver color
Drive: Stepping motor
Insulation class: E
Power control element: Power MOS-FET
Position detection: Brushless angle sensor
Full-open and full-closed positions: Any point within the full stroke; minimum stroke 8 % of the full stroke; field adjustable with control buttons
Full-open/-closed (extended) signal adj.: 0 - 25 %
Full-open/-closed (retracted) signal adj.: 75 - 100 %
Extended side limiter adjustment: -5 - +25 %
Retracted side limiter adjustment: 75 - 105 %
Deadband adjustment: 0.1 - 5.0 %
Restart limiting timer adjustment: 0 - 30 sec.
Opening/closing speed adjustment: 0.22 - 4.02 mm/s
Failsafe target position adjustment: 0 - 100 % (with failsafe function only)

Isolation

AC powered: Signal to power to sequential signal to battery status (with failsafe function only) to metallic housing

DC powered: Signal or power to sequential signal to battery status (with failsafe function only) to metallic housing

Fuse

AC powered: 3 A (replaceable)

DC powered: 4 A (replaceable)

Protective functions: Error detection, abnormal temperature increase protection, motor preheat

Power indicator: Green LED turns on with power supplied.

Input indicator: Green LED turns on with normal input

Alarm indicator: Red LED turns on in error; blinks in 1-sec. intervals when abnormal temperature increase is detected.

Manual operation: Available

Adjustments: Programming Unit (model: PU-2x); Full-open/full-closed positions, extended/retracted side limiters, full-open/full-closed signals, split range, opening/closing speed, deadband, restart limiting timer, failsafe

opening/closing speed (with failsafe function only), failsafe target position (with failsafe function only)

■ Battery (failsafe function option)

Battery chemistry: NiCad

Battery ambient temperature

Charge: 0 to 55°C (32 to 131°F)

Storage: -20 to +55°C (-4 to +131°F), short term
 -20 to +45°C (-4 to +113°F), long term

Battery life: Rechargeable up to 500 times; or 3 years, whichever is shorter, depending upon conditions of use

Drive capacity: Once

Charge method: Trickle charge after full rapid charge

Charge time: 180 minutes (completely discharged)

Battery status indicator LED: Turns on with full charge; turns off with the power removed.

Charge indicator LED: Turns on during rapid charge

INPUT SPECIFICATIONS

■ **DC Current:** Input resistor incorporated

• **Forced Operation:** External contact signal input terminals provided for compulsory retracting or extending operation

Rating: 5 V DC @ 2.5 mA

Detection levels:

≤ 500 Ω, ≤ 1 V for ON;

≥ 10 kΩ, ≥ 4 V for OFF

■ **Split Range:** Specify split range type and split point.

Split range type: LO or HI

Split point: 30 - 70 %

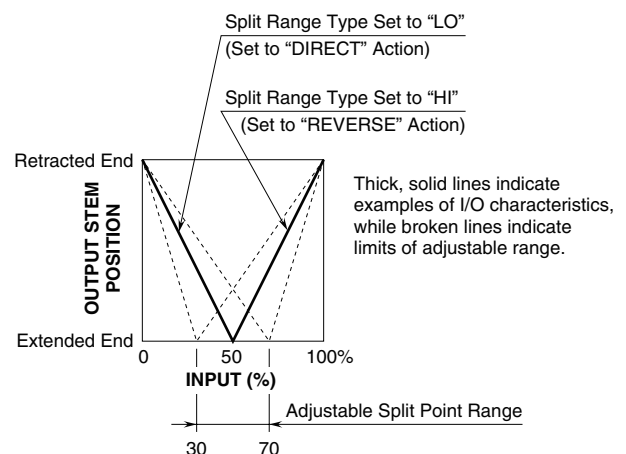

OUTPUT SPECIFICATIONS

■ **Position Signal:** 4 - 20 mA DC

Load resistance: ≤ 300 Ω

• **Sequential Control Signal:** "Full-open", "full-closed" and "alarm"

Open collector: 30 V DC @ 100 mA max.

Saturation voltage: 1 V DC

■ **Failsafe Function (optional)**

Battery status output: Outputs a signal in synchronization

with the battery status indicator; ON with full charge and OFF with the power removed.

Open collector: 30 V DC @ 100 mA

Saturation voltage: 1 V DC

■ Speed & Thrust

Acceleration or deceleration is not included in the speed. Acceleration or deceleration respectively requires approx. 0 to 2 sec.; takes longer with faster speed.

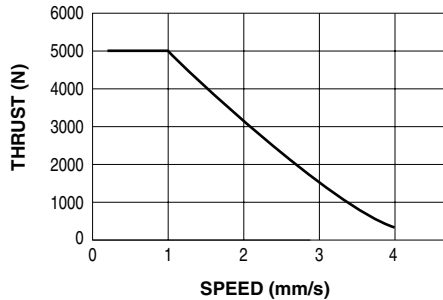

Sealing spring

TYPE	MAXIMUM PRESSURE (N)	FLEXURE AT MAXIMUM PRESS. (mm)	SET PRESS. (N)	RATED SPRING (N/mm)
1500 N use	1500	1	1170	330
3000 N use	3000	1	2410	590
5000 N use	5000	0.5	3980	2040
	(lbs)	(inch)	(lbs)	(lbs/in.)
1500 N use	337	0.04	263	1880
3000 N use	674	0.04	542	3370
5000 N use	1124	0.02	895	11600

INSTALLATION

Power consumption

- AC: Approx. 200 VA
- DC: Approx. 3 A

Operating temperature: -15 to +55°C (5 to 131°F)

Battery rechargeable within 0 to 55°C (32 to 131°F) with failsafe function

Operating humidity: 30 to 85 %RH (non-condensing)

Vibration: ≤ 2 G (19.6 m/s²)

Mounting position: All directions

Do not mount the actuator with its output stem on the upside if the actuator is to be exposed to dripping water and rain.

Weight: 8.9 kg (18.7 lb)

10.2 kg (22.5 lb) with failsafe function

PERFORMANCE

Resolution: 0.06 mm

Insulation resistance

AC powered: ≥ 100 MΩ with 500 V DC (signal to power to sequential signal to battery status (with failsafe function only) to metallic housing)

DC powered: ≥ 100 MΩ with 500 V DC

(signal or power to sequential signal to battery status (with failsafe function only) to metallic housing)

Dielectric strength

AC powered: 2000 V AC @ 1 minute

(signal or metallic housing to power to battery status (with failsafe function only) to sequential signal)
500 V AC @ 1 minute (signal to metallic housing)

DC powered: 2000 V AC @ 1 minute

(signal or power or metallic housing to battery status (with failsafe function only) to sequential signal)
500 V AC @ 1 minute (signal or power to metallic housing)

STANDARDS & APPROVALS

EU conformity:

EMC Directive

EMI EN 61000-6-4

EMS EN 61000-6-2

Low Voltage Directive

EN 61010-1

Installation Category II

Pollution Degree 2

Signal or metallic housing or seq. signals or battery status (with failsafe function only) to power:

Reinforced insulation (300 V)

RoHS Directive

EN 50581

TERMINOLOGY

• Error Detection

- When the position signal is deviated from the input signal but the output stem is stuck due to overload or certain malfunction, the PSN repeats starting the motor at the maximum torque for several items. If the stem is still stuck after that, the PSN outputs an alarm signal (LED turned ON) and stops power supply to the motor.

- In order to reset the PSN, apply several times 0 % and 100 % input signals in turn, or turn off and on the power supply.

• Abnormal Temperature Increase Protection

When the incorporated temperature sensor detects an abnormal temperature increase in the motor, the alarm LED blinks (repeating 0.5-sec. ON - 0.5-sec. OFF) and the power supply to the motor is stopped until the temperature decreases to an acceptable level. This electronic actuator is designed to resume automatically power supply to the motor. It takes longer to resume normal operation when ambient temperature is higher.

• Restart Limiting Timer

This unit is equipped with a timer protecting the motor from overheating. The timer prevents the motor from restarting for a certain interval once the motor has been stopped within deadband.

When the high temperature protection is activated in a high temperature ambient, adjust the timer to a longer interval.

- **Motor Preheat Function**

When this unit detects a temperature lower than 0°C or 32°F (approximate) on the surface of its motor, this unit supplies current to the motor in order to warm up and maintain its surface temperature at 5°C or 41°F (approximate).

Maintain the power supply ON when this unit is used in the ambient temperature below 0°C or 32°F.

- **Sealing Spring**

The PSN is incorporated with springs to maintain sealing pressure when the valve is fully closed. Choose an appropriate sealing pressure.

These springs provide the same pressure at both fully closed and fully open positions.

Do not apply a greater pressure to the spring than specified.

EXTERNAL DIMENSIONS unit: mm (inch)

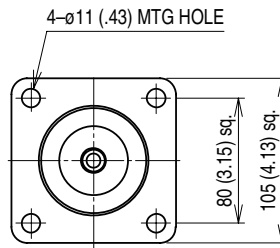
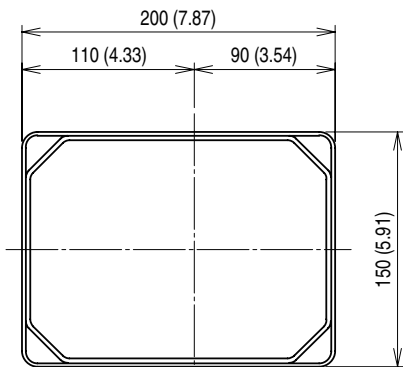

YOKE CONNECTION

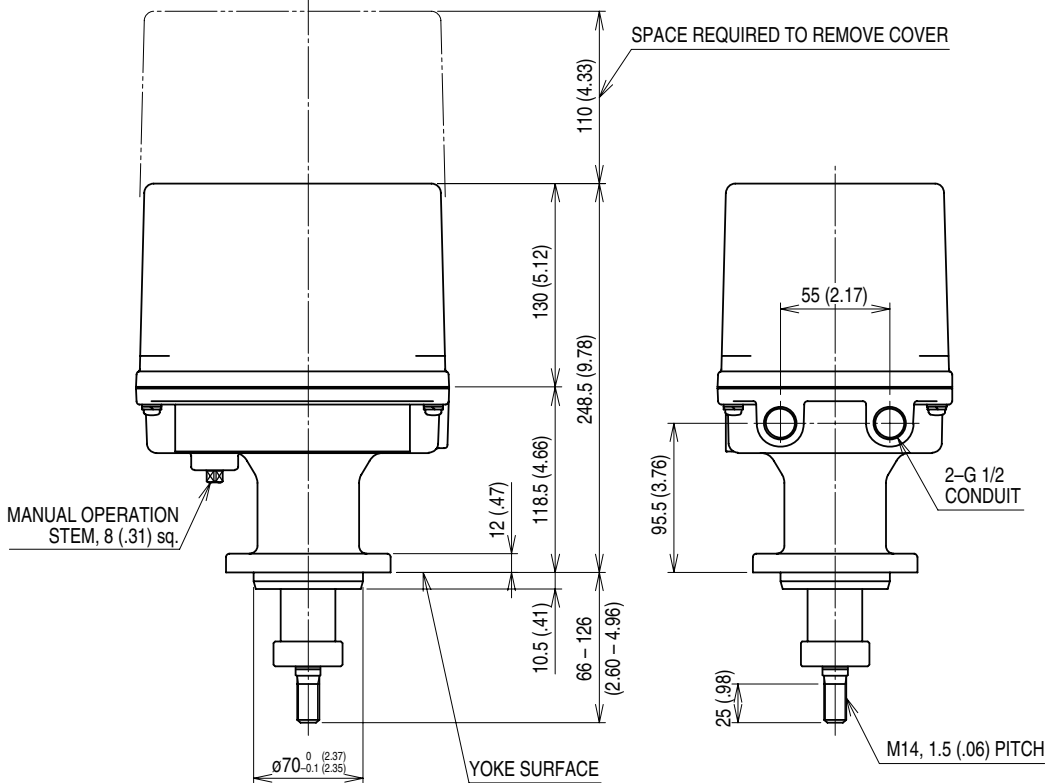

SPACE REQUIRED TO REMOVE COVER

MANUAL OPERATION STEM, 8 (.31) sq.

YOKE SURFACE

2-G 1/2 CONDUIT

M14, 1.5 (.06) PITCH

• Output Stem Detail with Stem Button Option

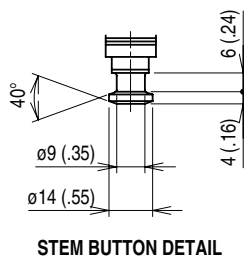
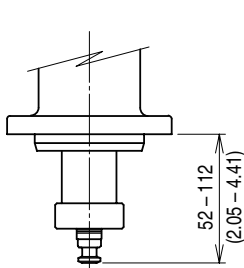

STEM BUTTON DETAIL

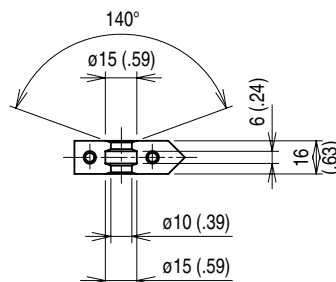
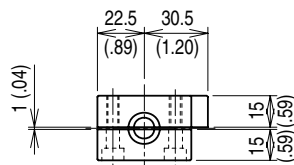

INDICATOR DETAIL

(accessory with the stem button option)

■ OPTION /E, FAILSAFE FUNCTION

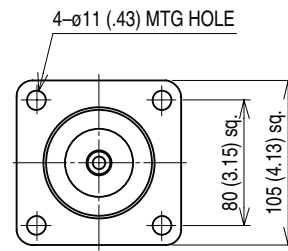
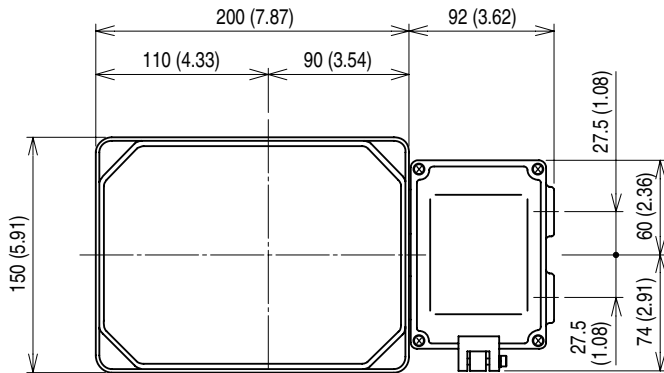

YOKE CONNECTION

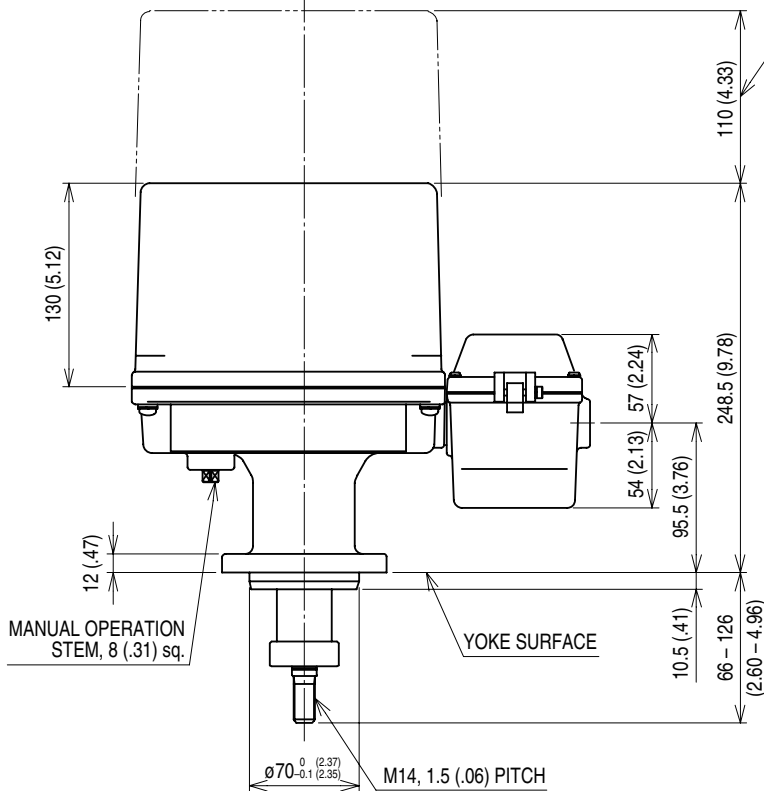

SPACE REQUIRED TO REMOVE COVER

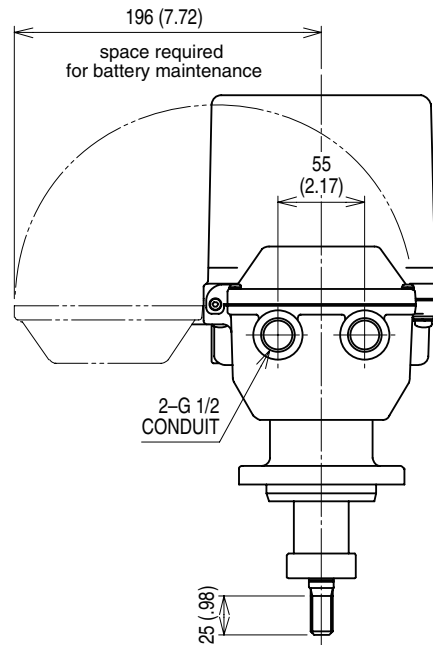

• Output Stem Detail with Stem Button Option

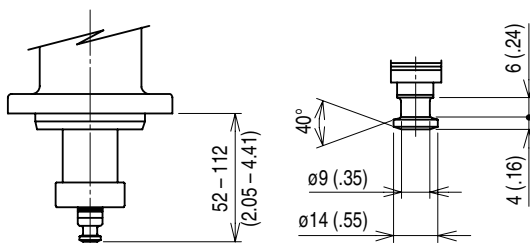

STEM BUTTON DETAIL

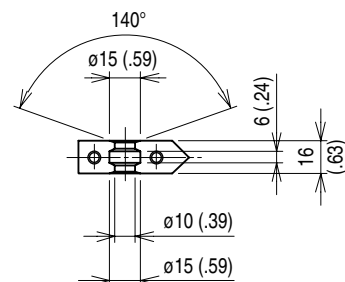
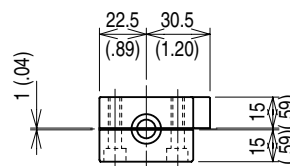

INDICATOR DETAIL

(accessory with the stem button option)

SCHEMATIC CIRCUITRY & CONNECTION DIAGRAM

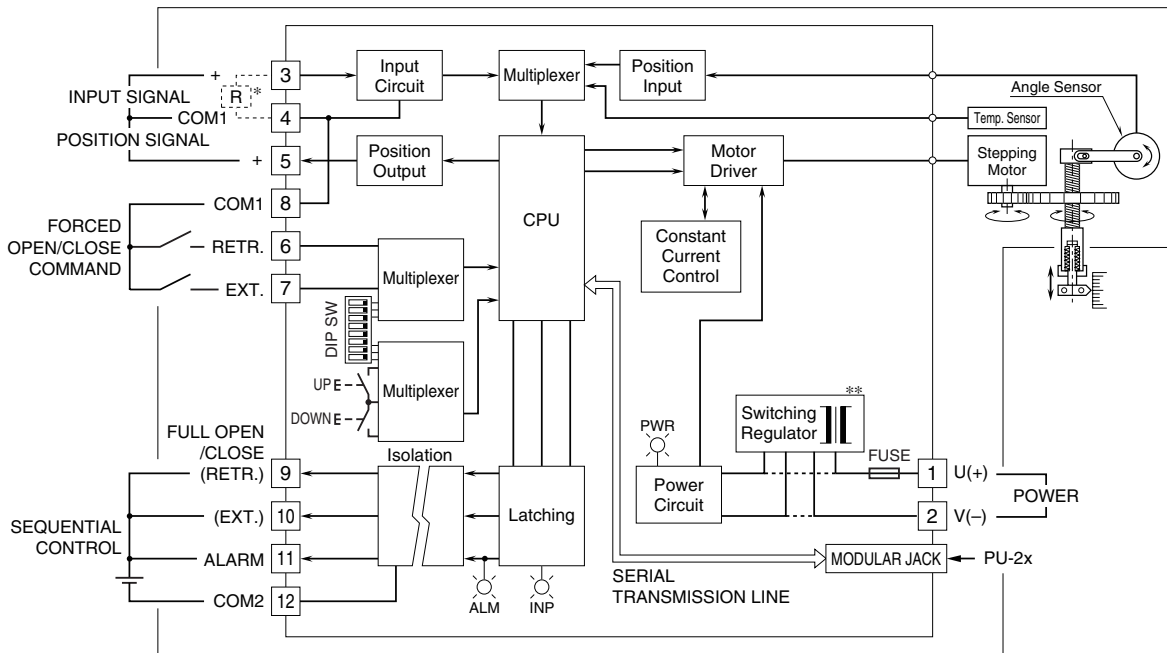

* Input resistor attached for a current input.
 **Switching regulator is not provided for DC power supply (shown in broken lines).

OPTION /E, FAILSAFE FUNCTION

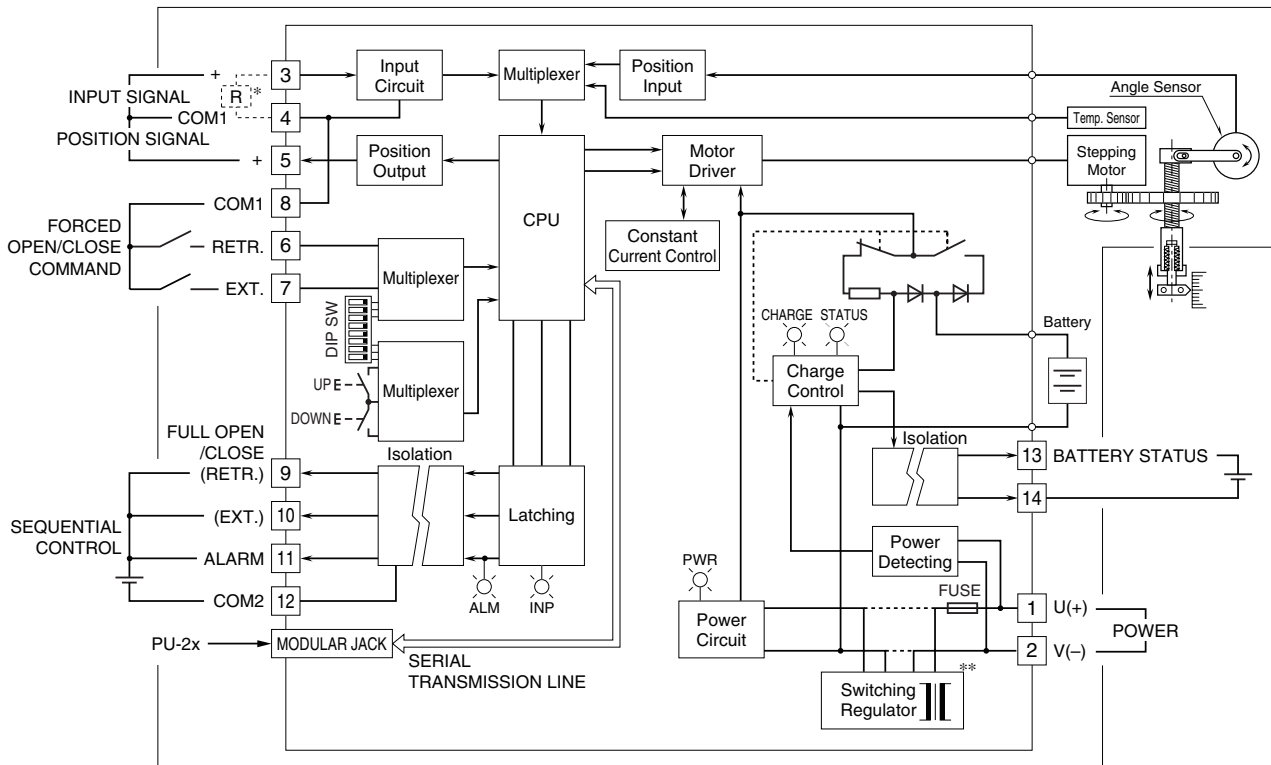

* Input resistor attached for a current input.
 **Switching regulator is not provided for DC power supply (shown in broken lines).

 Specifications are subject to change without notice.