

## Euro Terminal Ultra-Slim Signal Conditioners M6D Series

### RTD TRANSMITTER

(PC programmable)

#### Functions & Features

- 5.9-mm wide ultra-slim design
- Low profile allows the M6D module mounted in a 120-mm deep panel
- Accepts direct input from an RTD and provides an isolated, linearized DC signal
- Linearization and burnout protection
- PC programmable
- High-density mounting
- Power indicator LED

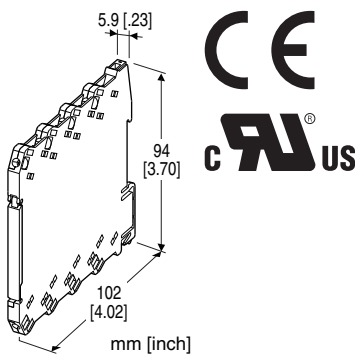

### MODEL: M6DXR-[1][2]-R[3]

#### ORDERING INFORMATION

- Code number: M6DXR-[1][2]-R[3]
- Specify a code from below for each of [1] through [3].  
(e.g. M6DXR-4Z1-R/UL/Q)
- Temperature range (e.g. 0 - 100°C)
- Output range (e.g. 4 - 20 mA DC)
- Specify the specification for option code /Q  
(e.g. /C01/SET)

#### [1] INPUT RTD

**1:** JPt 100 (JIS'89)

(Usable range: -200 to +500°C, -328 to +932°F; min.span: 20°C, 36°F)

**3:** Pt 100 (JIS'89)

(Usable range: -200 to +650°C, -328 to +1202°F; min.span: 20°C, 36°F)

**4:** Pt 100 (JIS'97, IEC)

(Usable range: -200 to +850°C, -328 to +1562°F; min.span: 20°C, 36°F)

**5:** Pt 50 Ω (JIS'81)

(Usable range: -200 to +649°C, -328 to +1200°F; min.span: 20°C, 36°F)

**7:** Pt 1000

(Usable range: -200 to +850°C, -328 to +1562°F; min.span: 20°C, 36°F)

**9:** Cu 10 @25°C

(Usable range: -50 to +250°C, -58 to +482°F; min.span: 20°C, 36°F)

**0:** Specify (Please provide a resistance table.)

(Configurator software is used to change the input type and range.

Input code 7, 0 cannot be switched to/from other input types while its temperature range can be changed. It is not available to switch from input code 1, 3, 4, 5, and 9 to '7' or '0'. Be aware above.)

#### [2] OUTPUT

##### Current

**Z1:** Range 0 - 20 mA DC

##### Voltage

**V2:** Range -10 - +10 V DC

**V3:** Range -5 - +5 V DC

(Configurator software is used to change output over the described range of the selected suffix code.

For changing between suffix codes, set the Output Range Selector on the side of unit before software adjustment.)

#### POWER INPUT

##### DC Power

**R:** 24 V DC

(Operational voltage range 24 V ±10 %, ripple 10 %p-p max.)

#### [3] OPTIONS (multiple selections)

##### Standards & Approvals

**blank:** CE marking

**/UL:** UL approval, CE marking

##### Other Options

**blank:** none

**/Q:** Option other than the above (specify the specification)

#### SPECIFICATIONS OF OPTION: Q (multiple selections)

##### COATING (For the detail, refer to M-System's web site.)

**/C01:** Silicone coating

**/C02:** Polyurethane coating

##### EX-FACTORY SETTING

**/SET:** Preset according to the Ordering Information Sheet  
(No. ESU-7833)

#### RELATED PRODUCTS

- PC configurator software (model: M6CFG)

Downloadable at M-System's web site.

A dedicated cable is required to connect the module to the PC. Please refer to the internet software download site or the users manual for the PC configurator for applicable cable types.

## GENERAL SPECIFICATIONS

### Connection

**Input and output:** Euro terminal (torque 0.3 N·m)  
**Power input:** Via the Installation Base (model: M6DBS) or Euro terminal (torque 0.3 N·m)  
**Applicable wire size:** 0.2 to 2.5 mm<sup>2</sup>, stripped length 8 mm  
**Housing material:** Flame-resistant resin (black)  
**Isolation:** Input to output to power  
**Overrange output:** -2 - +102 %  
 (Negative current output is not available.)  
**Zero adjustment:** -2 to +2 % (PC programming)  
**Span adjustment:** 98 to 102 % (PC programming)  
**Burnout:** Upscale standard; downscale or no burnout optional by programming  
**Linearization:** Standard  
**Power indicator LED:** Green LED turns on when the power is supplied.

**Status indicator LED:** Orange LED; Blinking patterns indicate different operating status of the transmitter.

**Programming:** Downloaded from PC; input type and range, output type and range, zero and span, burnout type, user's linearization table, sensor wires, temperature unit, response characteristics (version 1.30 or later), filter time constant, etc.

For detailed information on the For detailed information, refer to the users manual for the PC configurator.

**Configurator connection:** 2.5 dia. miniature jack; RS-232-C level

## INPUT SPECIFICATIONS

**Input:** 2-, 3- or 4-wire RTD  
**Maximum leadwire resistance:** 10 Ω per wire  
**Sensing current;** ≤ 1.5 mA  
 (≤ 0.15 mA for input code 7: Pt 1000 or code 0  
 Specified maximum resistance in the table > 500 Ω)  
**Resistance range:**  
 0 - 500 Ω (Input code: 1, 3, 4, 5, 9)  
 0 - 5 kΩ (Input code: 7)  
 If not specified, the input range is 0 - 100°C.

## OUTPUT SPECIFICATIONS

### ■ DC Current

**Output range:** 0 - 20 mA DC  
**Conformance range:** 0 - 20.4 mA DC  
**Minimum span:** 1 mA  
**Offset:** Lower range can be any specific value within the output range provided that the minimum span is maintained.  
**Load resistance:** Output drive 11 V max.  
 (e.g. 4 - 20 mA: 550 Ω [11 V ÷ 20 mA])  
 If not specified, the output range is 4 - 20 mA DC.

### ■ DC Voltage

**Code V2 (wide spans)**  
**Output range:** -10 - +10 V DC  
**Conformance range:** -10.4 - +10.4 V DC  
**Minimum span:** 1 V  
**Code V3 (narrow spans)**  
**Output range:** -5 - +5 V DC  
**Conformance range:** -5.2 - +5.2 V DC  
**Minimum span:** 0.5 V  
**Offset:** Lower range can be any specific value within the output range provided that the minimum span is maintained.  
**Load resistance:** Output drive 1 mA max.  
 (e.g. 1 - 5 V: 5000 Ω [5 V ÷ 1 mA])  
 If not specified, the output range is shown below.  
 V2: 0 - 10 V DC  
 V3: 1 - 5 V DC

## INSTALLATION

**Power consumption:** Approx. 0.5 W  
**Operating temperature:** -20 to +55°C (-4 to +131°F)  
**Operating humidity:** 30 to 90 %RH (non-condensing)  
**Mounting:** Installation Base (model: M6DBS) or DIN rail  
**Weight:** 65 g (2.3 oz)

## PERFORMANCE in percentage of span

**Overall accuracy:** Input accuracy + output accuracy  
 Inversely proportional to the span.  
 See CALCULATION EXAMPLES OF OVERALL ACURACY.  
 • **Input accuracy:** (whichever is greater)  
 ±0.1 % of input range or ±0.15°C (Pt and JPt)  
 ±0.1 % of input range or ±1°C (Cu 10)  
 • **Output accuracy:** ±0.04 % of max. output range  
**Temp. coefficient:** ±0.01 %/°C (±0.006 %/°F) of max. span  
**Response time:** ≤ 1 sec. (0 - 90 %)  
**Burnout response:** ≤ 10 sec.  
**Line voltage effect:** ±0.1 % over voltage range  
**Insulation resistance:** ≥ 100 MΩ with 500 V DC  
**Dielectric strength:** 2000 V AC @1 minute (input to output to power to ground)

## CALCULATION EXAMPLES OF OVERALL ACCURACY

[Example] Pt 100, 0 - 100°C, Output Type -5 - +5V, Output Range 1 - 5V  
 Input Accuracy\*\* (0.15°C\*\*\*) ÷ Span (100°C) × 100 %  
 + Max. Output Range (10V) ÷ Span (4V) × 0.04 %  
 = ±0.25 %  
 \*\*Calculate the accuracy in °C.  
 \*\*\*100°C × 0.1 % = 0.1°C ≤ 0.15°C. 0.15°C is used as input accuracy value.

## STANDARDS & APPROVALS

### EU conformity:

EMC Directive

EMI EN 61000-6-4

EMS EN 61000-6-2

RoHS Directive

### Approval:

UL/C-UL nonincendive Class I, Division 2,

Groups A, B, C, and D

(ANSI/ISA-12.12.01, CAN/CSA-C22.2 No.213)

UL/C-UL general safety requirements

(UL 61010-1, CAN/CSA-C22.2 No.61010-1)

## EXTERNAL VIEW

FRONT VIEW (with the cover open)

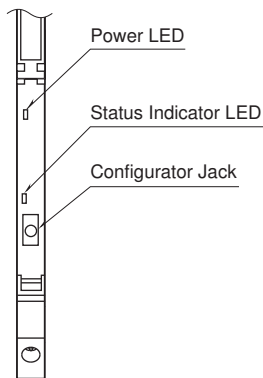

SIDE VIEW

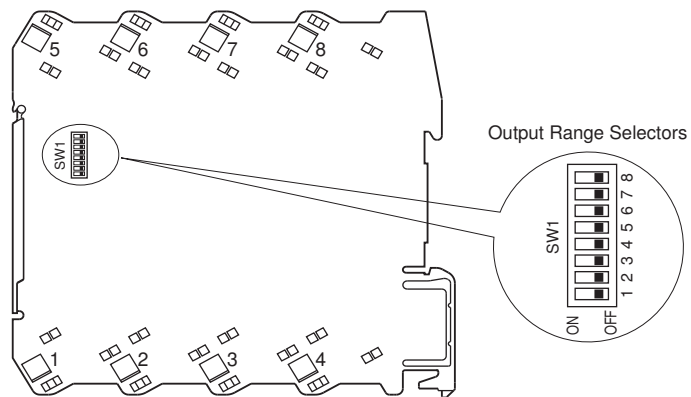

The DIP switch setting is required to select output types before setting a precise output range using PC Configurator Software (model: M6CFG).

Refer to the instruction manual for detailed procedures.

## EXTERNAL DIMENSIONS & TERMINAL ASSIGNMENTS unit: mm [inch]

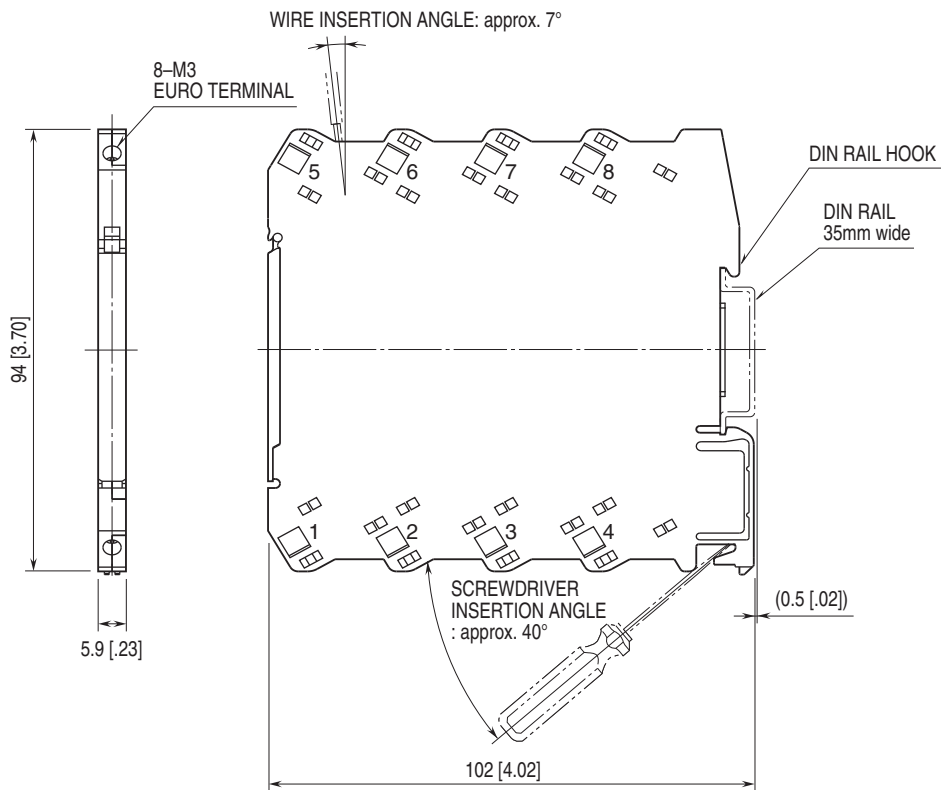

• When mounting, no extra space is needed between units.

## SCHEMATIC CIRCUITRY & CONNECTION DIAGRAM

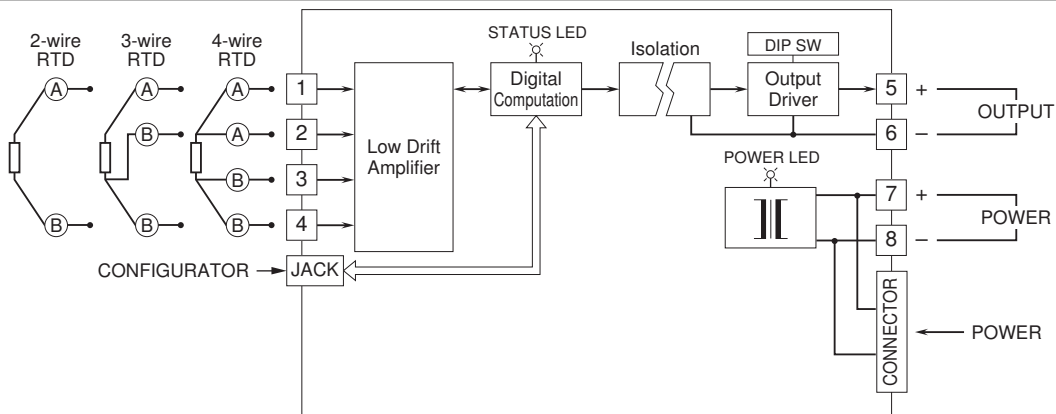

Specifications are subject to change without notice.