

## Euro Terminal Ultra-Slim Signal Conditioners M6D Series

### CT TRANSMITTER

(clamp-on current sensor)

#### Functions & Features

- Converts AC current signal into a low-ripple standard process signal suitable to be handled for computer inputs
- 5.9-mm wide ultra-slim design
- Low profile allows the M6D module mounted in a 120-mm deep panel
- High-density mounting
- Power indicator LED

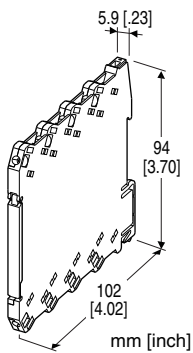

### MODEL: M6DCTC-[1][2]-R[3]

#### ORDERING INFORMATION

- Code number: M6DCTC-[1][2]-R[3]

Specify a code from below for each of [1] through [3].

- (e.g. M6DCTC-56004W-R/Q)
- Special output range (For codes Z & 0)
- Specify the specification for option code /Q (e.g. /C01)

Order Clamp-on current sensor separately.

#### [1] INPUT

##### Sensor CLSE

- 5R5: 0 - 5 A AC
- 550: 0 - 50 A AC
- 5100: 0 - 100 A AC
- 5200: 0 - 200 A AC
- 5400: 0 - 400 A AC
- 5600: 0 - 600 A AC

##### Sensor CLSB (CE not available)

- 210: 0 - 10 A AC
- 215: 0 - 15 A AC
- 220: 0 - 20 A AC
- 230: 0 - 30 A AC
- 240: 0 - 40 A AC
- 250: 0 - 50 A AC

- 260: 0 - 60 A AC
- 275: 0 - 75 A AC
- 2100: 0 - 100 A AC
- 2125: 0 - 125 A AC
- 2150: 0 - 150 A AC
- 2175: 0 - 175 A AC
- 2200: 0 - 200 A AC
- 2225: 0 - 225 A AC
- 2250: 0 - 250 A AC
- 2300: 0 - 300 A AC
- 2350: 0 - 350 A AC
- 2400: 0 - 400 A AC
- 2500: 0 - 500 A AC
- 2600: 0 - 600 A AC

#### [2] OUTPUT

##### Current

- A: 4 - 20 mA DC (Load resistance 550 Ω max.)
- D: 0 - 20 mA DC (Load resistance 550 Ω max.)
- G: 0 - 1 mA DC (Load resistance 11 kΩ max.)
- Z: Specify current (See OUTPUT SPECIFICATIONS)

##### Voltage

- 3: 0 - 1 V DC (Load resistance 1000 Ω min.)
- 4: 0 - 10 V DC (Load resistance 10 kΩ min.)
- 5: 0 - 5 V DC (Load resistance 5000 Ω min.)
- 6: 1 - 5 V DC (Load resistance 5000 Ω min.)
- 4W: -10 - +10 V DC (Load resistance 20 kΩ min.)
- 5W: -5 - +5 V DC (Load resistance 10 kΩ min.)
- 0: Specify voltage (See OUTPUT SPECIFICATIONS)

#### POWER INPUT

##### DC Power

- R: 24 V DC
- (Operational voltage range 24 V ±10 %, ripple 10 %p-p max.)

#### [3] OPTIONS

- blank: none
- /Q: With options (specify the specification)

#### SPECIFICATIONS OF OPTION: Q

##### COATING (For the detail, refer to M-System's web site.)

- /C01: Silicone coating
- /C02: Polyurethane coating

#### RELATED PRODUCTS

- Clamp-on current sensor (model: CLSB)
- Clamp-on current sensor (model: CLSE)
- (Select "CLSE-x/CE" to comply with CE for the combination with the sensor.)

## GENERAL SPECIFICATIONS

### Connection

**Input and output:** Euro terminal (torque 0.3 N·m)

**Power input:** Via the Installation Base (model: M6DBS)  
or Euro terminal (torque 0.3 N·m)

**Applicable wire size:** 0.2 to 2.5 mm<sup>2</sup>, stripped length 8 mm

**Housing material:** Flame-resistant resin (black)

**Isolation:** Input to output to power

### Input waveform

**RMS sensing:** Up to 15 % of 3rd harmonic content

**Zero adjustment:** -2 to +2 % (front)

(Output code 4W, 5W: Adjustable at 0V. No output below 0 mA for the code D.)

**Span adjustment:** 98 to 102 % (front)

**Power indicator LED:** Green LED turns on when the power is supplied.

## INPUT SPECIFICATIONS

### ■ Clamp-on current sensor CLSE

(Sensor model No.: AC input)

**CLSE-R5:** 0 - 5 A

**CLSE-05:** 0 - 50 A

**CLSE-10:** 0 - 100 A

**CLSE-20:** 0 - 200 A

**CLSE-40:** 0 - 400 A

**CLSE-60:** 0 - 600 A

**Frequency:** 50 / 60 Hz

**Operational range:** 5 - 120 % of rating

### Overload capacity:

**CLSE-R5:** 10 A continuous

**CLSE-05:** 60 A continuous

**CLSE-10:** 120 A continuous

**CLSE-20:** 240 A continuous

**CLSE-40:** 480 A continuous

**CLSE-60:** 720 A continuous

Be sure that the input voltage is of 480 V or less.

### ■ Clamp-on current sensor CLSB

(Sensor model No.: AC input)

#### CLSB-05:

0 - 10 A, 0 - 15 A, 0 - 20 A

0 - 30 A, 0 - 40 A, 0 - 50 A

#### CLSB-10:

0 - 60 A, 0 - 75 A, 0 - 100 A

#### CLSB-20:

0 - 125 A, 0 - 150 A, 0 - 175 A

0 - 200 A, 0 - 225 A, 0 - 250 A

#### CLSB-40:

0 - 300 A, 0 - 350 A, 0 - 400 A

#### CLSB-60:

0 - 500 A, 0 - 600 A

**Frequency:** 50 / 60 Hz

**Operational range:** 5 - 120 % of rating

### Overload capacity:

**CLSB-05:** 100 A continuous

**CLSB-10:** 200 A continuous

**CLSB-20:** 300 A continuous

**CLSB-40:** 600 A continuous

**CLSB-60:** 720 A continuous

Be sure that the input voltage is of 440 V or less.

## OUTPUT SPECIFICATIONS

■ **DC Current:** 0 - 20 mA DC

**Minimum span:** 1 mA

**Offset:** Max. 1.5 times span

**Load resistance:** Output drive 11 V max.

■ **DC Voltage:** 0 - 10 V DC

**Minimum span:** 1 V

**Offset:** Max. 1.5 times span

**Load resistance:** Output drive 1 mA max.; at  $\geq 1$  V

## INSTALLATION

**Power consumption:** Approx. 0.5 W

**Operating temperature:** -20 to +55°C (-4 to +131°F)

**Operating humidity:** 30 to 90 %RH (non-condensing)

**Mounting:** Installation Base (model: M6DBS) or DIN rail

**Weight:** 60 g (2.1 oz)

## PERFORMANCE in percentage of span

**Accuracy:**  $\pm 0.5$  % with input 5 - 100 %

**Temp. coefficient:**  $\pm 0.015$  %/°C ( $\pm 0.008$  %/°F)

**Response time:**  $\leq 1$  sec. (0 - 90 %)

**Line voltage effect:**  $\pm 0.1$  % over voltage range

**Insulation resistance:**  $\geq 100$  M $\Omega$  with 500 V DC

**Dielectric strength:** 2000 V AC @1 minute (input to output to power to ground)

## STANDARDS & APPROVALS

### EU conformity:

EMC Directive

EMI EN 61000-6-4

EMS EN 61000-6-2

RoHS Directive

## EXTERNAL VIEW

(With the cover open)

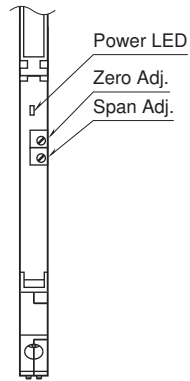

## EXTERNAL DIMENSIONS & TERMINAL ASSIGNMENTS unit: mm [inch]

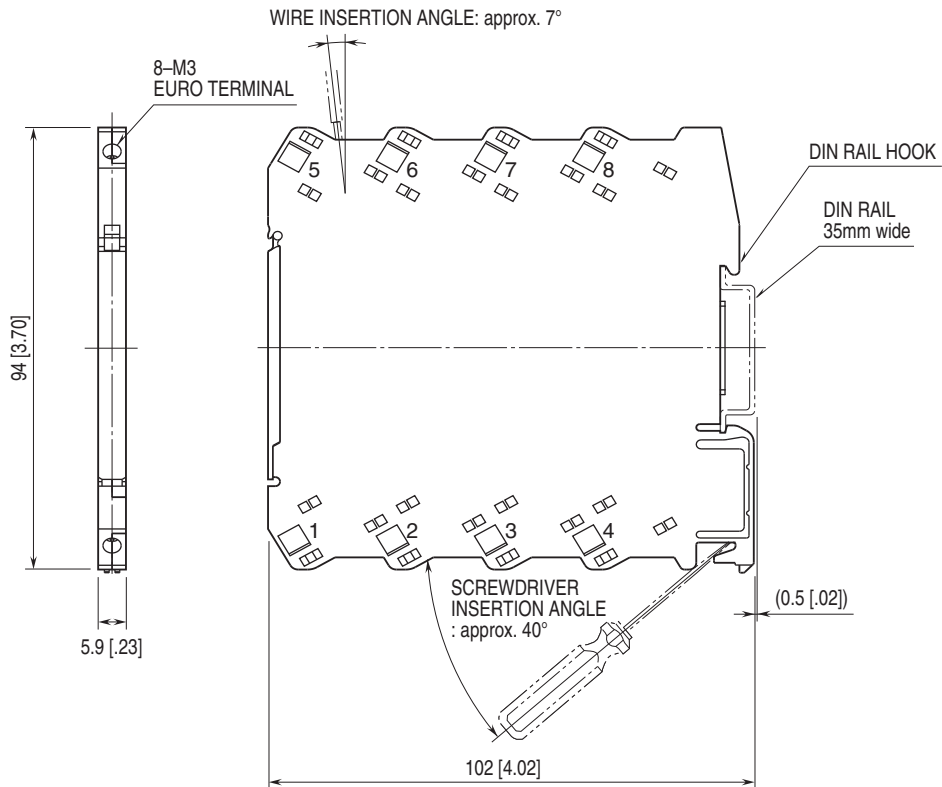

• When mounting, no extra space is needed between units.

**SCHEMATIC CIRCUITRY & CONNECTION DIAGRAM**

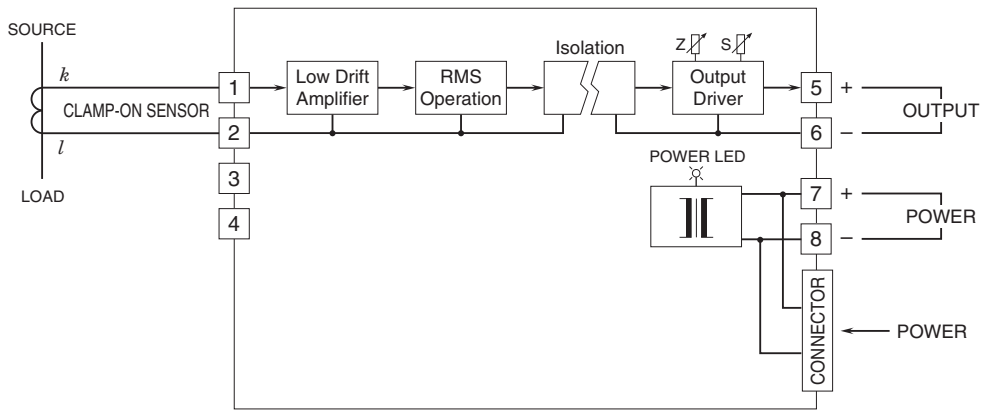

Specifications are subject to change without notice.