

## Final Control Elements

### MINI-TOP ELECTRONIC ACTUATOR

(linear type; DeviceNet)

#### Functions & Features

- Small-size control valve actuator
- Direct connection to DeviceNet capable PLC and other devices on the same network
- Easy wired
- Remote configuration via DeviceNet
- Uploading device information via DeviceNet for maintenance purpose
- 1/1000 high resolution

#### Typical Applications

- Small-diameter control valve used in food related plants or in co-generation systems
- Air-conditioning in buildings or plants
- Micro-flow control for pharmaceutical injection

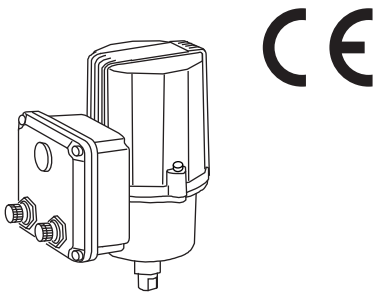

### MODEL: MSP4D-[1][2][3]-[4]R

#### ORDERING INFORMATION

- Code number: MSP4D-[1][2][3]-[4]R
- Specify a code from below for each of [1] through [4].  
(e.g. MSP4D-271-CR)

#### [1] STROKE

- 1: 5 to 10 mm (.20" to .39")  
2: 8 to 15 mm (.31" to .59")

#### [2] OPERATION TIME, THRUST

- 6: 24 sec. / 10 mm, 500 N  
7: 30 sec. / 10 mm, 700 N

#### [3] OUTPUT STEM TYPE

- 6: M6 female thread, 0.75 pitch  
8: M8 female thread, 1.0 pitch  
1: M10 female thread, 1.25 pitch

- D: M6 female thread, 1.0 pitch  
E: M8 female thread, 1.25 pitch  
F: M10 female thread, 1.5 pitch

#### [4] CE MARKING

- C: With  
0: Without

#### POWER INPUT

##### DC Power

R: 24 V DC

(Operational voltage range 24 V  $\pm$ 10 %, ripple 10 %p-p max.)

#### GENERAL SPECIFICATIONS

**Degree of protection:** IP66 (IP67 connector)

**Action:** Direct or reverse (factory set to "reverse")

(In "reverse" action, the output stem is retracted with an input signal increase.)

**Operation at a communication error:** Extend, retract or stop (DIP SW selectable; factory set to "stop")

**Node address:** 0 - 63; DIP SW selectable

**Baud rate:** 125 k, 250 k, 500 k bps (DIP SW selectable; factory set to 125 kbps)

##### Circuit connection

**Communication:** 5-core microconnector, male

**Power:** 4-core microconnector, male

**Transmission cable:** Approved for DeviceNet (e.g. OMRON DCA1)

**Power input cable:** With connector (e.g. OMRON XS2F or XS2WD42)

**Housing material:** Cast aluminum

**Drive:** Stepping motor

**Insulation class:** E

**Position detection:** Potentiometer

**Isolation:** Communication to power

**Zero adjustment:** 0 - 25 %

**Span adjustment:** 50 - 100 %

**MS (Module Status) indicator:** Bi-color (green/red) LED indicates device status.

**NS (Network Status) indicator:** Bi-color (green/red) LED indicates status of the communication link.

**Manual operating handle:** Not available

#### OUTPUT SPECIFICATIONS

■ **Operation Time & Torque** (at rated power voltage)

MSP4D-x6: 24 seconds / 10 mm, 500 N (112 lbf)

MSP4D-x7: 30 seconds / 10 mm, 700 N (157 lbf)

## INSTALLATION

### Current consumption

•DC: Approx. 0.5 A

**Supply voltage to network:** 11 - 25 V DC supplied through the network terminal block

**Supply current to network:** 60 mA max.

**Operating temperature:** -5 to +55°C (23 to 131°F)

**Operating humidity:** 30 to 85 %RH (non-condensing)

**Vibration:** 0.5 G (4.9 m/s<sup>2</sup>) max.

**Mounting position:** All directions

Do not mount the actuator with its output stem or cable connector on the upside if the actuator is to be exposed to dripping water.

**Weight:** 1.5 kg (3.3 lb)

## PERFORMANCE

**Resolution:** 1/1000 or 0.015 mm, whichever is greater, with 0.1 % deadband setting

### Insulation resistance:

≥ 100 MΩ with 500 V DC (communication [except drain] to power or metallic housing)

≥ 100 MΩ with 100 V DC (power to metallic housing)

### Dielectric strength:

1500 V AC @ 1 minute (communication [except drain] to power or metallic housing)

100 V AC @ 1 minute (power to metallic housing)

## STANDARDS & APPROVALS

### EU conformity:

EMC Directive

EMI EN 61000-6-4

EMS EN 61000-6-2

RoHS Directive

EN 50581

## COMMUNICATIONS

ITEM	ACCESS	FUNCTION	RANGE
Remote/Local	Get	Confirm Communication/Manual SW Setting Shows the switch position on the control circuit board of the actuator. No control over the communications network available when the switch is set to Manual.	0 : Remote (communication) 1 : Local (manual)
RunEnable	Set / Get	Start Running "Input as Target," "ForcedRetracting" and "ForcedExtending" enabled when this signal is set to "1."	0 : Stop 1 : Start
Input as Target	Set / Get	Target Position Input The set value equal to the output stem position setpoint if no scaling is performed. The setting is overridden if "ForcedRetracting" or "ForcedExtending" is ON.	Range: -50 to 10050 ( $\times 0.01\%$ ); 0.1% resolution; lesser digits are disregarded.
Present Position	Get	Position Output 0% = Extended; 100% = Retracted These relations do not change by "Direction" setting.	Range: -50 to 10050 ( $\times 0.01\%$ )
Allowable DEVN	Get	Position Achieved "1" is output when the output stem is inside the deadband.	0 : Out of deadband 1 : Stable within deadband
DeadBand	Set / Get	Set Deadband Deadband is adjustable from 0.1 to 9.9%, in 0.2% increments such as 0.1, 0.3, 0.5, ... 9.7 and 9.9%. Fractions are dropped.	Range: 10 to 1000 Default: 50 ( $\times 0.01\%$ )
RestartLMTG TMR	Set / Get	Restart Limiting Timer The output stem does not restart before the set time once it is stopped.	Range: 0 to 255 Default: 0 ( $\times 0.1$ sec.)
Forced Retracting	Set	Forced Positioning Input Output stem forced to the position specified with "ForcedRETR End." "Input as Target" setting is overridden.	0 : OFF 1 : ON Default: 0
Forced Extending	Set	Forced Positioning Input Output stem forced to the position specified with "ForcedEXTND End." "Input as Target" setting is overridden.	0 : OFF 1 : ON Default: 0
ForcedRETR End	Set / Get	Set Forced Position The targeted output stem position when "ForcedRetracting" is ON.	Range: 0 to 10050 Default: 10000 ( $\times 0.01\%$ )
ForcedEXTND End	Set / Get	Set Forced Position The targeted output stem position when "ForcedExtending" is ON.	Range: -50 to 10000 Default: 0 ( $\times 0.01\%$ )
Signal at RETR	Get	Full Open / Close Signal ON when the stem position is over "RETR SIG POSN" setting.	0 : OFF 1 : ON
Signal at EXTND	Get	Full Open / Close Signal ON when the stem position is below "EXTND SIG POSN" setting.	0 : OFF 1 : ON
RETR SIG POSN	Set / Get	Set Full Open / Close Position "Signal at RETR" turns ON when the stem position is over this setting.	Range: 0 to 10050 Default: 9800 ( $\times 0.01\%$ )
EXTND SIG POSN	Set / Get	Set Full Open / Close Position "Signal at EXTND" turns ON when the stem position is below this setting.	Range: -50 to 10000 Default: 200 ( $\times 0.01\%$ )
Error	Get	Confirm Error One or more items among "Motor Deadlock," "Illegal Input" and "Memory Fault" are true.	0 : Normal 1 : Error
Motor Deadlock	Get	Motor Deadlock Error The actuator stops power supply to the motor if the motor cannot be restarted after it tries to for the number of preset "Retry" times in series. Reset by "ClearDeadlockSIG."	0 : Normal 1 : Error
Illegal Input	Get	Illegal Target Position Input The target position set to a value out of the range from -50 to 10050.	0 : Normal 1 : Error
Memory Fault	Get	Memory Fault The memory on the actuator control circuit board is in error. The actuator operation is disabled.	0 : Normal 1 : Error
ClearDeadlockSIG	Set	Clear Deadlock Signal Reset "Motor Deadlock." Return the signal to "0" after this operation, otherwise "Motor Deadlock" remains disabled and the actuator retries to drive the motor until the cause of deadlock is removed.	0 : Disabled 1 : Clear Default: 0

ITEM	ACCESS	FUNCTION	RANGE
Retry	Set / Get	Set Retry Times The actuator tries to restart for the number of preset "Retry" times.	Range: 1 to 255 Default: 5
IllegalInputOPN	Set / Get	Illegal Input Operation Set the actuator's operation in case of an illegal input.	0 : Input limit position 1 : Stop 2 : 0% position 3 : 100% position Default: 0
COMM ErrorOPN	Get	Confirm Communication Error Operation Setting Shows the communication error operation setting on the control circuit board of the actuator.	0 : Stop 1 : 0% position 2 : 100% position
COMM FaultTime	Set / Get	Set Stand-by Time Before Starting Communication Error Operation The time to wait in case of a communication error before starting the pre-designated operation.	Range: 10 to 255 Default: 10 (sec.)
Direction	Set / Get	Set Input Action Direct action: 100% output at 0% input Reverse action: 0% output at 0% input Not related to relations between Present Position (position output) and actual stem position.	0 : Reverse 1 : Direct Default: 0
MIN input	Set / Get	Position Target Input Limit Set the lower limit of "Input as Target." Any input below the setpoint is clamped to the set value.	Range: -50 to 10000 Default: -50 (×0.01%)
MAX input	Set / Get	Position Target Input Limit Set the upper limit of "Input as Target." Any input above the setpoint is clamped to the set value.	Range: 0 to 10050 Default: 10050 (×0.01%)
Input as Zero	Set / Get	Input Scaling (such as for Split Control) "Input as Target" value for 0% output stem position setpoint.	Range: -50 to 10000 Default: 0 (×0.01%)
Input as Full	Set / Get	Input Scaling (such as for Split Control) "Input as Target" value for 100% output stem position setpoint.	Range: 0 to 10050 Default: 10000 (×0.01%)
DeadlockCNTR	Set / Get	Deadlock Counter Shows the totalized number of Retries at a deadlock.	Range: 0 to 65535 (×1)
LastDeadlockPOSN	Get	Confirm Motor Deadlock Position Shows the output stem position at the last deadlock.	Range: -50 to 10050 (×0.01%) Default: 32767 (invalid data)
StartingCNTR * <sup>1</sup>	Set / Get	Motor Starting Counter Shows the totalized number of starting the motor.	Range: 0 to 4294967295 (×1)
TurnOverCNTR * <sup>1</sup>	Set / Get	Motor Reversing Counter Shows the totalized number of reversing the motor direction.	Range: 0 to 4294967295 (×1)
Accumulated MVT * *	Set / Get	Accumulated Running Distance Shows the accumulated running distance. 100% span defined with Zero and Span adjustments on the PCB.	Range: 0 to 4294967295 (×0.1%)

\* Data stored every 10 minutes.

## EXTERNAL DIMENSIONS unit: mm (inch)

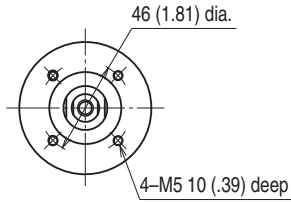
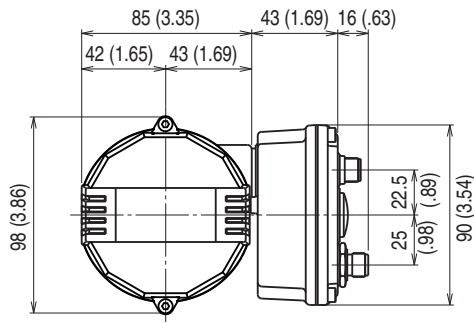

YOKE CONNECTION

### OUTPUT STEM HOLE SIZE M

CODE	DIA.	PITCH	DEPTH
6	M 6	0.75	15
8	M 8	1.0	
1	M10	1.25	
D	M 6	1.0	
E	M 8	1.25	
F	M10	1.5	

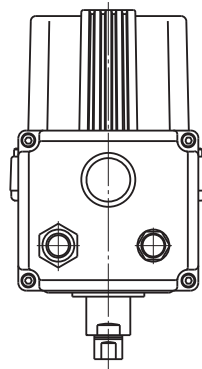
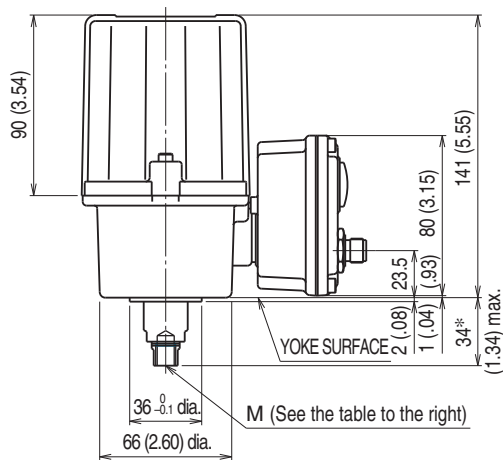

\*29 (1.14) max. for the stroke 5 - 10 mm

## SCHEMATIC CIRCUITRY

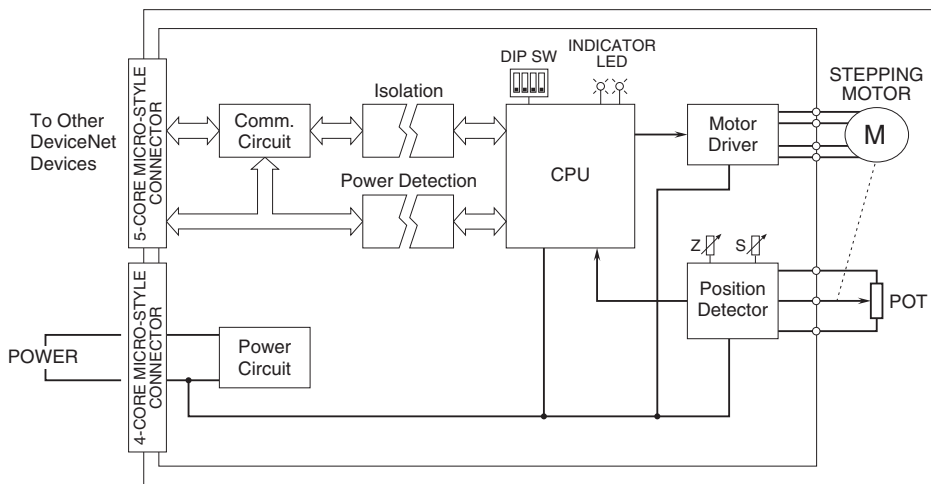

Specifications are subject to change without notice.