

Final Control Elements

MINI-TOP ELECTRONIC ACTUATOR

(linear type)

Functions & Features

- Small-size control valve actuator
- 1/1000 high resolution
- Seal-spring incorporated for pressing direction
- Easy adjustment: electronic limiter at the valve open & closed positions
- Overload protection
- Various power inputs
- Manual operation function option available

Typical Applications

- Actuator for automatic control valve in pilotplants
- Air-conditioning in buildings or plants
- Micro-flow control for pharmaceutical injection
- For small-size control valves

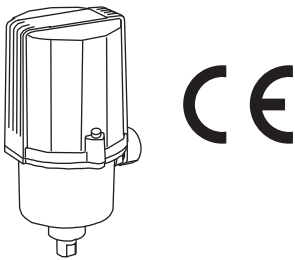

MODEL: MSP4-[1][2][3][4][5]-[6][7][8][9]

ORDERING INFORMATION

- Code number: MSP4-[1][2][3][4][5]-[6][7][8][9]
- Specify a code from below for each of [1] through [9].
(e.g. MSP4-271LT-ACR/S/Q)
- Special input range (for codes Z and 0)
- Specify the specification for option code /Q
(e.g. /SET)

[1] STROKE

- 1: 5 to 10 mm (.20" to .39")
2: 8 to 15 mm (.31" to .59")

[2] OPERATION TIME, THRUST

- 3: 5 sec. / 10 mm, 150 N
4: 9 sec. / 10 mm, 300 N
7: 18 sec. / 10 mm, 700 N

[3] OUTPUT STEM TYPE

- 6: M6 female thread, 0.75 pitch
8: M8 female thread, 1.0 pitch
1: M10 female thread, 1.25 pitch
D: M6 female thread, 1.0 pitch
E: M8 female thread, 1.25 pitch
F: M10 female thread, 1.5 pitch

[4] SEQUENTIAL CONTROL SIGNALS

- L: Full-open/-closed signal
F: Forced open/close signal
B: Full-open/-closed and forced open/close signals
(Select 'With Terminal Box.')
- 0: Without

[5] TERMINAL BOX

- T: With
0: Without

[6] INPUT

Current

- A: 4 - 20 mA DC (Input resistance 250 Ω)
Z: Specify current (See INPUT SPECIFICATIONS)

Voltage

- 6: 1 - 5 V DC (Input resistance approx. 1 MΩ)
0: Specify voltage (See INPUT SPECIFICATIONS)

[7] CE MARKING

- C: With
0: Without

[8] POWER INPUT

AC Power

- K3: 100 - 120 V AC
(Operational voltage range 90 - 132 V, 47 - 66 Hz)
(Not selectable for CE)

L3: 200 - 240 V AC

- (Operational voltage range 180 - 264 V, 47 - 66 Hz)
(Not selectable for CE)

DC Power

- R: 24 V DC
(Operational voltage range 24 V ±10 %, ripple 10 %p-p max.)

[9] OPTIONS (multiple selections)

Manual Operation Function

- blank: Without
/S: With (Not available when DC power is selected.)

Other Options

- blank: none

/Q: Option other than the above (specify the specification)

SPECIFICATIONS OF OPTION: Q

EX-FACTORY SETTING

/SET: Preset according to the Ordering Information Sheet
(No. ESU-4854)

GENERAL SPECIFICATIONS

Degree of protection: IP66

Action: Direct or reverse; field selectable with DIP switches (factory set to "reverse")

(In "reverse" action with upright mount, the output stem goes up with an input signal increase.)

Operation at abnormally low input: go up, go down or stop; moving direction when upright mount, field selectable with DIP switches (factory set to "go down")

Detectable input drop level: $-16 \pm 2.5 \%$

Electrical connection

•Without terminal box

Wiring conduit: G 1/2 female; cable connector with 1 meter wire (0.5 mm^2) provided

•Terminal box

Wiring conduit: G 1/2 female (two)

Terminal screws: M3 pillar terminal
(Sequential control signal suffix code B)
M3 chromated steel
(other terminal box types)
(torque 0.5 N·m)

Housing material: Diecast aluminum

Drive: Stepping motor

Insulation class: E

Position detection: Potentiometer

Deadband: 0.1 – 4.5 % adjustable (factory set to 1.5 %)

Restarting timer: 0 – 10 sec. adjustable
(factory set to 1.5 sec.)

Isolation: AC power to signal

Zero adjustment: 0 – 25 %

Span adjustment: 50 – 100 %

Protective functions: Overload protection

Power indicator: Green LED turns on with power supplied.

Input indicator: Green LED turns on with normal input

Status indicator LED: Red light blinks in 2 sec. intervals in normal operations; blinks in 0.5 sec. intervals when a foreign object is detected mechanically caught inside.

Manual operation: Optional

- MSP4-x3: 27 turns/mm
- MSP4-x4: 54 turns/mm
- MSP4-x7: 112 turns/mm

INPUT SPECIFICATIONS

■ **DC Current:** Input resistor incorporated (250 Ω)

■ **DC Voltage:** 1 – 5 V DC or specific range within 0 – 5 V DC, minimum span 1 V
(For a current input, convert the current to a voltage with 250 Ω)

Input resistance: Approx. 1 M Ω

■ **Forced open/close signal:** Dry contact inputs to command to go up and go down

Rating: 5 V DC @ 2.5 mA

(go up and go down when upright mount)

OUTPUT SPECIFICATIONS

■ **Operation Time & Torque** (at rated power voltage)

(Model: Operation Time: Thrust)

MSP4-x3: 5 sec. / 10 mm: 150 N (33.5 lbf)

MSP4-x4: 9 sec. / 10 mm: 300 N (67 lbf)

MSP4-x7: 18 sec. / 10 mm: 700 N (157 lbf)

■ **DC Voltage:** 1 – 5 V DC (not isolated)

With "direct" action, 5 – 1 V DC position output is provided proportionally to 4 – 20 mA DC (1 – 5 V DC) input.

Load resistance: $\geq 5 \text{ k}\Omega$

■ **Full-open / -closed signals:** Limit switch contact

Rating: 125 V AC @ 0.75 A ($\cos \phi = 1$)

30 V DC @ 0.6 A (resistive load)

Mechanical life: 3×10^7 cycles

Maximum operation frequency: 60 cycles/min.

INSTALLATION

Power consumption

•AC: Approx. 25 VA

•DC: Approx. 0.6 A

Operating temperature: -5 to +55°C (23 to 131°F)

Operating humidity: 30 to 85 %RH (non-condensing)

Vibration: 0.5 G (4.9 m/s²) max.

Mounting position: All directions

Do not mount the actuator with its output stem or cable connector on the upside if the actuator is to be exposed to dripping water.

Weight

•DC powered: 1.2 kg (2.65 lb)

•AC powered: 1.4 kg (3.09 lb)

Add 0.7 kg (1.54 lb) for the terminal box.

PERFORMANCE

Resolution: 1/1000 or 0.015 mm, whichever is greater, with 0.1 % deadband setting

Insulation resistance

•AC powered: $\geq 100 \text{ M}\Omega$ with 500 V DC

(signal or metallic housing to power)

$\geq 100 \text{ M}\Omega$ with 100 V DC

(signal to metallic housing)

• **DC powered:** $\geq 100 \text{ M}\Omega$ with 100 V DC

(signal or power to metallic housing)

Dielectric strength

• **AC powered:** 1500 V AC @ 1 minute

(signal or metallic housing to power)

100 V AC @ 1 minute

(signal to metallic housing)

• **DC powered:** 100 V AC @ 1 minute

(signal or power to metallic housing)

The Mini-Top Series incorporates a seal-spring to maintain the sealing pressure when the valve is fully closed. The standard spring has 0.5 - 1 mm (.02" - .04") flexibility to facilitate the full-closed adjustment.

STANDARDS & APPROVALS

EU conformity:

EMC Directive

EMI EN 61000-6-4

EMS EN 61000-6-2

Low Voltage Directive

EN 61010-1

Measurement Category II (Full-open/-closed signal)

Pollution Degree 2

Full-open/-closed signal to other, power or metallic housing: Reinforced insulation (125 V)

RoHS Directive

EN 50581

TERMINOLOGY

• Overload (Lock) Protection

The Mini-Top Series is equipped with a protection circuit against overload caused by for example the valve catching an alien substance.

When an overload is detected, the Mini-Top stops supplying power to the motor and the status LED blinks in 0.5 sec. intervals.

The protection is reset automatically with applying opposite-direction input signal or turning the power off and restarting.

• Restarting Timer

The Mini-Top Series is equipped with a timer circuit which gives an interval period (0 - 10 seconds) between stop-restart actions to prevent the motor and other internal components from overheating.

It is recommended to set a long restarting time when the ambient temperature and/or the temperature of flow material is high.

• Electronic Limiter

This model is equipped with electronic limiters in order to prevent mechanical locks when the input goes below 0 % or above 100 %.

Limiters are set at approx. -1.5 % for the full-closed side, approx. 101.5 % for the full-open side.

• Seal-Spring

TERMINAL CONNECTIONS

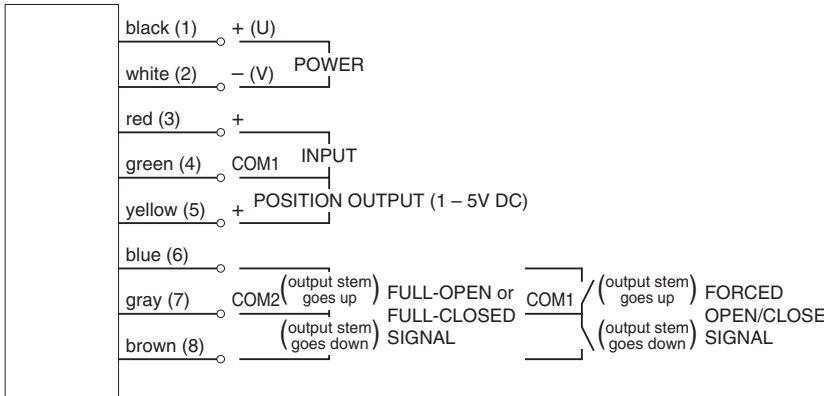

(1) to (8): Terminal No. of terminal box.
Full-open/closed signals and forced open/close signals are optional.

• With Both Full-open/closed Signal and Forced Open/Close Signal

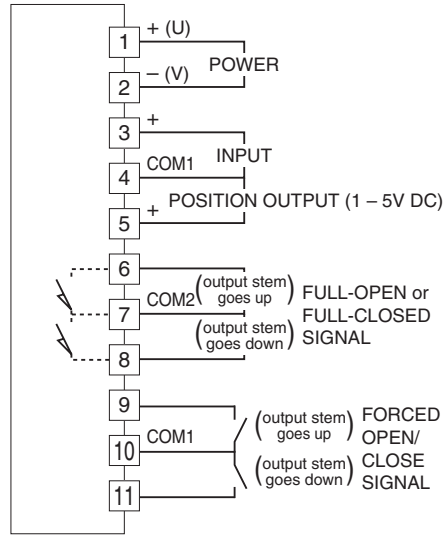

EXTERNAL DIMENSIONS unit: mm (inch)

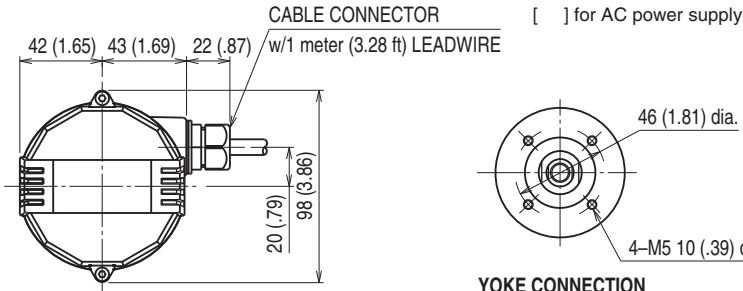

OUTPUT STEM HOLE SIZE M

CODE	DIA.	PITCH	DEPTH
6	M 6	0.75	15
8	M 8	1.0	
1	M10	1.25	
D	M 6	1.0	
E	M 8	1.25	
F	M10	1.5	

YOKE CONNECTION

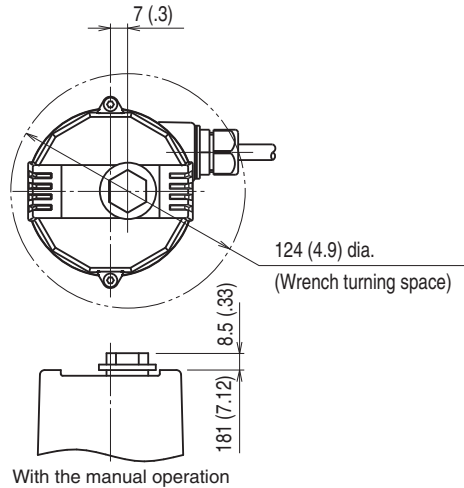
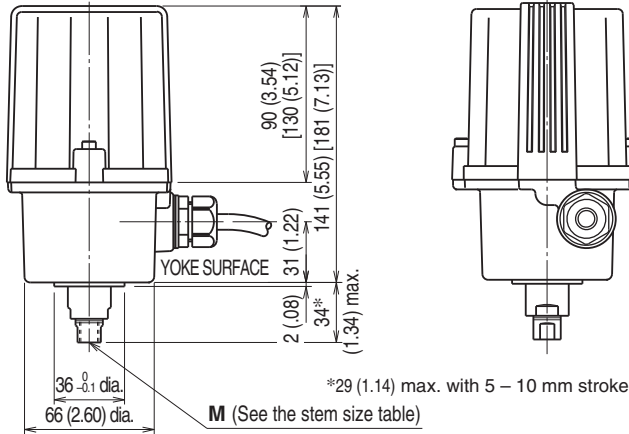

■ TERMINAL BOX TYPE

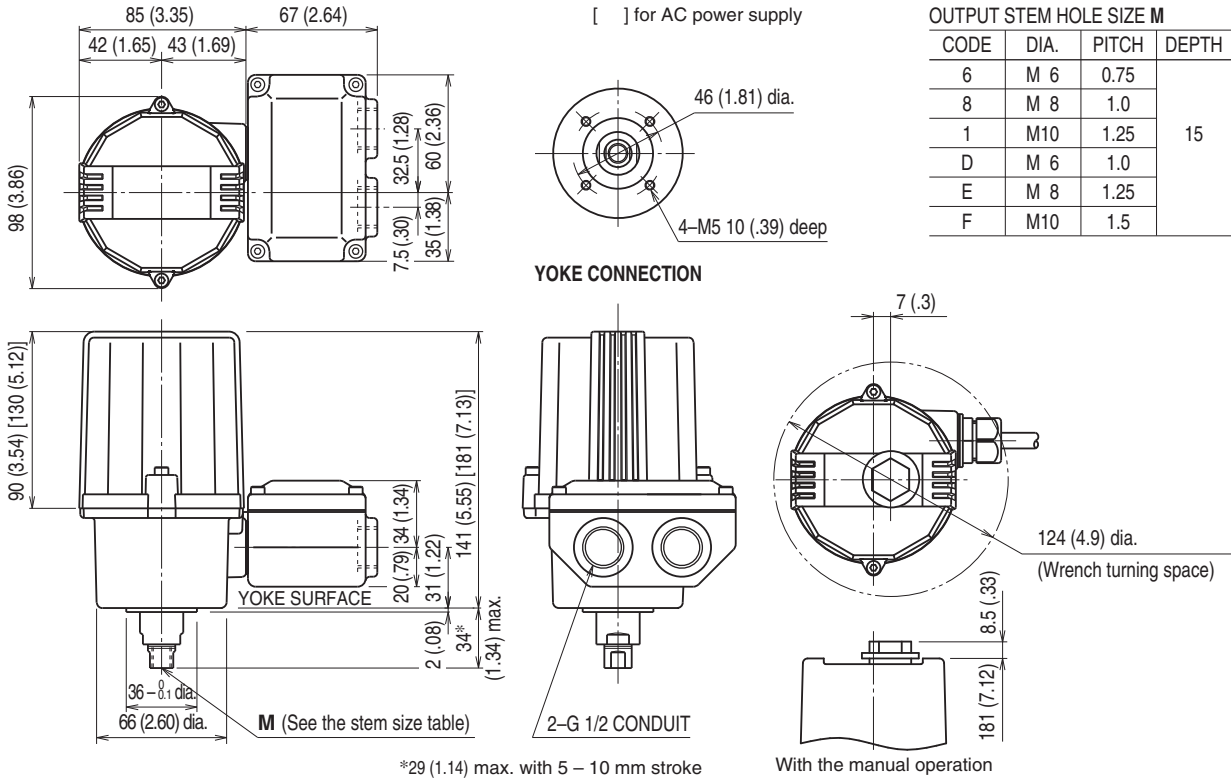

SCHEMATIC CIRCUITRY

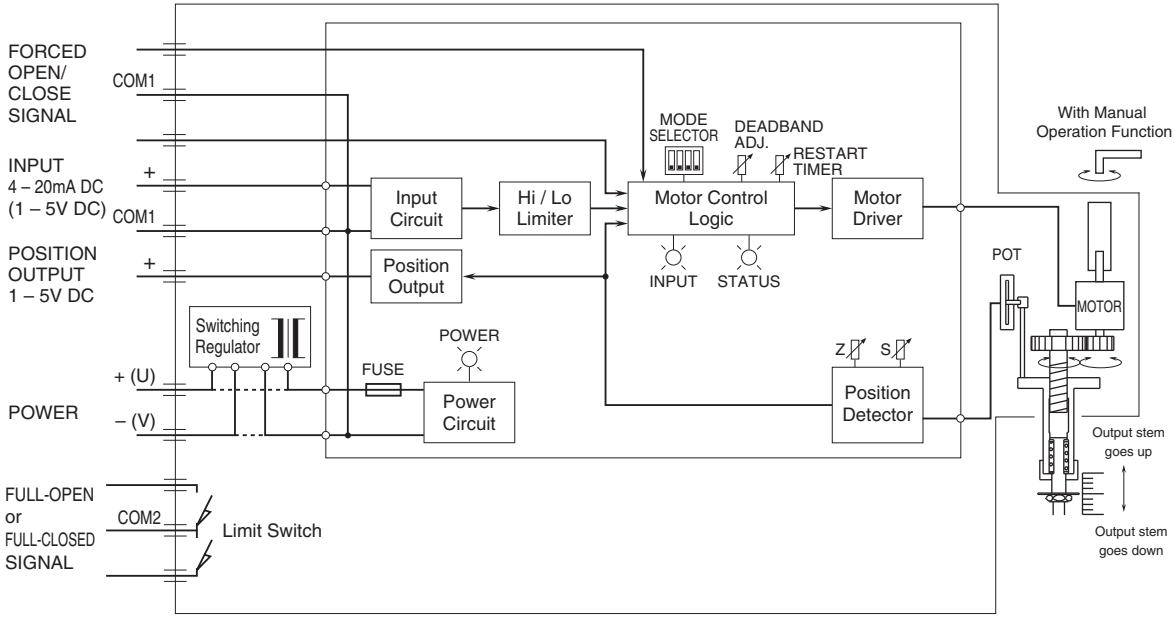

Full-open/-closed signals and forced open/close signals are optional. Disregard the switching regulator circuit for DC power input.



Specifications are subject to change without notice.