

Final Control Elements

MINI-TOP ELECTRONIC ACTUATOR

(rotary type)

Functions & Features

- Small-size control valve actuator
- 1/1000 high resolution
- Easy adjustment: electronic limiter at the valve open & closed positions
- Overload protection
- Various power inputs

Typical Applications

- Actuator for automatic control valve in pilotplants
- Air-conditioning in buildings or plants
- Micro-flow control for pharmaceutical injection
- For small-size control valves

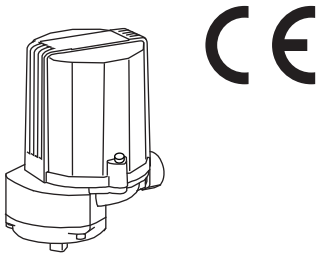

MODEL: MRP4-[1][2][3][4]-[5][6][7]

ORDERING INFORMATION

- Code number: MRP4-[1][2][3][4]-[5][6][7]
- Specify a code from below for each of [1] through [7].
(e.g. MRP4-14LT-A0R)
- Special input range (for codes Z and 0)

[1] SPAN

- 1: 45 to 90 degrees
- 2: 90 to 180 degrees

[2] OPERATION TIME, TORQUE

- 4: 7 seconds / 90°, 5 N·m
- 5: 13 seconds / 90°, 5 N·m

[3] SEQUENTIAL CONTROL SIGNALS

- L: Full-open/-closed signal
- F: Forced open/close signal
- B: Full-open/-closed and forced open/close signals
(Select 'With Terminal Box'.)
- E: Full-closed/overload signal (Not selectable for CE)

0: Without

[4] TERMINAL BOX

- T: With
- 0: Without

[5] INPUT

Current

- A: 4 - 20 mA DC (Input resistance 250 Ω)
- Z: Specify current (See INPUT SPECIFICATIONS)

Voltage

- 6: 1 - 5 V DC (Input resistance approx. 1 MΩ)
- 0: Specify voltage (See INPUT SPECIFICATIONS)

[6] CE MARKING

- C: With
- 0: Without

[7] POWER INPUT

AC Power

- K3: 100 - 120 V AC
(Operational voltage range 90 - 132 V, 47 - 66 Hz)
(Not selectable for CE)

L3: 200 - 240 V AC

- (Operational voltage range 180 - 264 V, 47 - 66 Hz)
(Not selectable for CE)

DC Power

- R: 24 V DC
(Operational voltage range 24 V ±10 %, ripple 10 %p-p max.)

GENERAL SPECIFICATIONS

Degree of protection: IP66

Action: Direct or reverse; field selectable with DIP switches
(factory set to "reverse")

(In "reverse" action, the output stem seen from the cover turns counterclockwise with an input signal increase.)

Operation at abnormally low input: Counterclockwise turn, clockwise turn or stop; field selectable with DIP switches
(factory set to "clockwise")

Note: Counterclockwise or clockwise if seen from the cover.

Detectable input drop level: -16 ±2.5 %

Electrical connection

•Without terminal box

Wiring conduit: G 1/2 female; cable connector with 1 meter wire (0.5 mm²) provided

•Terminal box

Wiring conduit: G 1/2 female (two)

Terminal screws: M3 pillar terminal
(Sequential control signal suffix code B)
M3 chromated steel

(other terminal box types)

(torque 0.5 N·m)

Housing material: Diecast aluminum

Drive: Stepping motor

Insulation class: E

Position detection: Potentiometer

Deadband: 0.1 – 4.5 % adjustable (factory set to 1.5 %)

Restarting timer: 0 – 10 sec. adjustable

(factory set to 1.5 sec.)

Isolation: AC power to signal

Zero adjustment: 0 – 25 %

Span adjustment: 50 – 100 %

Protective functions: Overload protection

Power indicator: Green LED turns on with power supplied.

Input indicator: Green LED turns on with normal input

Status indicator LED: Red light blinks in 2 sec. intervals in normal operations; blinks in 0.5 sec. intervals when a foreign object is detected mechanically caught inside.

Manual operating handle: Not available

INPUT SPECIFICATIONS

■ **DC Current:** Input resistor incorporated (250 Ω)

■ **DC Voltage:** 1 – 5 V DC or specific range within 0 – 5 V DC, minimum span 1 V

(For a current input, convert the current to a voltage with 250 Ω)

Input resistance: Approx. 1 MΩ

■ **Forced open/close signal:**

Dry contact inputs to command clockwise and counterclockwise turns

Rating: 5 V DC @ 2.5 mA

OUTPUT SPECIFICATIONS

■ **Operation Time & Torque (at rated power voltage)**

MRP4-x4: 7 sec. / 90°; torque 5 N·m (3.69 ft·lbf)

MRP4-x5: 13 sec. / 90°; torque 5 N·m (3.69 ft·lbf)

■ **DC Voltage:** 1 – 5 V DC (not isolated)

With “direct” action, 5 – 1 V DC position output is provided proportionally to 4 – 20 mA DC (1 – 5 V DC) input.

Load resistance: ≥ 5 kΩ

■ **Full-open / -closed signals:** Limit switch contact

Rating: 125 V AC @ 0.75 A (cos φ = 1)

30 V DC @ 0.6 A (resistive load)

Mechanical life: 3 × 10⁷ cycles

Maximum operation frequency: 60 cycles/min.

■ **Full-Closed/Overload Signal:** Relay contact

Full-closed signal trips at approx. 2 % of span.

Rating: 250 V AC @ 1 A (cos φ = 1)

30 V DC @ 1 A (resistive load)

INSTALLATION

Power consumption

• **AC:** Approx. 25 VA

• **DC:** Approx. 0.6 A

Operating temperature: -5 to +55°C (23 to 131°F)

Operating humidity: 30 to 85 %RH (non-condensing)

Vibration: 0.5 G (4.9 m/s²) max.

Mounting position: All directions

Do not mount the actuator with its output stem or cable connector on the upside if the actuator is to be exposed to dripping water.

Weight

DC powered: 1.1 kg (2.43 lb)

AC powered: 1.3 kg (2.87 lb)

Add 0.7 kg (1.54 lb) for the terminal box.

PERFORMANCE

Resolution: 1/1000 or 0.09°, whichever is greater, with 0.1 % deadband setting

Insulation resistance

• **AC powered:** ≥ 100 MΩ with 500 V DC (signal or metallic housing to power)

≥ 100 MΩ with 100 V DC

(signal to metallic housing)

• **DC powered:** ≥ 100 MΩ with 100 V DC

(signal or power to metallic housing)

Dielectric strength

• **AC powered:** 1500 V AC @ 1 minute

(signal or metallic housing to power)

100 V AC @ 1 minute

(signal to metallic housing)

• **DC powered:** 100 V AC @ 1 minute

(signal or power to metallic housing)

STANDARDS & APPROVALS

EU conformity:

EMC Directive

EMI EN 61000-6-4

EMS EN 61000-6-2

Low Voltage Directive

EN 61010-1

Measurement Category II (Full-open/-closed signal)

Pollution Degree 2

Full-open/-closed signal to other, power or metallic

housing: Reinforced insulation (125 V)

RoHS Directive

EN 50581

TERMINOLOGY**• Overload (Lock) Protection**

The Mini-Top Series is equipped with a protection circuit against overload caused by for example the valve catching an alien substance.

When an overload is detected, the Mini-Top stops supplying power to the motor and the status LED blinks in 0.5 sec. intervals.

The protection is reset automatically with applying opposite-direction input signal or turning the power off and restarting.

• Restarting Timer

The Mini-Top Series is equipped with a timer circuit which gives an interval period (0 - 10 seconds) between stop-restart actions to prevent the motor and other internal components from overheating.

It is recommended to set a long restarting time when the ambient temperature and/or the temperature of flow material is high.

• Electronic Limiter

This model is equipped with electronic limiters in order to prevent mechanical locks when the input goes below 0 % or above 100 %.

Limiters are set at approx. -0.5 % for the full-closed side, approx. 100.5 % for the full-open side.

• Full-open/-closed signal (limit switch contact)

The Mini-Top series is optionally equipped with full-open/-closed signal that makes at full-open or -closed position. These positions are NOT proportional to the span and/or zero adjustments.

• Full-closed/overload signal (relay contact)

The Mini-Top series is optionally equipped with full-closed/overload signal that makes at full-closed position and/or detecting overload (see "Overload Protection"). This full-closed position is proportional to the span and/or zero adjustments.

TERMINAL CONNECTIONS

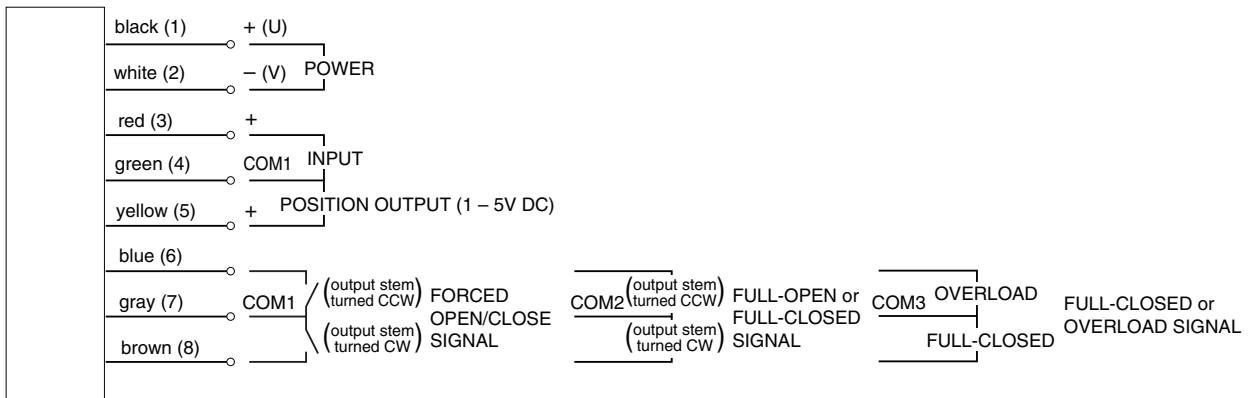

(1) to (8): Terminal No. of terminal box.

Full-open/-closed signals, forced open/close signals and full-closed/overload signals are optional.

- With Both Full-open/closed Signal and Forced Open/Close Signal

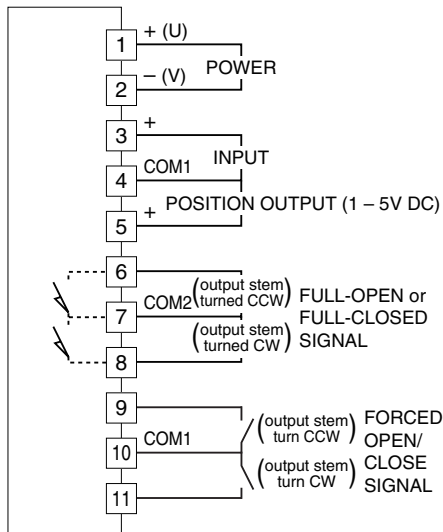

EXTERNAL DIMENSIONS unit: mm (inch)

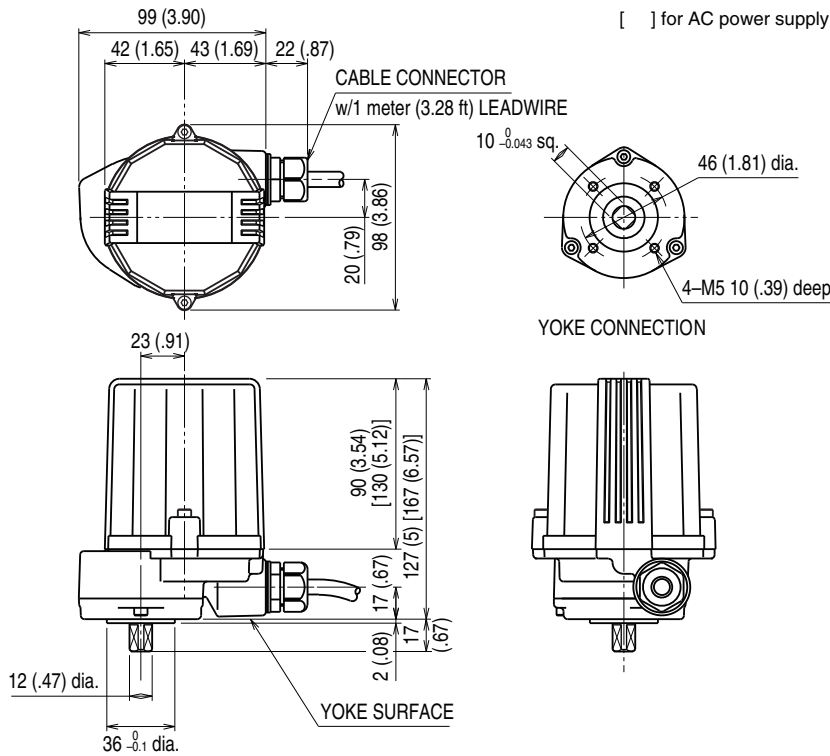

■ **TERMINAL BOX TYPE**

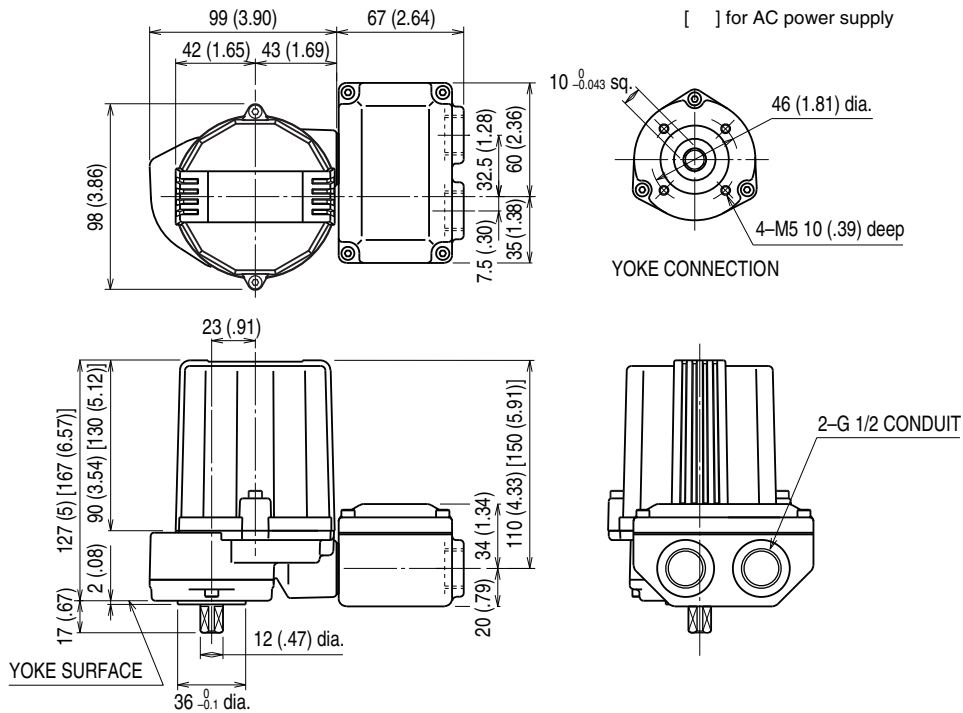

SCHEMATIC CIRCUITRY

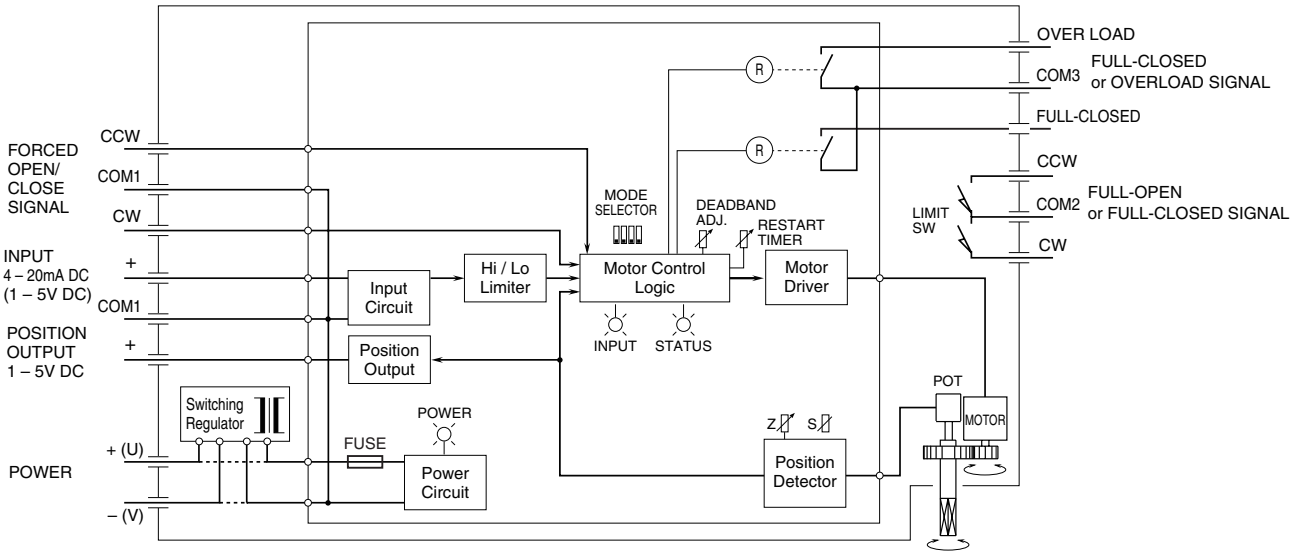

Full-open/-closed signals, forced open/close signals and full-closed/overload signals are optional. Disregard the switching regulator circuit for DC power input.



Specifications are subject to change without notice.