

## Lightning Surge Protectors for Electronics Equipment M-RESTER

### LIGHTNING SURGE PROTECTOR FOR THERMOCOUPLE USE

(ultra-slim)

#### Functions & Features

- High discharge current capacity 20 kA (8 / 20  $\mu$ s), 1 kA (10 / 350  $\mu$ s)
- Ultra-thin 7-mm-wide module can be mounted in high density
- Excellent protection employing multi-stage SPD circuits
- DIN rail mounting and grounding
- Shield terminal provided

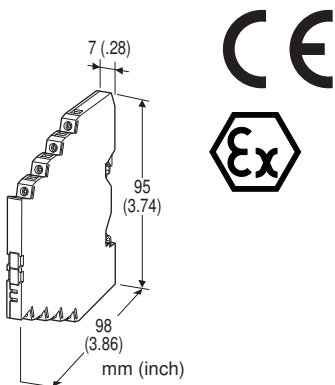

### MODEL: MD7TC-[1][2][3]

#### ORDERING INFORMATION

- Code number: MD7TC-[1][2][3]

Specify a code from below for each [1] through [3].

(e.g. MD7TC-FF0/Q)

For the safety approval code 2, specify the product's destination country using Ordering Information Sheet (No. ESU-8057).

- Specify the specification for option code /Q (e.g. /C01)

#### [1] SHIELD TERMINAL (line / earth)

FF: Floating / Floating

FG: Floating / Grounding

GF: Grounding / Floating

GG: Grounding / Grounding

#### [2] SAFETY APPROVAL

0: None

2: CENELEC intrinsic safety (ATEX)

#### [3] OPTIONS

blank: none

/Q: With options (specify the specification)

(CENELEC intrinsic safety (ATEX) not available)

#### SPECIFICATIONS OF OPTION: Q

**COATING (For the detail, refer to M-System's web site.)**

/C01: Silicone coating

/C02: Polyurethane coating

#### GENERAL SPECIFICATIONS

**Construction:** Slim-sized front terminal structure

**Degree of protection:** IP20

**Connection:** Euro terminal block (torque 0.3 N·m)

**Applicable wire size:** 0.2 - 2.5 mm<sup>2</sup>, stripped length 8 mm

**Grounding:** DIN Rail

**Housing material:** Flame-resistant resin (black)

#### INSTALLATION

**Operating temperature:** -25 to +85°C (-13 to +185°F)

(See Safety Parameters for use in a hazardous location.)

**Operating humidity:** 30 to 90 %RH (non-condensing)

**Mounting:** DIN Rail (TH35-7.5, 1-mm-thick)

Oxide film on the surface of an aluminium DIN rail may lower the electric conductivity between this module and the ground. Use a steel or copper rail.

**Weight:** 70 g (2.5 oz)

## PERFORMANCE

MODEL NO.		MD7TC-FF	MD7TC-FG	MD7TC-GF	MD7TC-GG
Max. continuous operating voltage (Uc)	Line to Line	7.5V			
	Line to Earth	±160V			±7.5V
	Line to SHLD	±160V		±7.5V	
	SHLD to Earth	±160V	short	±160V	short
Voltage protection level (Up) @4kV (1.2 / 50 μs)	Line to Line	25V			
	Line to Earth	±800V			±25V
	Line to SHLD	±1200V	±800V	±25V	
	SHLD to Earth	±800V	short	±800V	short
Leakage current @Uc	Line to Line	≤ 5μA			
	Other sections	≤ 5μA			
Response time	Line to Line	≤ 4 nsec.			
	Other sections	≤ 20 nsec.			
Max. discharge current (Imax)	20kA (8 / 20 μs), 1.0kA (10 / 350 μs)				
Nominal current (In)	100mA				
Internal series resistance	4.7Ω ±10% per line				
Surge protection	IEC 61643-21 Categories C1, C2, D1				

## STANDARDS & APPROVALS

### EU conformity:

ATEX Directive

Ex ia EN 60079-11

EMC Directive

EMI EN 61000-6-4

EMS EN 61000-6-2

RoHS Directive

EN 50581

### Safety approval:

CENELEC: Intrinsic safety (ATEX)

⊕ II 1G, Ex ia IIC; T4 and T5

EN 60079-0

EN 60079-11

## SAFETY PARAMETERS

### ■ CENELEC / ATEX IS DATA

Ui (Vmax)	16V		
li (Imax)	any		
Ci	35 nF		
Li	0 μH		
Pi	Temp. Class	Range	Parameter
	T4	-25 to +40°C	1.3W
		-25 to +60°C	1.2W
		-25 to +80°C	1.0W
	T5	-25 to +40°C	1.0W

## DESCRIPTIONS

### ■ SELECTING SHIELD TERMINAL TYPE

- The surge protector has a dedicated shield terminal effective for easy shield wiring and surge protection.
- Review the shield method (grounding, non-grounding, connecting to SG, etc.) required by the protected device or system.
- There is no electrical effect to the shield by installing the surge protector, but an appropriate shield terminal type must be selected to suit user applications.
- Refer to the flow chart below to choose.

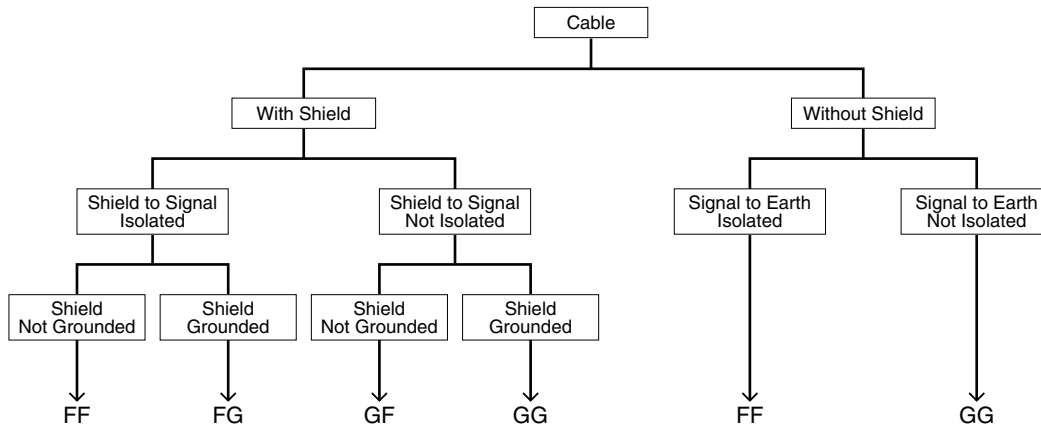

## CONNECTION EXAMPLES

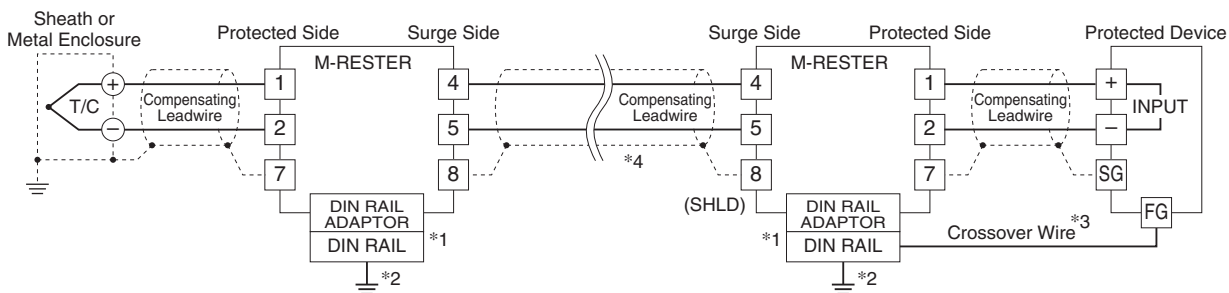

- \*1. Oxide film on the surface of an aluminium rail may lower the electric conductivity between this module and the ground. Use a steel or copper rail.
- \*2. Be sure to ground the DIN rail. Recommended grounding resistance  $\leq 1000\Omega$
- \*3. Cross-wire between the DIN rail and the metal housing of the protected device to equalize the earth potential. Ground only the surge protector when the protected device has no ground terminal.
- \*4. Shield wiring method is an example. Proceed according to the system requirements.

**EXTERNAL DIMENSIONS & TERMINAL ASSIGNMENTS unit: mm (inch)**

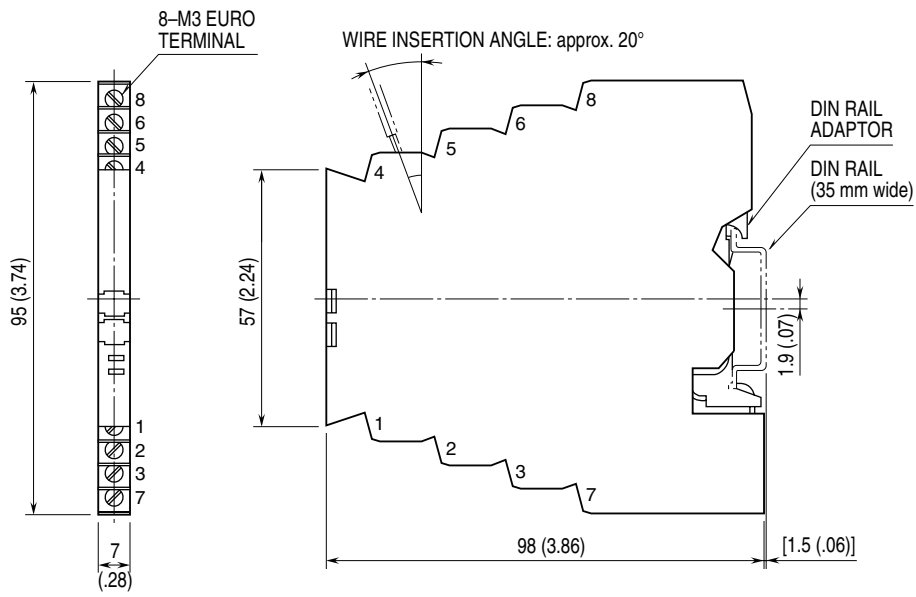

**SCHEMATIC CIRCUITRY**

SHIELD TERMINAL	MODEL NO.	SCHEMATIC CIRCUITRY	APPLICATIONS
<ul style="list-style-type: none"> <li>Line to SHLD: Floating</li> <li>Earth to SHLD: Floating</li> </ul>	<ul style="list-style-type: none"> <li>MD7TC-FFx</li> </ul>		<ul style="list-style-type: none"> <li>Standard type</li> <li>To protect a device having isolation between Signal and Earth.</li> <li>When SHLD should be floating against the earth. (single-end grounding)</li> </ul>
<ul style="list-style-type: none"> <li>Line to SHLD: Floating</li> <li>Earth to SHLD: Grounding</li> </ul>	<ul style="list-style-type: none"> <li>MD7TC-FGx</li> </ul>		<ul style="list-style-type: none"> <li>To protect a device having isolation between Signal and Earth.</li> <li>When SHLD should be grounded. (single- or both-end grounding)</li> </ul>
<ul style="list-style-type: none"> <li>Line to SHLD: Grounding</li> <li>Earth to SHLD: Floating</li> </ul>	<ul style="list-style-type: none"> <li>MD7TC-GFx</li> </ul>		<ul style="list-style-type: none"> <li>To protect a device having isolation between Signal and Earth.</li> <li>When SHLD wire should be connected to SG terminal of the protected device. (SHLD is not grounded to the earth.)</li> </ul>
<ul style="list-style-type: none"> <li>Line to SHLD: Grounding</li> <li>Earth to SHLD: Grounding</li> </ul>	<ul style="list-style-type: none"> <li>MD7TC-GGx</li> </ul>		<ul style="list-style-type: none"> <li>To protect a device which does not have a good dielectric strength between Signal and Earth.</li> </ul>

Sections enclosed with broken line may differ depending upon the models.



Specifications are subject to change without notice.