

Lightning Surge Protectors for Electronics Equipment M-RESTER

LIGHTNING SURGE PROTECTOR FOR PROFIBUS-PA

(ultra-slim)

Functions & Features

- High discharge current capacity 20 kA (8 / 20 μ s), 1 kA (10 / 350 μ s)
- Ultra-thin 7-mm-wide module can be mounted in high density
- Excellent protection employing multi-stage SPD circuits
- DIN rail mounting and grounding
- Shield terminal provided
- Conforms with FISCO

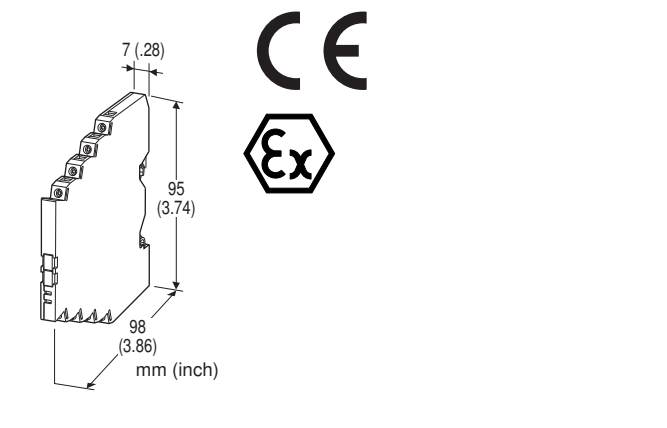

MODEL: MD7PA-[1][2][3]

ORDERING INFORMATION

- Code number: MD7PA-[1][2][3]

Specify a code from below for each [1] through [3].

(e.g. MD7PA-FF0/Q)

For the safety approval code 2, specify the product's destination country using Ordering Information Sheet (No. ESU-8057).

- Specify the specification for option code /Q (e.g. /C01)

[1] SHIELD TERMINAL (to earth)

FF: Floating

FG: Grounding

[2] SAFETY APPROVAL

0: None

2: CENELEC intrinsic safety (ATEX)

[3] OPTIONS

blank: none

/Q: With options (specify the specification)

(CENELEC intrinsic safety (ATEX) not available)

SPECIFICATIONS OF OPTION: Q

COATING (For the detail, refer to M-System's web site.)

/C01: Silicone coating

/C02: Polyurethane coating

APPLICABLE NETWORK

PROFIBUS-PA and other networks complied with

IEC 61158-2

Caution: Power supply to the bus must be limited to 400 mA or less.

GENERAL SPECIFICATIONS

Construction: Slim-sized front terminal structure

Degree of protection: IP20

Connection: Euro terminal block (torque 0.3 N·m)

Applicable wire size: 0.2 - 2.5 mm², stripped length 8 mm

Grounding: DIN Rail

Housing material: Flame-resistant resin (black)

INSTALLATION

Operating temperature: -25 to +85°C (-13 to +185°F)

(See Safety Parameters for use in a hazardous location.)

Operating humidity: 30 to 90 %RH (non-condensing)

Mounting: DIN Rail (TH35-7.5, 1-mm-thick)

Oxide film on the surface of an aluminium DIN rail may lower the electric conductivity between this module and the ground. Use a steel or copper rail.

Weight: 70 g (2.5 oz)

PERFORMANCE

	LINE TO LINE	LINE TO EARTH	SHLD TO EARTH
Max. continuous operating voltage (Uc)	±32V	±160V	±160V*1
Voltage protection level (Up) @4kV (1.2 / 50 μ s)	±60V	±800V	±800V*1
Leakage current @Uc	≤ 5 μ A	≤ 5 μ A	≤ 5 μ A*1
Response time	≤ 4 nsec.	≤ 20 nsec.	≤ 20 nsec.*1
Approx. capacitance @10 kHz	1500 pF	100 pF	100 pF*1
Max. discharge current (Imax)	20kA (8 / 20 μ s) 1.0kA (10 / 350 μ s)		
Nominal current (In)	400mA		
Internal series resistance	1.5 Ω ±10% per line		
Surge protection	IEC 61643-21 Categories C1, C2, D1		

*1. Values for the floating type (FF). Shortcircuited for the grounding type (FG).

STANDARDS & APPROVALS

EU conformity:

ATEX Directive

Ex ia EN 60079-11

EMC Directive

EMI EN 61000-6-4

EMS EN 61000-6-2

RoHS Directive

EN 50581

Safety approval:

CENELEC: Intrinsic safety (ATEX)

⊕ II 1G, Ex ia IIC; T4 and T5

EN 60079-0

EN 60079-11

SAFETY PARAMETERS

■ CENELEC / ATEX IS DATA

	Linear Barrier		FISCO Supply	
Ui (Vmax)	32V		17.5V	
Ii (Imax)	any		400mA	
Ci	5 nF		5 nF	
Li	0 μH		0 μH	
Pi	Temp. Class	Range	Parameter	
		T4	-25 to +40°C	1.3W
			-25 to +60°C	1.2W
	T5	-25 to +80°C	1.0W	
		-25 to +40°C	1.0W	
			5.4W	

EXTERNAL DIMENSIONS & TERMINAL ASSIGNMENTS unit: mm (inch)

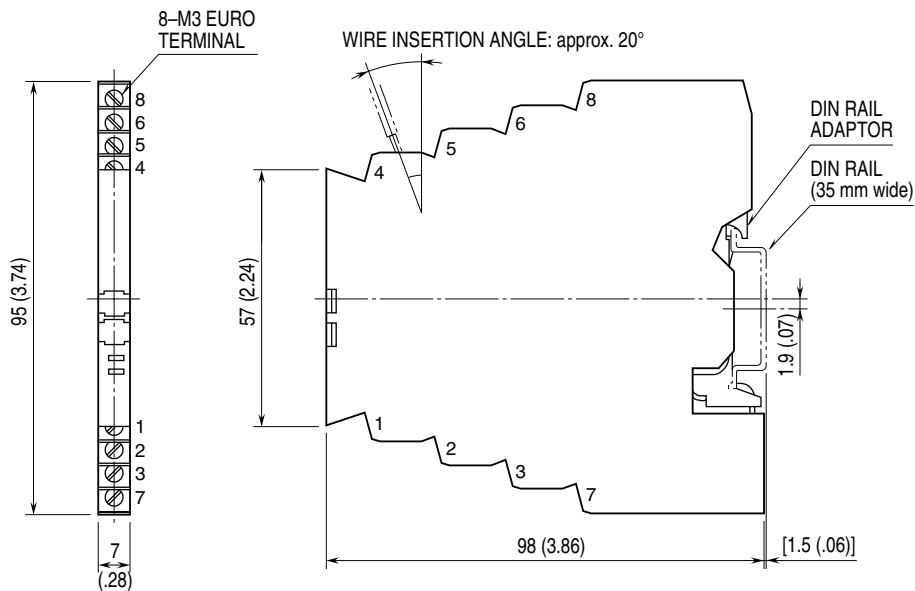

SCHEMATIC CIRCUITRY & CONNECTION DIAGRAM

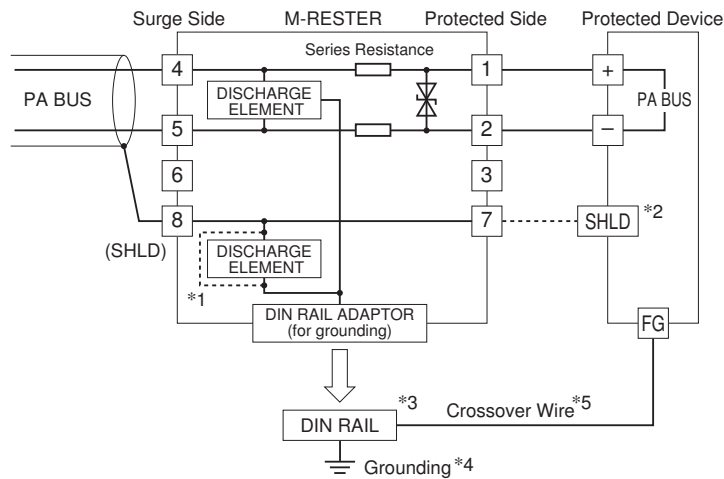

- *1. Choose the grounding (FG) when the shield wire is to be grounded.
- *2. When SHLD is not isolated from PA BUS, DO NOT connect the surge protector's terminal 7 to SHLD.
- *3. Oxide film on the surface of an aluminium rail may lower the electric conductivity between this module and the ground. Use a steel or copper rail.
- *4. Be sure to ground the DIN rail. Recommended grounding resistance max. 100 ohms.
- *5. Cross-wire from the DIN rail to the metal housing of the protected device to equalize the ground potential. Ground only the surge protector when the protected device has no grounding terminal.

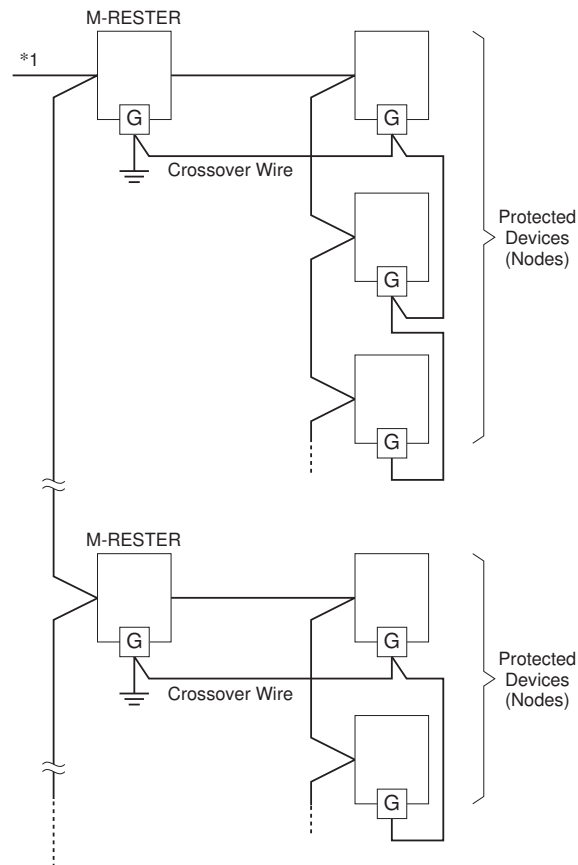

- *1. Fieldbus devices complying with IEC 61158-2 operate by a supply voltage between 9V and 32V DC. Take the MD7PA's internal series resistance into consideration when determining the cable distance if there is a large current flow on the bus line.

When the distance between nodes are relatively long (e.g. grouped and separated by cabinets), install the MD7PA by each group of devices. Insert the MD7PA at the surge side of the network. For detailed information on the network, refer to that provided by PROFIBUS International.



Specifications are subject to change without notice.