

Lightning Surge Protectors for Electronics Equipment M-RESTER

LIGHTNING SURGE PROTECTOR FOR LonWorks

(ultra-slim, FTT-10A)

Functions & Features

- High discharge current capacity 20 kA (8 / 20 μ s), 1 kA (10 / 350 μ s)
- Ultra-thin 7-mm-wide module can be mounted in high density
- Excellent protection employing multi-stage SPD circuits
- DIN rail mounting and grounding
- Shield terminal provided

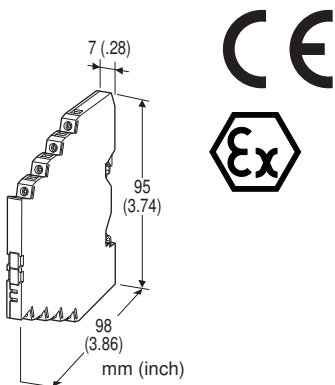

MODEL: MD7LWA-[1][2]

ORDERING INFORMATION

- Code number: MD7LWA-[1][2]
Specify a code from below for each [1] and [2].
(e.g. MD7LWA-FF/Q)
For the safety approval code /E2, specify the product's destination country using Ordering Information Sheet (No. ESU-8060).
- Specify the specification for option code /Q
(e.g. /C01)

[1] SHIELD TERMINAL (to earth)

FF: Floating
FG: Grounding

[2] OPTIONS

Safety Approval

blank: Without
/E2: CENELEC intrinsic safety (ATEX)

Other Options

blank: none

/Q: Option other than the above (specify the specification)
(CENELEC intrinsic safety (ATEX) not available)

SPECIFICATIONS OF OPTION: Q

COATING (For the detail, refer to M-System's web site.)

- /C01: Silicone coating
- /C02: Polyurethane coating

APPLICABLE NETWORK

LonWorks FTT-10A network

This unit is not applicable to LonWorks Link Power network.

GENERAL SPECIFICATIONS

Construction: Slim-sized front terminal structure

Degree of protection: IP20

Connection: Euro terminal block (torque 0.3 N·m)

Applicable wire size: 0.2 - 2.5 mm², stripped length: 8 mm

Grounding: DIN Rail

Housing material: Flame-resistant resin (black)

INSTALLATION

Operating temperature: -25 to +85°C (-13 to +185°F)

(See Safety Parameters for use in a hazardous location.)

Operating humidity: 30 to 90 %RH (non-condensing)

Mounting: DIN Rail (TH35-7.5, 1-mm-thick)

Oxide film on the surface of an aluminium DIN rail may lower the electric conductivity between this module and the ground. Use a steel or copper rail.

Weight: 70 g (2.5 oz)

PERFORMANCE

*1. Values for the floating type (FF). Shortcircuited for the grounding type (FG).

	LINE TO LINE	LINE TO EARTH	SHLD TO EARTH
Max. continuous operating voltage (Uc)	±1.5V	±100V	±160V* ¹
Voltage protection level (Up) @4kV (1.2 / 50 μ s)	±30V	±370V	±800V* ¹
Leakage current @Uc	≤5 μ A	≤20 μ A	≤5 μ A* ¹
Response time	≤4 nsec.	≤20 nsec.	≤20 nsec.* ¹
Approx. capacitance @10 kHz	100 pF	100 pF	5 pF* ¹
Max. discharge current (Imax)	20kA (8 / 20 μ s) 1.0kA (10 / 350 μ s)		
Nominal current (IN)	100mA		
Internal series resistance	≤3.3 Ω including return		
Insertion loss	-0.5 dB max. @DC...5 MHz, Z ₀ = 100 Ω		

STANDARDS & APPROVALS

EU conformity:

ATEX Directive

Ex ia EN 60079-11

EMC Directive

EMI EN 61000-6-4

EMS EN 61000-6-2

RoHS Directive

EN 50581

Safety approval:

CENELEC: Intrinsic safety (ATEX)

⊕ II 1G, Ex ia IIC; T4 and T5

EN 60079-0

EN 60079-11

Surge protection: IEC 61643-21

(Categories C1, C2, D1)

SAFETY PARAMETERS

■ CENELEC / ATEX IS DATA

Ui (Vmax)	7V		
Ii (Imax)	any		
Ci	50 nF		
Li	0 μH		
Pi	Temp. Class	Range	Parameter
	T4	-25 to +40°C	1.3W
		-25 to +60°C	1.2W
		-25 to +80°C	1.0W
T5	-25 to +40°C	1.0W	

EXTERNAL DIMENSIONS & TERMINAL ASSIGNMENTS unit: mm (inch)

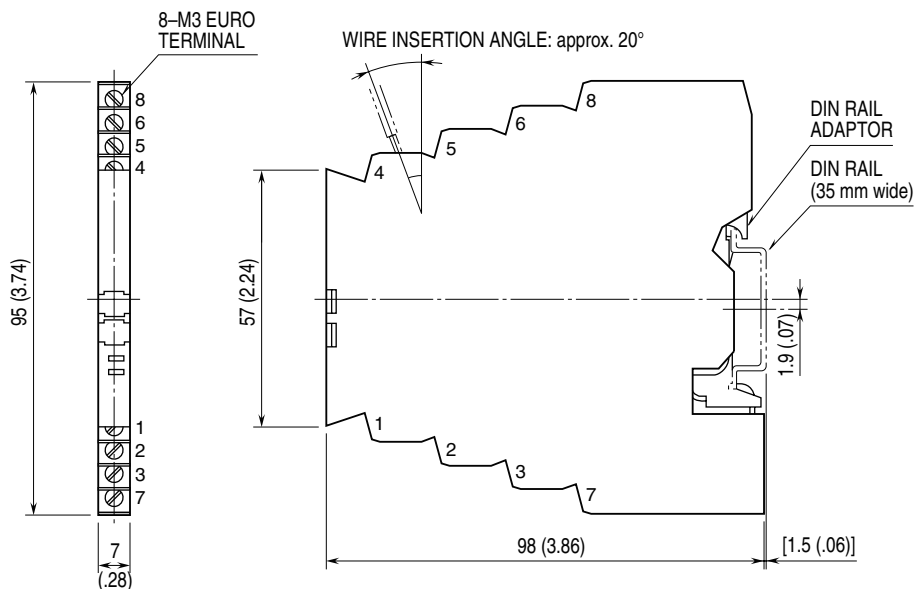

SCHEMATIC CIRCUITRY & CONNECTION DIAGRAM

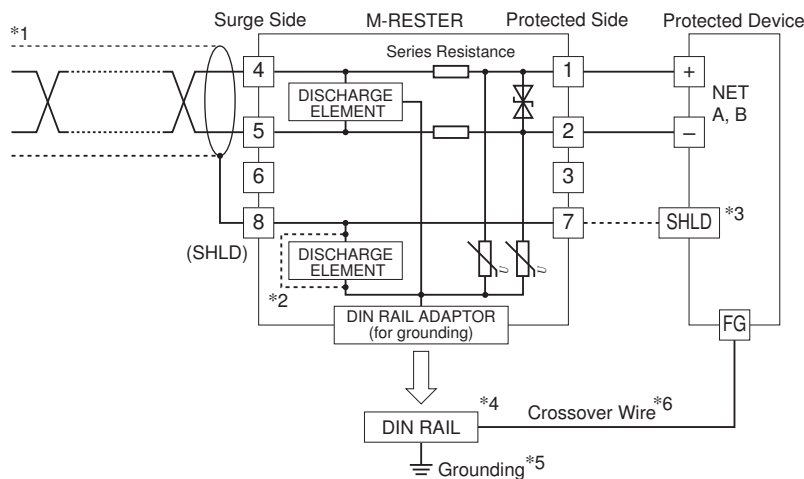

- *1. Be sure to use twisted-pair cables.
- *2. Choose the M-RESTER – FG when the shield wire is to be grounded.
- *3. When the twisted-pair cable is with a shield, connect it to the surge protector's terminal 8, and follow instructions given by the protected device for the terminal 7. When SHLD is not isolated from NET A / B, DO NOT connect the terminal 7 to SHLD.
- *4. Oxide film on the surface of an aluminium rail may lower the electric conductivity between this module and the ground. Use a steel or copper rail.
- *5. Be sure to ground the DIN rail. Recommended grounding resistance max. 100 ohms.
- *6. Cross-wire from the DIN rail to the metal housing of the protected device to equalize the ground potential. Ground only the surge protector when the protected device has no grounding terminal.

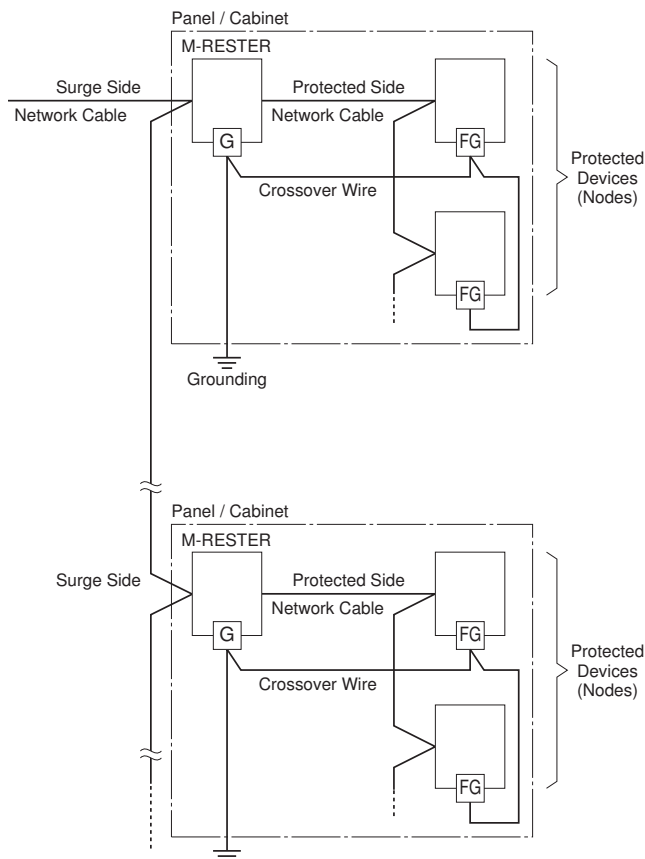

- The M-RESTER is applicable to networks which consist only of FTT-10A. Not applicable to the ones connected to Link Power network.
- The maximum number of nodes connectable to the network segment is reduced by one when one unit of M-RESTER is added.
- When the distance between nodes are relatively long (e.g. grouped and separated by cabinets), install the M-RESTER by each group of devices. Insert the M-RESTER at the surge side of the network.
- For detailed information on the network, refer to LONWORKS FTT-10A Free Topology Transceiver User's Guide provided by Echelon.



Specifications are subject to change without notice.