

Lightning Surge Protectors for Electronics Equipment M-RESTER

LIGHTNING SURGE PROTECTOR FOR SELF-SYNCH (ultra-slim)

Functions & Features

- High discharge current capacity 20 kA (8 / 20 μ s), 1 kA (10 / 350 μ s)
- Ultra-thin 7-mm-wide module can be mounted in high density
- Excellent protection employing multi-stage SPD circuits
- DIN rail mounting and grounding
- Shield terminal provided
- Protects self-synch transmitters and converters

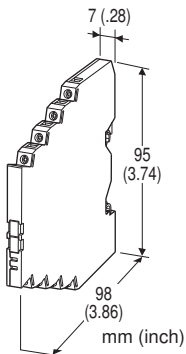

MODEL: MD7JS[1]

ORDERING INFORMATION

- Code number: MD7JS[1]
Specify a code from below for [1].
(e.g. MD7JS/Q)
- Specify the specification for option code /Q
(e.g. /C01)

[1] OPTIONS

blank: none

/Q: With options (specify the specification)

SPECIFICATIONS OF OPTION: Q

COATING (For the detail, refer to M-System's web site.)

/C01: Silicone coating

/C02: Polyurethane coating

GENERAL SPECIFICATIONS

Construction: Slim-sized front terminal structure

Degree of protection: IP20

Connection: Euro terminal block (torque 0.3 N·m)

Applicable wire size: 0.2 - 2.5 mm², stripped length 8 mm

Grounding: DIN Rail

Housing material: Flame-resistant resin (black)

INSTALLATION

Operating temperature: -25 to +55°C (-13 to +131°F)
(-5 to +40°C or 23 to 104°F, 30 to 80 % RH non-condensing, for EU conformity.)

Operating humidity: 30 to 90 % RH (non-condensing)
(-5 to +40°C or 23 to 104°F, 30 to 80 % RH non-condensing, for EU conformity.)

Mounting: DIN Rail (TH35-7.5, 1-mm-thick)

Oxide film on the surface of an aluminium DIN rail may lower the electric conductivity between this module and the ground. Use a steel or copper rail.

Weight: 70 g (2.5 oz)

PERFORMANCE

Max. continuous operating voltage (Uc):

Line to line: \pm 130 V

Line to earth: \pm 160 V

Voltage protection level (Up) @ 6 kV (1.2 / 50 μ s)

Line to line: \pm 450 V

Line to earth: \pm 800 V

Response time:

Line to line: \leq 4 nsec.

Line to earth: \leq 20 nsec.

Leakage current @ Uc:

Line to line: \leq 20 μ A

Line to earth: \leq 5 μ A

Max. discharge current (Imax): 20 kA (8 / 20 μ s); 1.0 kA (10 / 350 μ s)

Nominal current (In): 500 mA

Internal series resistance: 2 Ω \pm 10 % per line

Surge protection: IEC 61643-21 Categories C1, C2, D1

EN 61643-21 Categories C1, C2, D1

STANDARDS & APPROVALS

EU conformity:

EMC Directive

EMI EN 61000-6-4

EMS EN 61000-6-2

Low Voltage Directive

EN 61643-21

RoHS Directive

EN 50581

EXTERNAL DIMENSIONS & TERMINAL ASSIGNMENTS unit: mm (inch)

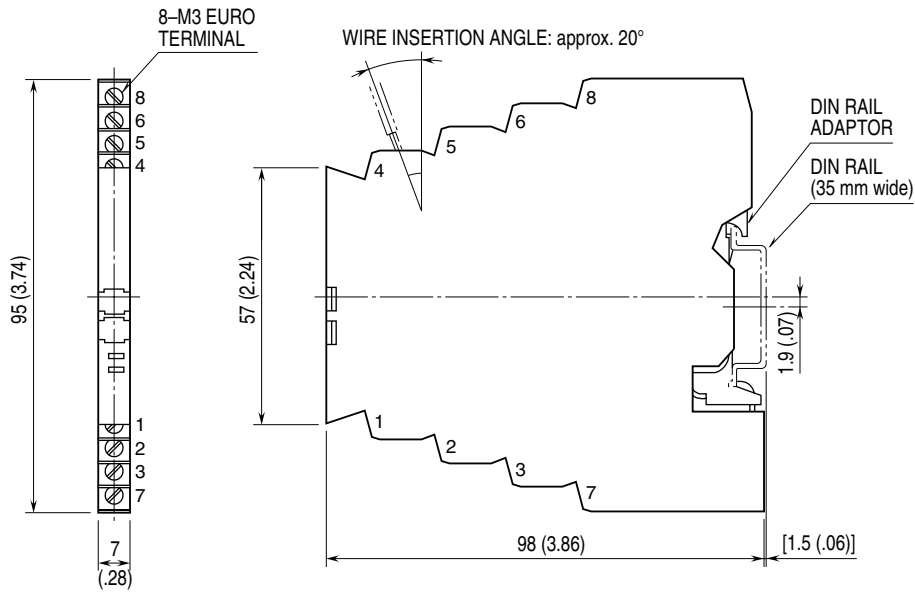

SCHEMATIC CIRCUITRY & CONNECTION DIAGRAM

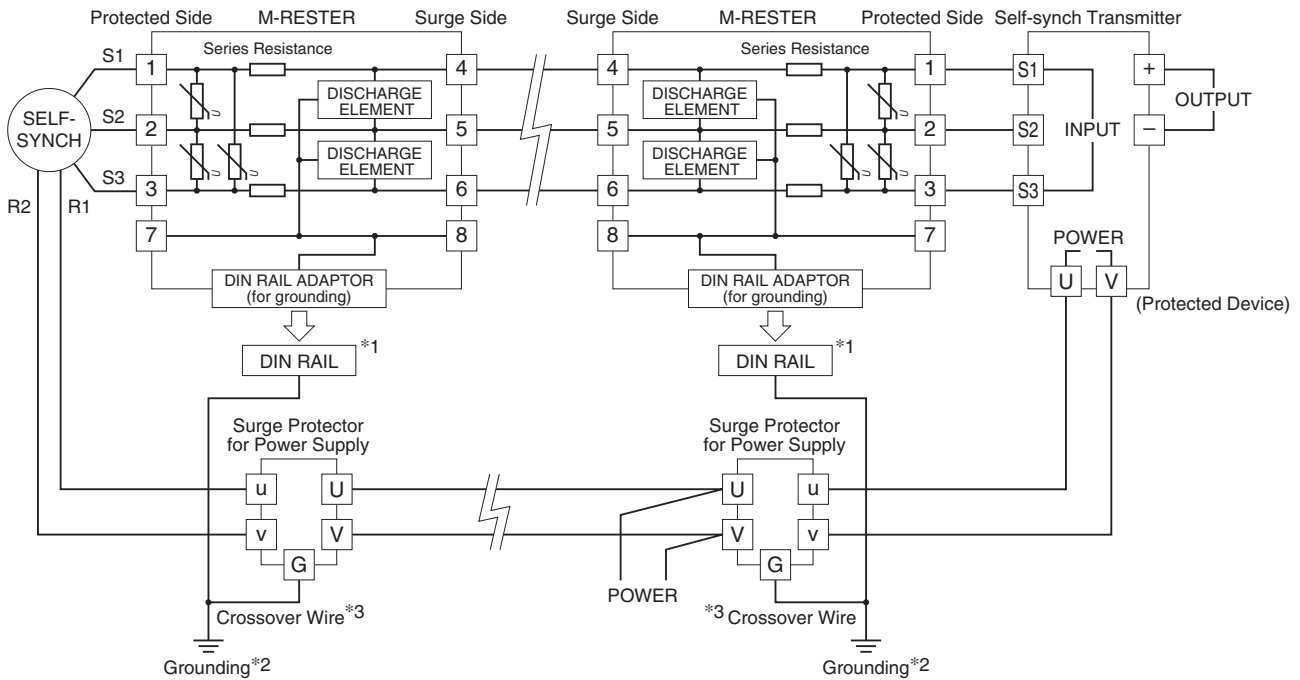

- *1. Oxide coating of an aluminium rail may lower the electric conductivity between this module and the ground. Use a steel or copper rail.
- *2. Be sure to ground the DIN rail. Recommended grounding resistance $\leq 100 \Omega$
- *3. Cross-wire between the DIN rail and the metal housing of the protected device to equalize the earth potential. Ground only the surge protector when the protected device has no ground terminal.

! Specifications are subject to change without notice.