

Lightning Surge Protectors for Electronics Equipment M-RESTER

LIGHTNING SURGE PROTECTOR FOR DC POWER SUPPLY

(max. 1.2 A; ultra-slim)

Functions & Features

- High discharge current capacity 20 kA (8/20 μ s), 1 kA (10/350 μ s)
- Ultra-thin 7-mm-wide module can be mounted in high density
- Excellent protection employing multi-stage SPD circuits
- DIN rail mounting and grounding
- Shield terminal provided

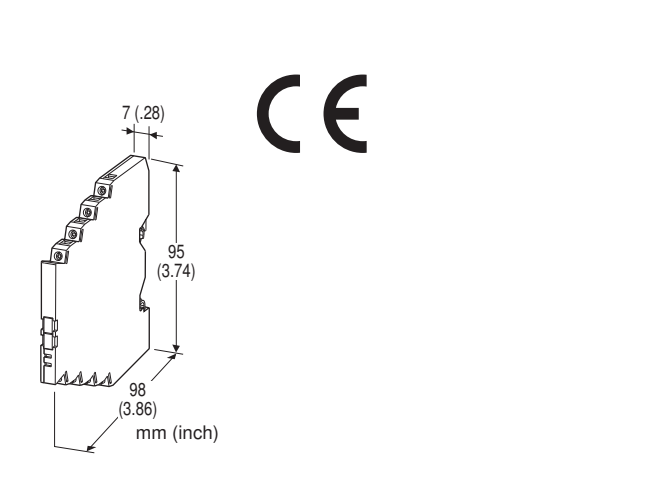

MODEL: MD7DP-[1][2]

ORDERING INFORMATION

- Code number: MD7DP-[1][2]
- Specify a code from below for each [1] and [2].
(e.g. MD7DP-24/Q)
- Specify the specification for option code /Q
(e.g. /C01)

[1] NOMINAL VOLTAGE

12: 12 V DC

24: 24 V DC

[2] OPTIONS

blank: none

/Q: With options (specify the specification)

SPECIFICATIONS OF OPTION: Q

COATING (For the detail, refer to M-System's web site.)

/C01: Silicone coating

/C02: Polyurethane coating

GENERAL SPECIFICATIONS

Construction: Slim-sized front terminal structure

Degree of protection: IP20

Connection: Euro terminal block (torque 0.3 N·m)

Applicable wire size: 0.2 - 2.5 mm², stripped length 8 mm

Grounding: DIN Rail

Housing material: Flame-resistant resin (black)

Monitor LED: Green LED turns ON when the voltage is supplied; OFF when the safety fuse is blown.

INSTALLATION

DC power supply: Max. output current 1.2 A

Caution: Use a DC power source with the overload current protection function.

Operating temperature: -25 to +85°C (-13 to +185°F)

Operating humidity: 30 to 90 %RH (non-condensing)

Mounting: DIN Rail (TH35-7.5, 1-mm-thick)

Oxide film on the surface of an aluminium DIN rail may lower the electric conductivity between this module and the ground. Use a steel or copper rail.

Weight: 70 g (2.5 oz)

PERFORMANCE

	LINE TO LINE		LINE TO EARTH
	MD7DP-12	MD7DP-24	
Max. continuous operating voltage (Uc)	14V	27V	±160V
Voltage protection level (Up) @4kV (1.2 / 50 μ s)	±150V	±170V	±1200V
Leakage current @Uc	≤ 6mA	≤ 6mA	≤ 5 μ A
Response time	≤ 4 nsec.	≤ 4 nsec.	≤ 20 nsec.
Max. discharge current (Imax)	20kA (8 / 20 μ s)		
	1.0kA (10 / 350 μ s)		
Nominal current (In)	1.2A		
Internal series resistance	≤ 0.8 Ω including return		
Surge protection	IEC 61643-21 Categories C1, C2, D1		

STANDARDS & APPROVALS

EU conformity:

EMC Directive

EMI EN 61000-6-4

EMS EN 61000-6-2

RoHS Directive

EN 50581

EXTERNAL DIMENSIONS & TERMINAL ASSIGNMENTS unit: mm (inch)

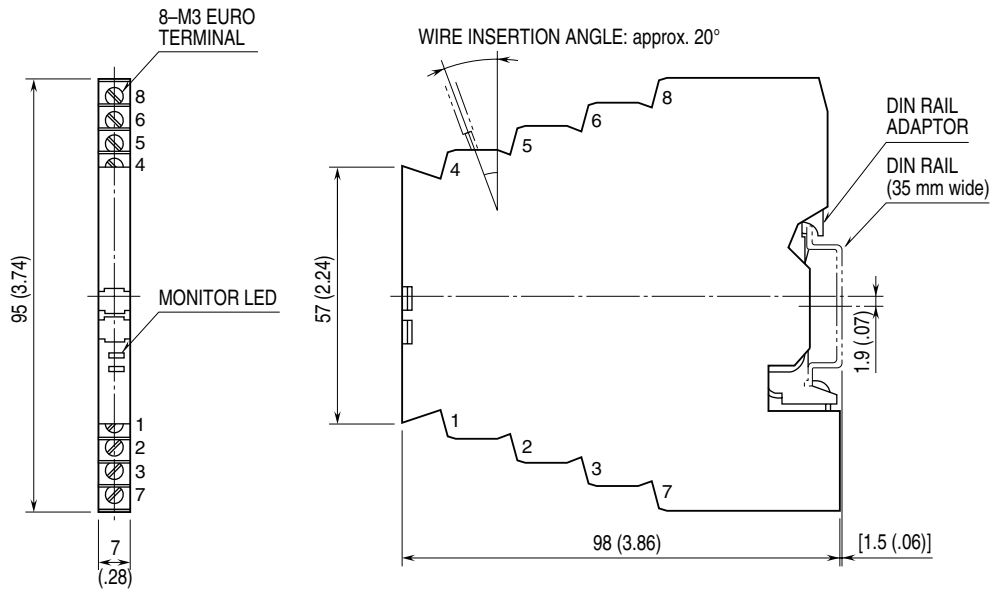

SCHEMATIC CIRCUITRY & CONNECTION DIAGRAM

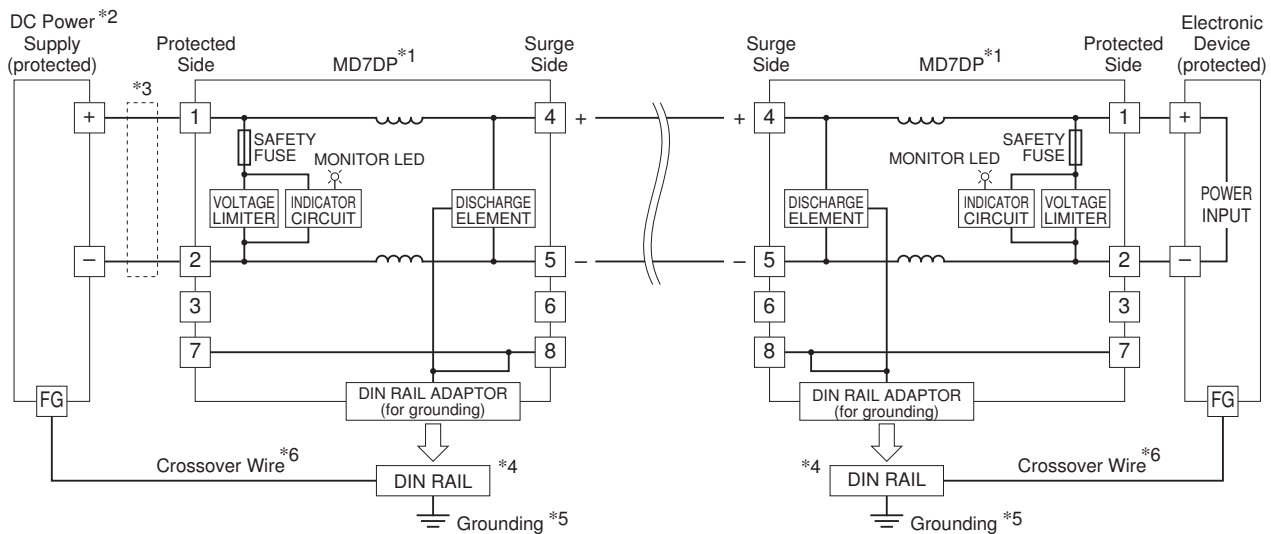

- *1. The MD7DP is not applicable to protect two-wire transmitters. To protect two-wire transmitters, model MD7ST designed to yield only small leakage current is suitable.
Confirm the polarity of the terminals when connecting this module to a protected device.
- *2. Use a DC power source with the overload current protection function. (maximum output current 1.2A)
- *3. Install a current limiting element (capacity 1.2A) when the output current exceeds 1.2A.
- *4. Oxide coating of an aluminium rail may lower the electric conductivity between this module and the ground.
Use a steel or copper rail.
- *5. Be sure to ground the DIN rail. Recommended grounding resistance ≤ 100
- *6. Cross-wire between the DIN rail and the metal housing of the protected device to equalize the earth potential.
Ground only the surge protector when the protected device has no ground terminal.



Specifications are subject to change without notice.