

Power Transducer Series LT-UNIT

AC CURRENT TRANSDUCER

(clamp-on current sensor; RMS sensing)

Functions & Features

- Converts an alternating current into a standard process signal
- Easy-to-install clamp-on type current sensor without needing a current transformer
- Clamp-on current sensor included
- Wide input range from 10 A up to 600 A
- Input frequency 50 / 60 / 400 Hz
- Over-voltage clamp element for safety in open circuit
- High-density mounting

Typical Applications

- Centralized monitoring and control of motors at a supervisory panel
- Monitoring abnormal load current at motors to detect pump malfunctions

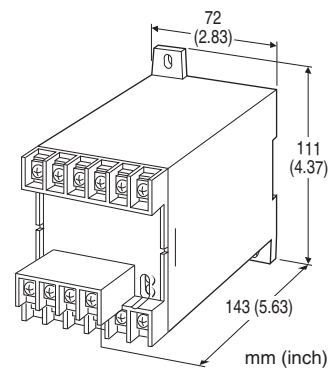

MODEL: LTCEC-[1][2][3]-[4][5]

ORDERING INFORMATION

- Code number: LTCEC-[1][2][3]-[4][5]
- Specify a code from below for each of [1] through [5].
(e.g. LTCEC-150A-B/T/Q)
- Special output range (For codes Z & 0)
- Specify the specification for option code /Q
(e.g. /C01)

[1] SENSOR

- 1: Leadwire type CLSA
- 2: Screw terminal type CLSB

[2] INPUT

- 10: 0 - 10 A AC
- 15: 0 - 15 A AC
- 20: 0 - 20 A AC
- 30: 0 - 30 A AC
- 40: 0 - 40 A AC
- 50: 0 - 50 A AC
- 60: 0 - 60 A AC
- 75: 0 - 75 A AC
- 100: 0 - 100 A AC
- 125: 0 - 125 A AC
- 150: 0 - 150 A AC
- 175: 0 - 175 A AC
- 200: 0 - 200 A AC
- 225: 0 - 225 A AC
- 250: 0 - 250 A AC
- 300: 0 - 300 A AC
- 350: 0 - 350 A AC
- 400: 0 - 400 A AC
- 500: 0 - 500 A AC
- 600: 0 - 600 A AC (Not selectable with the sensor type code 1 'Leadwire type CLSA')

[3] OUTPUT

Current

- A: 4 - 20 mA DC (Load resistance 500 Ω max.)
- D: 0 - 20 mA DC (Load resistance 500 Ω max.)
- F: 0 - 10 mA DC (Load resistance 1000 Ω max.)
- G: 0 - 1 mA DC (Load resistance 10 kΩ max.)
- J: 0 - 5 mA DC (Load resistance 2000 Ω max.)
- Z: Specify current (See OUTPUT SPECIFICATIONS)

Voltage

- 1: 0 - 10 mV DC (Load resistance 10 kΩ min.)
- 2: 0 - 100 mV DC (Load resistance 100 kΩ min.)
- 3: 0 - 1 V DC (Load resistance 1000 Ω min.)
- 4: 0 - 10 V DC (Load resistance 10 kΩ min.)
- 5: 0 - 5 V DC (Load resistance 5000 Ω min.)
- 6: 1 - 5 V DC (Load resistance 5000 Ω min.)
- 0: Specify voltage (See OUTPUT SPECIFICATIONS)

[4] AUXILIARY POWER SUPPLY

AC Power

- B: 100 V AC
- C: 110 V AC
- D: 115 V AC
- F: 120 V AC
- G: 200 V AC
- H: 220 V AC
- J: 240 V AC

DC Power

- R: 24 V DC

V: 48 V DC
P: 110 V DC

[5] OPTIONS (multiple selections)

Terminal Cover

blank: Without

/T: With

Other Options

blank: none

/Q: Option other than the above (specify the specification)

SPECIFICATIONS OF OPTION: Q

COATING (For the detail, refer to M-System's web site.)

/C01: Silicone coating

/C02: Polyurethane coating

/C03: Rubber coating

ACCESSORIES

The clamp-on current sensor is included in the product package.

■ CLAMP-ON CURRENT SENSOR (leadwire type CLSA)

- 0 – 10 A through 0 – 75 A Use

Sensor model No.: CLSA-08

Sensor cable model No.: CLSA-08C-30

Applicable cable diameter: Max. 10.0

Sensor leadwire: AWG 22

Weight: 45 g (1.6 oz)

- 0 – 100 A Use

Sensor model No.: CLSA-12

Sensor cable model No.: CLSA-08C-30

Applicable cable diameter: Max. 16.0

Sensor leadwire: AWG 22

Weight: 70 g (2.5 oz)

- 0 – 125 A through 0 – 300 A Use

Sensor model No.: CLSA-30

Applicable cable diameter: Max. 24.0

Sensor leadwire: AWG 18, 200 mm

Weight: 200 g (7.1 oz)

- 0 – 350 A through 0 – 500 A Use

Sensor model No.: CLSA-50

Applicable cable diameter: Max. 36.0

Sensor leadwire: AWG 18, 200 mm

Weight: 300 g (10.6 oz)

■ CLAMP-ON CURRENT SENSOR (screw terminal type CLSB)

Connection: M3 screw terminal (torque 0.5 N·m)

Screw terminal: Nickel-plated steel

Output wiring: Use AWG22 or thicker wires for the output.

Twist the paired wires, extendable up to 30 meters.

- 0 – 10 A through 0 – 50 A Use

Sensor model No.: CLSB-05

Applicable cable diameter: Max. 10.0

Weight: 45 g (1.6 oz)

- 0 – 60 A through 0 – 100 A Use

Sensor model No.: CLSB-10

Applicable cable diameter: Max. 16.0

Weight: 80 g (2.8 oz)

- 0 – 125 A through 0 – 200 A Use

Sensor model No.: CLSB-20

Applicable cable diameter: Max. 24.0

Weight: 200 g (7.1 oz)

- 0 – 225 A through 0 – 400 A Use

Sensor model No.: CLSB-40

Applicable cable diameter: Max. 35.0

Weight: 300 g (10.6 oz)

- 0 – 500 A through 0 – 600 A Use

Sensor model No.: CLSB-60

Applicable cable diameter: Max. 35.0

Weight: 360 g (12.7 oz)

Note 1: The output values may vary depending on the accuracy of engagement at the clamp connection.

Note 2: The sensor is detachable up to 100 times (approx.).

Note 3: The sensor's mechanical construction may cause it to generate resonance sound. However, it does not affect the performance of the sensor.

GENERAL SPECIFICATIONS

Connection: M4 screw terminals (torque 1.2 N·m)

Screw terminal: Chrome-plated steel

Housing material: Flame-resistant resin (black)

Isolation: Sensor core to sensor output or input to output to auxiliary power

Input waveform: Up to 15 % of 3rd harmonic content

Overrange output: 0 to 120 % at 1 – 5 V

Zero adjustment: -5 to +5 % (front)

Span adjustment: 95 to 105 % (front)

INPUT SPECIFICATIONS

Frequency: 50 / 60 / 400 Hz

Overload capacity

CLSA-08: 120 A continuous

CLSA-12: 300 A continuous

CLSA-30: 360 A continuous

CLSA-50: 600 A continuous

CLSB-05: 100 A continuous

CLSB-10: 200 A continuous

CLSB-20: 300 A continuous

CLSB-40: 600 A continuous

CLSB-60: 720 A continuous

Operational range: 0 – 120 % of rating

Note: Be sure that the input voltage is of 440 V or less.

OUTPUT SPECIFICATIONS

■ **DC Current:** 0 – 20 mA DC

Minimum span: 1 mA

Offset: Max. 1.5 times span

Load resistance: Output drive 10 V max.

■ **DC Voltage:** 0 – 12 V DC

Minimum span: 5 mV

Offset: Max. 1.5 times span

Load resistance: Output drive 1 mA max.; at ≥ 0.5 V

• **Operation Diagram (example)**

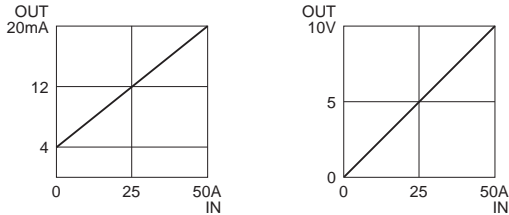

INSTALLATION

Auxiliary Power

• **AC:** Operational voltage range: rating $-15/+10$ %, 50/60 Hz, approx. 3 VA

• **DC:** Operational voltage range for R, V: Rating ± 10 % or P: 85 – 150 V; ripple 10 %p-p max. approx. 1.7 W (15 mA at 110 V)

Operating temperature: -10 to $+55^{\circ}\text{C}$ (14 to 131°F)

Operating humidity: 30 to 85 %RH (non-condensing)

Mounting: Surface or DIN rail

Weight: 450 g (0.99 lb)

PERFORMANCE in percentage of span

Accuracy: ± 0.5 % (± 1.0 % at 400 Hz) at $23^{\circ}\text{C} \pm 10^{\circ}\text{C}$ or $73.4^{\circ}\text{F} \pm 18^{\circ}\text{F}$, 45 – 65 Hz

Magnetic field (ext. origin) effect: ± 0.5 % (400 A/m)

Response time: ≤ 1 sec. (0 – 100 % ± 1 %)

Ripple: 0.5 %p-p max.

Line voltage effect: ± 0.25 % over voltage range

Insulation resistance: ≥ 100 M Ω with 500 V DC (input to output to auxiliary power)

≥ 100 M Ω with 500 V DC

(sensor core to sensor output)

Dielectric strength: 2000 V AC @ 1 minute

(input to output to auxiliary power to ground)

1000 V AC @ 1 minute

(sensor core to sensor output)

Impulse withstand voltage: 1.2 / 50 $\mu\text{sec.}$, ± 5 kV

(input to output or ground)

CONNECTION DIAGRAM

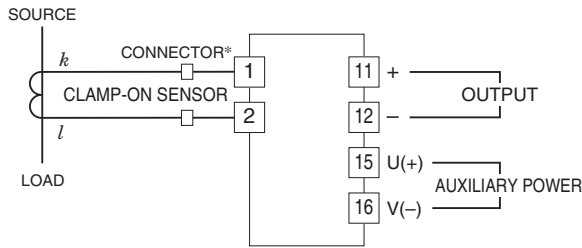

*Connector provided only for the CLSA-08 and CLSA-12.

EXTERNAL DIMENSIONS & TERMINAL ASSIGNMENTS unit: mm (inch)

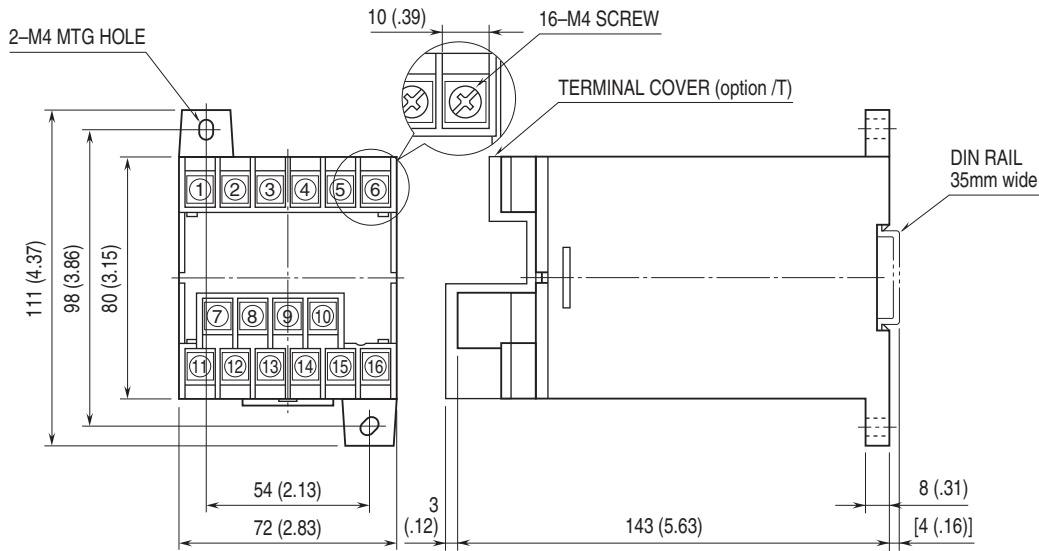

■ Sensor model No.: CLSA-08

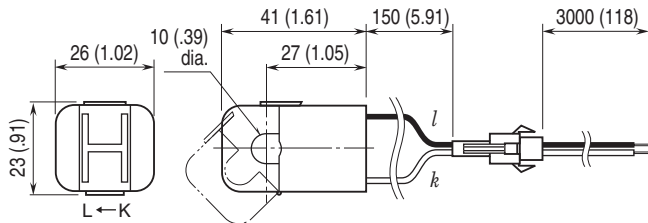

■ Sensor model No.: CLSA-30

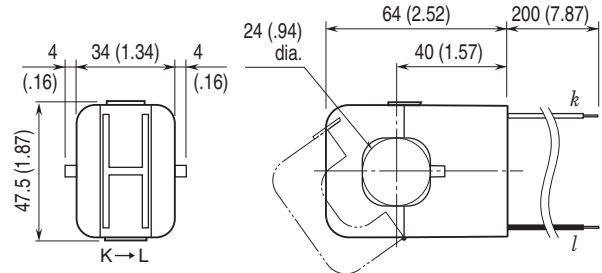

■ Sensor model No.: CLSA-12

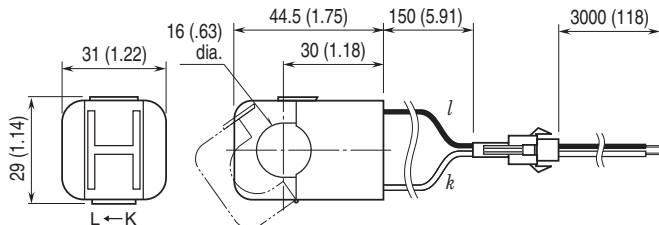

■ Sensor model No.: CLSA-50

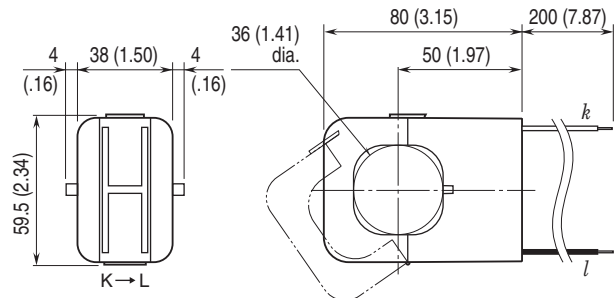

■ Sensor model No.: CLSB-05

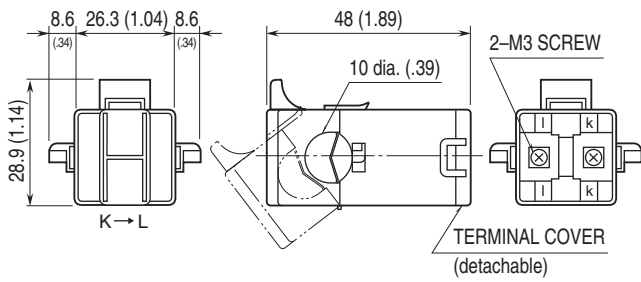

■ Sensor model No.: CLSB-10

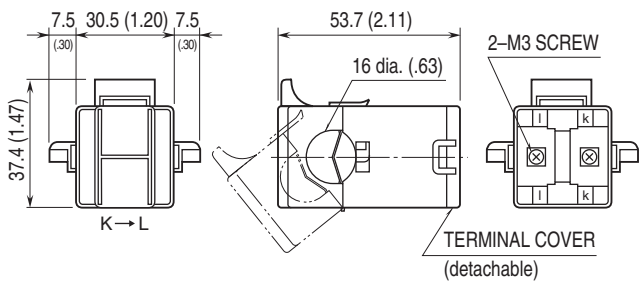

■ Sensor model No.: CLSB-20

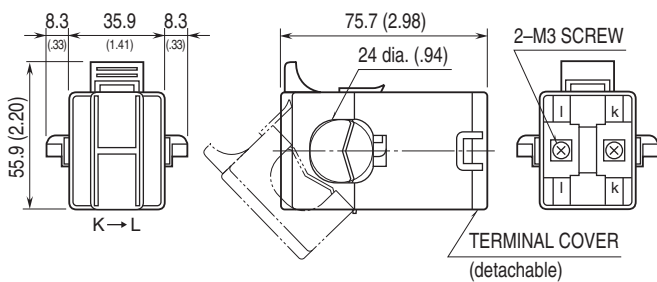

■ Sensor model No.: CLSB-40

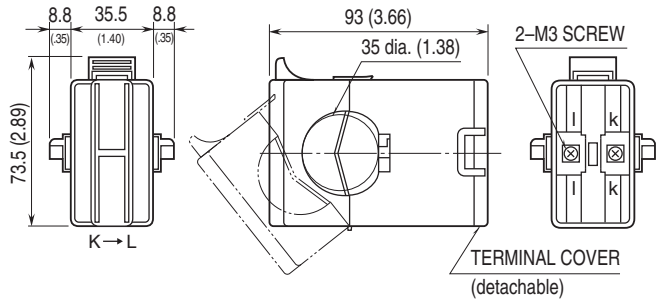

■ Sensor model No.: CLSB-60

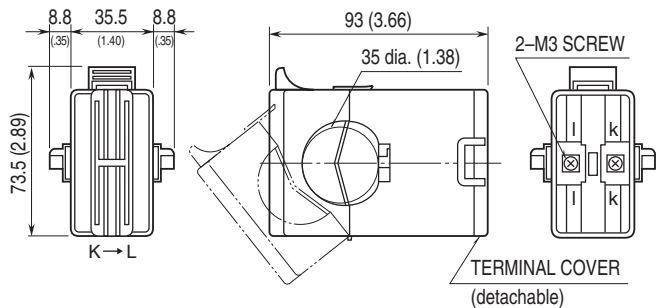



Specifications are subject to change without notice.