

Plug-in Signal Conditioners M-UNIT

ENCODER POSITION TRANSMITTER

(field-programmable; built-in excitation)

Functions & Features

- Converts a two-phase forward and reverse rotation pulse signal with 90 degree phase difference into a forward and reverse position signal
- Built-in excitation
- Field-selectable input type and range
- Isolation up to 2000 V AC
- High-density mounting

Typical Applications

- Measuring moving distance of a machine with a rotary encoder

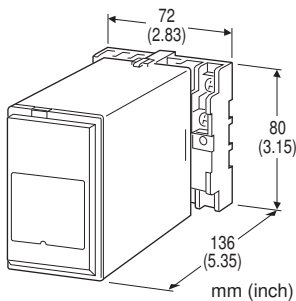

MODEL: JRQ2-[1][2]-[3][4]

ORDERING INFORMATION

- Code number: JRQ2-[1][2]-[3][4]
- Specify a code from below for each of [1] through [4]. (e.g. JRQ2-76-K/Q)
- Special output range (For codes Z & 0)
- Use Ordering Information Sheet (No. ESU-1576). Factory setting (table below) will be used if not otherwise specified.
- Specify the specification for option code /Q (e.g. /C01/S01)

Factory Setting

Input type	Open collector
Pulse amplitude	----
Noise filter	None
Detecting level	1V * (5V excitation) 2V * (12/24V excitation)
Count mode	1 count / 1 pulse (Phase B by one pulse edge)
Input zero count	0
Input span count	1000
Alarm setpoint	100%
Alarm deadband	1.00%
Alarm mode	High alarm
Linearization	Without
Input count at power off	Not held (Cold Start)

* Detecting voltage in the internal circuit

INPUT - Field-selectable

Open collector
Voltage pulse
RS-422 line driver pulse
Two inputs (phase A and B) are required for adequate operation of the this unit.

[1] EXCITATION

- 1: 5 V DC @ 120 mA
- 4: 12 V DC @ 60 mA
- 7: 24 V DC @ 25 mA

[2] OUTPUT

Current

- A: 4 - 20 mA DC (Load resistance 750 Ω max.)
- B: 2 - 10 mA DC (Load resistance 1500 Ω max.)
- C: 1 - 5 mA DC (Load resistance 3000 Ω max.)
- D: 0 - 20 mA DC (Load resistance 750 Ω max.)
- E: 0 - 16 mA DC (Load resistance 900 Ω max.)
- F: 0 - 10 mA DC (Load resistance 1500 Ω max.)
- G: 0 - 1 mA DC (Load resistance 15 kΩ max.)
- Z: Specify current (See OUTPUT SPECIFICATIONS)

Voltage

- 1: 0 - 10 mV DC (Load resistance 10 kΩ min.)
- 2: 0 - 100 mV DC (Load resistance 100 kΩ min.)
- 3: 0 - 1 V DC (Load resistance 100 Ω min.)
- 4: 0 - 10 V DC (Load resistance 1000 Ω min.)
- 5: 0 - 5 V DC (Load resistance 500 Ω min.)
- 6: 1 - 5 V DC (Load resistance 500 Ω min.)
- 4W: -10 - +10 V DC (Load resistance 2000 Ω min.)
- 5W: -5 - +5 V DC (Load resistance 1000 Ω min.)
- 0: Specify voltage (See OUTPUT SPECIFICATIONS)

[3] POWER INPUT

AC Power

K: 85 - 132 V AC

DC Power

- S: 12 V DC
- R: 24 V DC
- V: 48 V DC
- P: 110 V DC

[4] OPTIONS

blank: none
/Q: With options (specify the specification)

SPECIFICATIONS OF OPTION: Q (multiple selections)

COATING (For the detail, refer to M-System's web site.)

/C01: Silicone coating

/C02: Polyurethane coating

/C03: Rubber coating

TERMINAL SCREW MATERIAL

/S01: Stainless steel

RELATED PRODUCTS

- Programming Unit (model: PU-2x)
- PC configurator software (model: JXCON)

Downloadable at M-System's web site.

A dedicated cable is required to connect the module to the PC. Please refer to the internet software download site or the users manual for the PC configurator for applicable cable types.

GENERAL SPECIFICATIONS

Construction: Plug-in

Connection: M3.5 screw terminals

Screw terminal: Chromated steel (standard) or stainless steel

Housing material: Flame-resistant resin (black)

Isolation: Input to DC output to alarm output to power

Overrange output: Approx. -15 to +115 % at 1 - 5 V

Zero adjustment: -5 to +5 % (front)

Span adjustment: 95 to 105 % (front)

Alarm mode: High or Low

Alarm setpoint: -15 - +115 %

Alarm deadband: 0 - 20 %

Input monitor (PL1): Red LED blinks according to the input phase A.

Input monitor (PL2): Red LED blinks according to the input phase B.

Excitation adjustment: 5 - 24 V DC

Software programming: Programming Unit (model: PU-2x); (Refer to the users manual of JXCON for the adjustments configurable with JXCON)

- Input count range
- Zero and span adjustment
- Linearization
- Alarm setpoint
- Output fine adjustment
- Others

Adjustments: With DIP and Rotary switches.

- Input Type
- Noise Filter
- Pulse amplitude

(Refer to the instruction manual for details)

Modular jack: Connecting the PU-2x

Input pulse sensing: DC coupled

Reset input: Resets the internal counter value (The transmitter output equivalent to 0 count when the reset input terminals are closed for 500 msec. or longer.)

Output at input/zero/span count overflow

• **Positive side:** Held at the max. of 115 %

• **Negative side:** Held at the min. of -15 %

INPUT SPECIFICATIONS

Excitation: Shortcircuit protection; approx. 440 mA (max.) at shortcircuit

Maximum frequency: 200 kHz

Maximum count range: -99999999 to +99999999

Minimum pulse width time requirement: 2.5 μ sec. for both ON and OFF

■ Open Collector

Input requirements (Excitation: Sensing)

5 V: Approx. 4 V / 1.0 mA

12 V: Approx. 9 V / 2.3 mA

24 V: Approx. 16 V / 4.7 mA

ON resistance: $\leq 200 \Omega$

OFF resistance: $\geq 200 \text{ k}\Omega$

Detecting level:

1 V (5 V excitation)

2 V (12/24 V excitation)

(Detecting voltage in the internal circuit. For open collector input, be sure to re-adjust the voltage back to 1 V (5 V excitation) or 2 V (12/24 V excitation) if it has been changed for other input types.)

Detecting pulse edge: OFF (input monitor LED ON) to ON (LED OFF)

■ Voltage Pulse

Waveform: Square or sine

Input impedance: 10 k Ω min.

Pulse amplitude: 0.1 - 100 V_{p-p}

Max. voltage between input terminals: 50 V

Detecting level: 0 - 5 V

(Detecting voltage in the internal circuit.)

Detecting pulse state: A pulse rise detected when the input voltage goes above the detecting level (input monitor LED ON); a pulse sink detected when it goes below the level (LED OFF).

■ RS-422 Line Driver Pulse

Receiver: Conforms to RS-422

■ Reset Input

Sensing voltage: 4.5 V DC

Detecting level

ON: $\leq 1 \text{ V}$

OFF: $\geq 4 \text{ V}$

■ Voltage pulse waveform

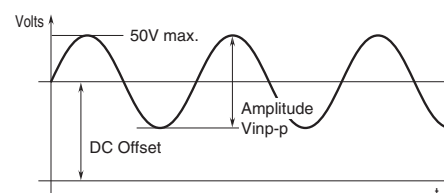

OUTPUT SPECIFICATIONS

■ **DC Current:** 0 – 20 mA DC

Minimum span: 1 mA

Offset: Max. 1.5 times span

Load resistance: Output drive 15 V max.

■ **DC Voltage:** -10 – +12 V DC

Minimum span: 5 mV

Offset: Max. 1.5 times span

Load resistance: Output drive 10 mA max.; 5 mA for negative voltage output; at ≥ 0.5 V

■ **Alarm Output:** Relay contact

Rated load: 125 V AC @ 0.5 A ($\cos \phi = 1$)

30 V DC @ 0.5 A (resistive load)

Maximum switching voltage: 250 V AC or 125 V DC

Maximum switching power: 62.5 VA or 60 W

Minimum load: 10 mV DC @ 1 mA

Mechanical life: 5×10^7 cycles (300 cycles/minute)

For maximum relay life with inductive loads, external protection is recommended.

INSTALLATION**Power input**

• **AC:** Operational voltage range 85 – 132 V,
47 – 66 Hz, approx. 7 VA

• **DC:** Operational voltage range: Rating ± 10 %, or 85 – 150 V for 110 V rating; ripple 10 %p-p max.; Approx. 4 W (140 mA at 24 V)

Operating temperature: -5 to +60°C (23 to 140°F)

Operating humidity: 30 to 90 %RH (non-condensing)

Mounting: Surface or DIN rail

Weight: 350 g (0.77 lb)

PERFORMANCE in percentage of span

Accuracy: ± 0.1 %

Alarm setpoint accuracy: ± 0.1 %

Temp. coefficient: ± 0.015 %/°C (± 0.008 %/°F)

Response time: ≤ 0.5 sec. (0 – 90 %)

Line voltage effect: ± 0.1 % over voltage range

Insulation resistance: ≥ 100 M Ω with 500 V DC

Dielectric strength:

2000 V AC @ 1 minute (input to output to power)

1500 V AC @ 1 minute (input or output or power to alarm output)

2000 V AC @ 1 minute (circuit to ground)

EXTERNAL VIEW

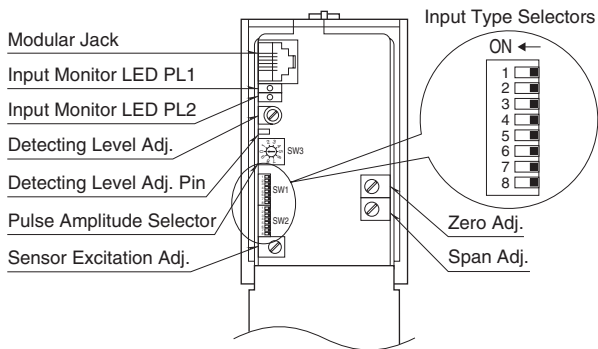

Refer to the instruction manual for detailed procedures.

OPERATION

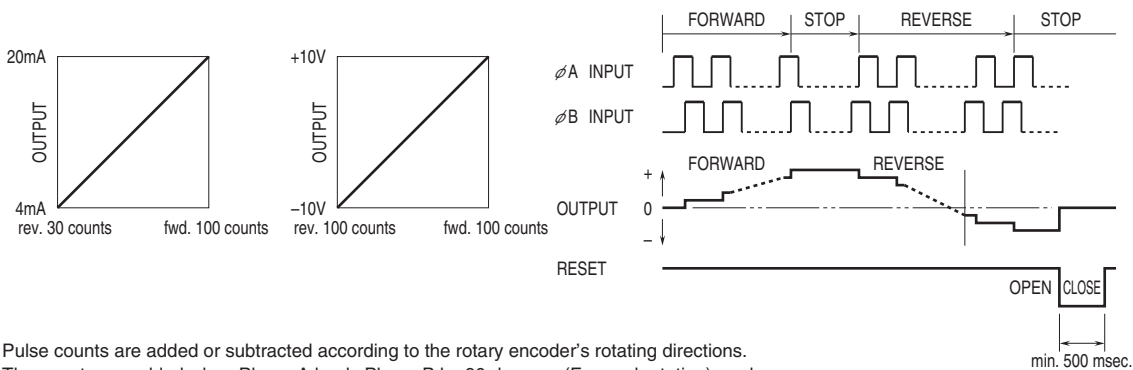

Pulse counts are added or subtracted according to the rotary encoder's rotating directions. The counts are added when Phase A leads Phase B by 90 degrees (Forward rotation), and subtracted when Phase A lags behind Phase B by 90 degrees (Reverse rotation).

EXTERNAL DIMENSIONS & TERMINAL ASSIGNMENTS unit: mm (inch)

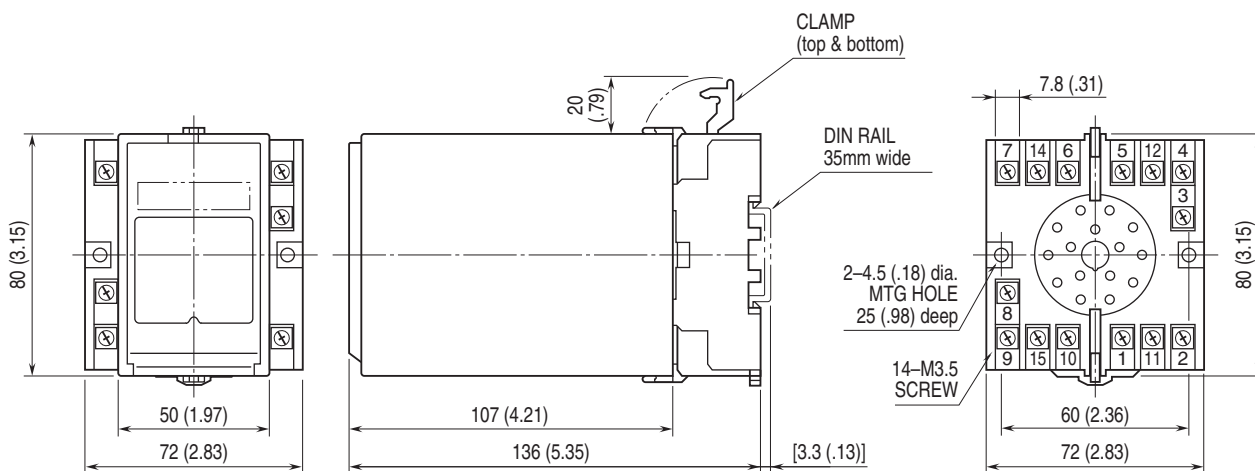

• When mounting, no extra space is needed between units.

SCHEMATIC CIRCUITRY & CONNECTION DIAGRAM

■ OPEN COLLECTOR or VOLTAGE PULSE INPUT

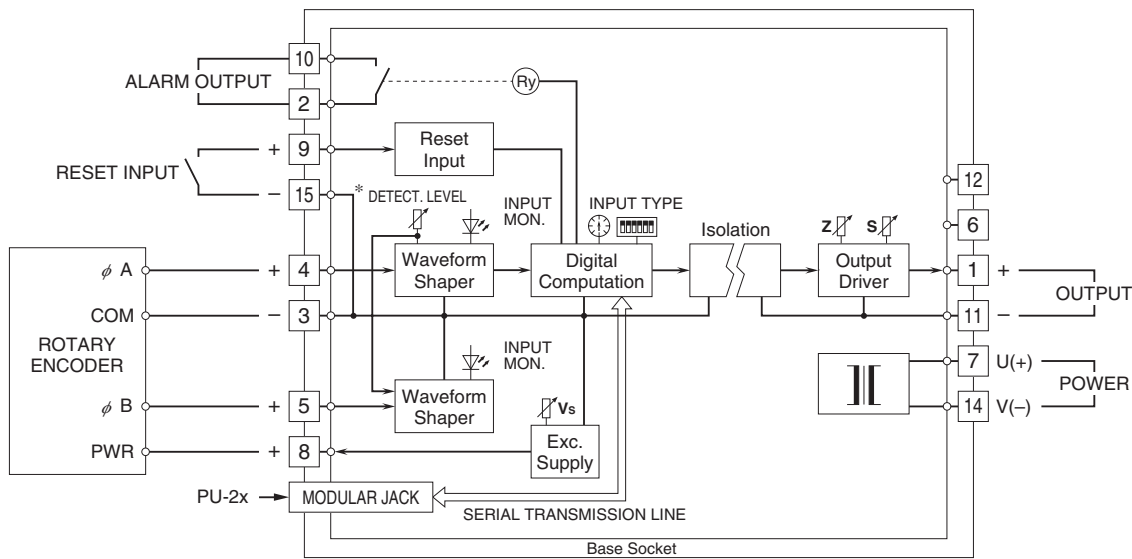

■ RS-422 LINE DRIVER INPUT

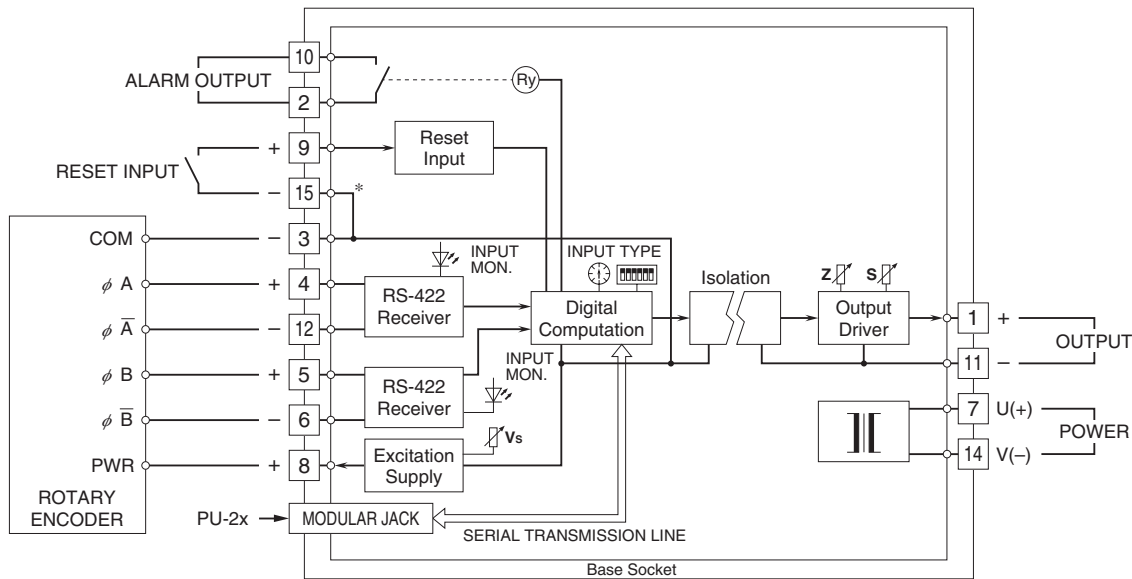

*Terminals 3 and 15 are internally connected.
COM terminals of the rotary encoder and the reset input can be connected to either one.



Specifications are subject to change without notice.