

## Field-mounted Two-wire Signal Conditioners 6-UNIT

### 4-DIGIT LOOP POWERED INDICATOR

(intrinsically safe)

#### Functions & Features

- 4-digit LED display
- No external power source needed
- Scaling, linearization and other configurations selectable via three front control buttons
- Mountable on top of the Two-wire Universal Temperature Transmitter (model: 27HU)

Note: Differences between the 6DV and the 6DVI exist only in safety parameters. Refer to the relevant section for more information.

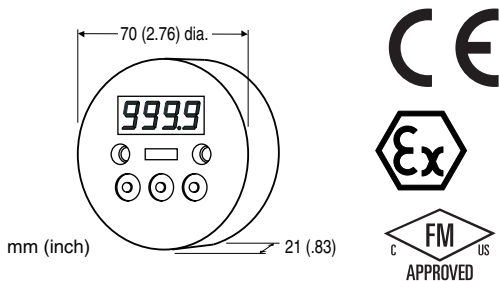

### MODEL: 6DV-[1]

#### ORDERING INFORMATION

- Code number: 6DV-[1]
- Specify a code from below for [1].  
(e.g. 6DV-0)
- Use Ordering Information Sheet (No. ESU-4221). Factory standard setting will be used if not otherwise specified.
  - Specify the country in which the product is to be used with the Safety Approval code 2.

#### [1] SAFETY APPROVAL

- 0: None
- 1: FM intrinsically safe
- 2: ATEX intrinsic safety
- 7: TIIS intrinsic safety (CE not available)

#### RELATED PRODUCTS

- DIN rail mounting adaptor (model: A-34)
- Mounting spacer (model: A-6)

#### GENERAL SPECIFICATIONS

- Connection:** Euro terminal
- Applicable wire size:** 0.14 - 1.5 mm<sup>2</sup> (AWG26 - 16), stripped length 6 mm
- Housing material:** Flame-resistant resin (black)
- Linearization:** Proportional, SQRT ( $X^{1/2}$ ), RT32 ( $X^{3/2}$ ), RT52 ( $X^{5/2}$ ), user's linearization table (max. 21 calibration points) (Default setting: Proportional)
- A/D conversion:** Dual-slope integration
- Security:** Protecting settings
- Scaling:** Programming via the front buttons

#### DISPLAY

- LED:** 8 mm (.3") 7-segment, red
- Number of display digits:** 4
- Scaling range:** -1999 to 9999 counts
- Offset range:** -1999 to 9999 counts
- Decimal point position:** 10<sup>-1</sup>, 10<sup>-2</sup>, 10<sup>-3</sup> or none
- Polarity sign:** Minus (-) sign added automatically according to the computation result
- Over-range warning:** All segments dark except the top ones that blink with the input exceeding the display/measurable range; or the bottom ones that blink with the input below the range.
- Read rate:** 2.5/s
- Engineering unit indication:** Sticker label attached  
DC, AC, W, °C, °F, V, mV, A, mA, %, kW, mW, kV, kA, psi, K, bar, barg, Nl/min, kvar, Mvar, var, m, mm, kg, kg/h, kPa, MPa, N·m, Nm<sup>3</sup>/h, m<sup>3</sup>/h, m<sup>3</sup>/sec, m/sec, kgf/cm<sup>2</sup>, l/min, %RH, l, l/h, t/h, rpm, ppm, pH, Pa

#### INPUT SPECIFICATIONS

- **DC Current:** 4 - 20 mA DC
- Measurable range:** 3.75 - 23 mA DC
- Maximum input current**
- Non-approved:** 100 mA
- Intrinsically safe:** Refer to 'Safety Parameters.'
- Voltage drop:** Approx. 3.7 V with 4 mA  
Approx. 4.0 V with 20 mA (Equivalent input impedance: Approx. 200 Ω)
- The minimum required supply voltage to the 2-wire transmitter added with the indicator's voltage drop at the maximum input current must be within the output voltage range of the 2-wire transmitter's excitation supply.

#### INSTALLATION

- Operating temperature:** -40 to +85°C (-40 to +185°F)  
(See Safety Parameters for use in a hazardous location.)
- Operating humidity:** 0 to 95 %RH (non-condensing)
- Weight:** 65 g (2.3 oz)

## PERFORMANCE

Accuracy:  $\pm 0.01$  mA

Temp. coefficient:  $\pm 0.015$  %/°C ( $\pm 0.008$  %/°F) at 4 - 20 mA input

## HOW TO CALCULATE ACCURACY AGAINST SCALE

Example 1: 4 - 20 mA input, Scale 0 - 100

Accuracy =  $0.01 \text{ mA} \div (20 - 4) \text{ mA} \times 100 = 0.063 \%$

Display Error =  $(100 - 0) \times 0.063 \% = \pm 0.063$  digits

Example 2: 10 - 20 mA input, Scale 100 - 1000

Accuracy =  $0.01 \text{ mA} \div (20 - 10) \text{ mA} \times 100 = 0.1 \%$

Display Error =  $(1000 - 100) \times 0.1 \% = \pm 0.9$  digits

## STANDARDS & APPROVALS

Refer to the manuals to comply with the standards.

### EU conformity:

ATEX Directive (for ATEX intrinsic safety)

Ex ia EN 60079-11

EMC Directive

EMI EN 61000-6-4

EMS EN 61000-6-2

RoHS Directive

EN 50581

### Safety approval:

FM: Intrinsically safe

Class I, Div. 1, Groups A, B, C and D

Class I, Zone 0, AEx ia IIC (US)

Class I, Zone 0, Ex ia IIC (Canada)

T4 and T5

(Class 3600)

(Class 3610)

(ANSI/ISA 60079-0)

(ANSI/ISA 60079-11)

(CAN/CSA-C22.2 E60079-0)

(CAN/CSA-C22.2 E60079-11)

TIIS: Intrinsic safety

Ex ia IIC T5

ATEX: Intrinsic safety

⊕ II 1G, Ex ia IIC; T4, T5, Ga

(EN 60079-0)

(EN 60079-11)

## SAFETY PARAMETERS

### Operating temperature

For ATEX / FM:

T4: -40 to +80°C

T5: -40 to +60°C

For TIIS:

T5: -20 to +60°C

### Ex-data:

Ui (Vmax): 30 V DC

Ii (Imax): 100 mA DC

Pi (Pmax): 0.75 W

Ci: 1.0 nF

Li: 0 mH (TIIS Intrinsically Safe: 'Negligible value')

## DISPLAY DESCRIPTIONS

### ■ DISPLAY DIGITS

The decimal point position may shift according to the required number of digits for the integer section, even when more than one decimal places have been specified.

However, when the number of decimal places is set to 3, the '0' in the integer section is not shown in order to secure the number of effective digits, as explained in the table below.

The '0' is displayed when the number of decimal places is set to 2, though the number of effective digits in this case is reduced by 1 digit compared from the 3 decimal places. Select appropriately for the application. Refer to 'Programming Procedure' for how to choose decimal point positions.

DECIMAL	VALUE	DATA DISPLAY
3	-1.000 thr . -1.999	<del>1000</del> ... <del>1999</del>
	-0.001 thr . -0.999	<del>001</del> ... <del>999</del>
2	-1.00 thr . -1.99	- 100 ... - 199
	-0.01 thr . -0.99	- 001 ... - 099

### ■ ERROR INDICATION

The data display blinks when an abnormality is detected.

The unit display backlight also blinks.

When the setting error or the security code error occurs, press ENTR / ESC button once to cancel the error status and proceed to set again.

ERROR TYPE	DATA DISPLAY
Over-scale	
Under-scale	
Setting error	
Security code error	

**EXTERNAL VIEW**

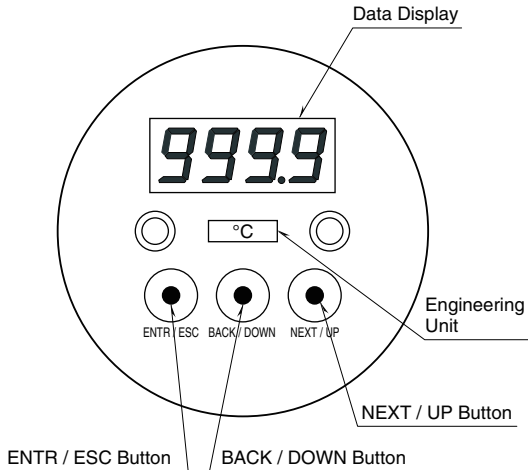

**EXTERNAL DIMENSIONS & TERMINAL ASSIGNMENTS unit: mm (inch)**

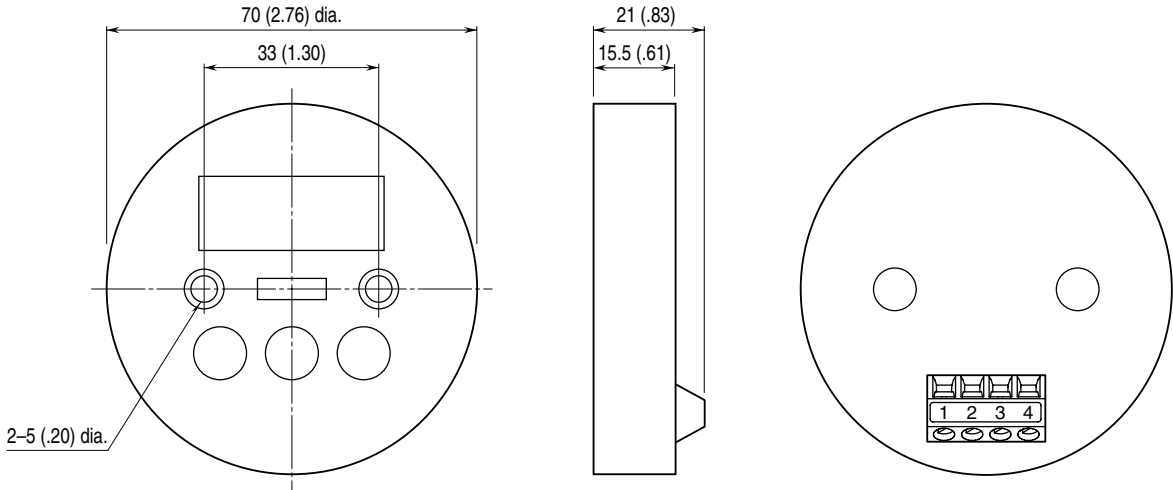

**MOUNTING REQUIREMENTS unit: mm (inch)**

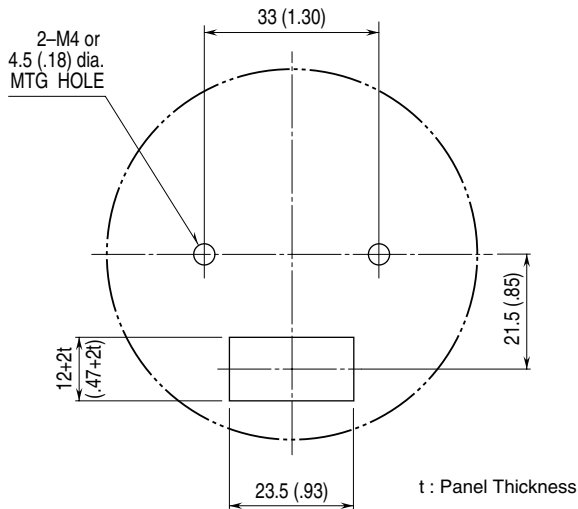

**CONNECTION DIAGRAM**

■ 2-WIRE CONNECTION EXAMPLE

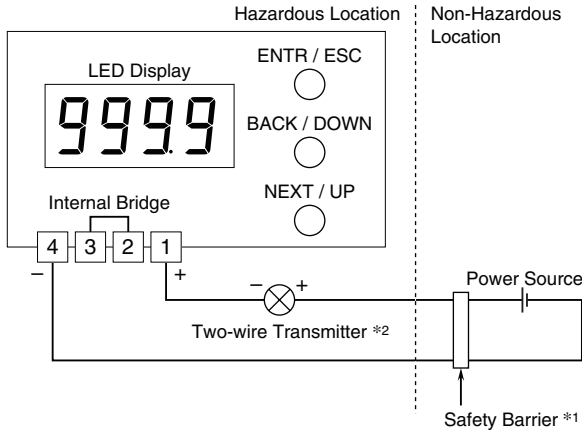

■ 4-WIRE CONNECTION EXAMPLE

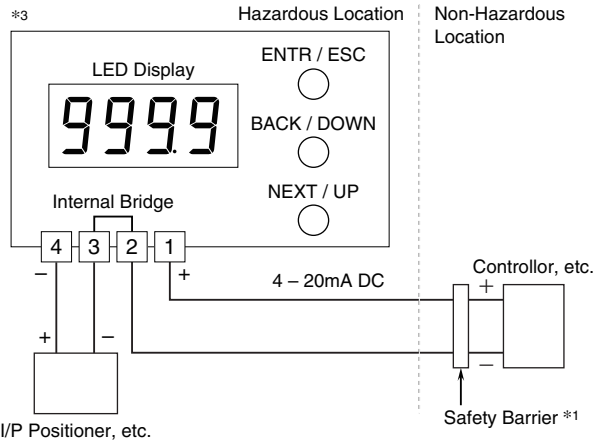
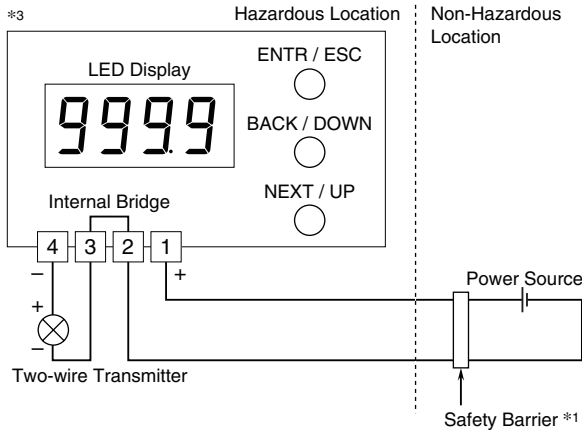
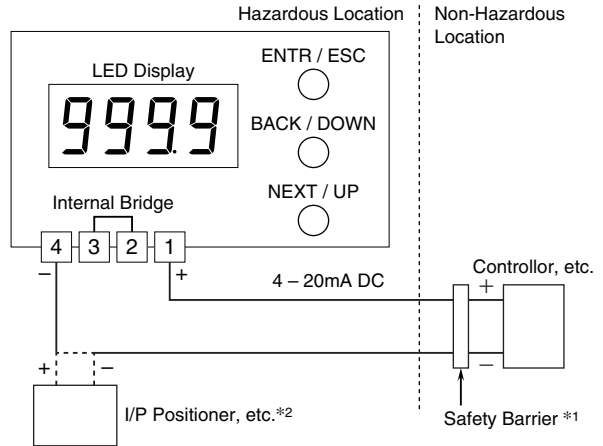

- \*1. A safety barrier must be installed for the intrinsic safety.  
The safety barrier must meet the Ex-data of this unit and must be approved for the hazardous location.
- \*2. In order to use a two-wire transmitter, etc. in the TIIS intrinsically safe circuit, the combination of the 6DV with the transmitter must be re-evaluated and approved by the TIIS.
- \*3. This connection diagram is not applicable for the TIIS intrinsic safety.



Specifications are subject to change without notice.