

Digital Panel Meters 47 Series

VT INPUT DIGITAL PANEL METER

(4½ digit, LED display type, true RMS sensing)

Functions & Features

- 4½ digit VT input digital panel meter
- 1/8 DIN size
- Moving average function to suppress the display flickering
- Max. and Min. value display
- IP66 front panel
- Separable terminal block
- Rear terminal cover for safety strapped to the meter

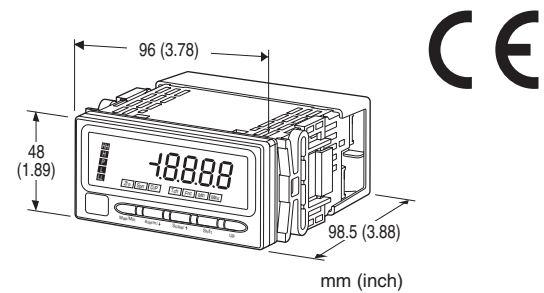

MODEL: 47LPT-1[1][2][3]-[4][5]

ORDERING INFORMATION

- Code number: 47LPT-1[1][2][3]-[4][5]
- Specify a code from below for each of [1] through [5].
(e.g. 47LPT-101G-M2/Q)
- Specify the specification for option code /Q
(e.g. /C01/S01/SET)

INPUT

1: AC voltage

[1] DC OUTPUT

0: Without

Current

A: 4 - 20 mA DC (Load resistance 550 Ω max.)

D: 0 - 20 mA DC (Load resistance 550 Ω max.)

Voltage

4: 0 - 10 V DC (Load resistance 10 kΩ min.)

5: 0 - 5 V DC (Load resistance 5000 Ω min.)

6: 1 - 5 V DC (Load resistance 5000 Ω min.)

4W: -10 - +10 V DC (Load resistance 10 kΩ min.)

[2] ALARM OUTPUT

0: None

1: N.O. relay contact, 4 points

2: SPDT relay contact, 2 points

[3] DISPLAY COLOR

R: Red

YR: Orange

G: Green

BG: Bluegreen

B: Blue

W: White

[4] POWER INPUT

AC Power

M2: 100 - 240 V AC (Operational voltage range 85 - 264 V, 50/60 Hz)

DC Power

R: 24 V DC

(Operational voltage range 24 V ±10 %, ripple 10 %p-p max.)

P: 110 V DC

(Operational voltage range 85 - 150 V, ripple 10 %p-p max.)

[5] OPTIONS

blank: none

/Q: With options (specify the specification)

SPECIFICATIONS OF OPTION: Q (multiple selections)

COATING (For the detail, refer to M-System's web site.)

Moving parts and indicators are not coated.

/C01: Silicone coating

/C02: Polyurethane coating

/C03: Rubber coating

TERMINAL SCREW MATERIAL

/S01: Stainless steel

EX-FACTORY SETTING

/SET: Preset according to the Ordering Information Sheet
(No. ESU-9506)

GENERAL SPECIFICATIONS

Construction: Panel flush mounting

Degree of protection: IP66; applicable to the front of the panel meter mounted according to the specified panel cutout

Connection: M3 separable screw terminal (torque 0.6 N·m)

Screw terminal: Nickel-plated steel (standard) or stainless steel

Housing material: Flame-resistant resin (gray)

Isolation: Input to DC output to HH output or H output to L output or LL output to power

Input waveform

RMS sensing: Up to 15 % of 3rd harmonic content

Setting: (Front button)

- Scaled range
- Input type
- Alarm setpoint

- Hysteresis (deadband)
- Moving average
- Others

(Refer to the instruction manual for details)

Read rate: 40 times/sec. (25 msec.)

Averaging: None or moving average

Lockout setting: Prohibiting certain operations; protecting settings

DISPLAY

Display: 16 mm (.63) high, 4 ½ digits, 7-segment LED

Display range: -19999 to 19999

Decimal point position: 10⁻¹, 10⁻², 10⁻³, 10⁻⁴ or none

Zero indication: Higher-digit zeros are suppressed.

Over-range indication: 'S.ERR' or '19999' blinking for display values out of the scaled range.

'S.ERR' and 'Max' blinking when the input signal is out of the usable range.

Alarm status indication

LL indicator: Green turns on when the LL alarm is tripped.

L indicator: Green turns on when the L alarm is tripped.

H indicator: Red turns on when the H alarm is tripped.

HH indicator: Red turns on when the HH alarm is tripped.

P indicator: Amber turns on when none of the other alarms is tripped.

Note: Only 'P' turns on with no-alarm-output type. 'LL' or 'HH' does not turn on with dual-alarm-output type.

All setpoints can be independently set either for Hi or Lo alarm trip.

Function indicators:

Zro, Spn, D/P, Tch, Fnc, Min, Max

Display mode status and operation status, amber ON or blink

Engineering unit indication:

DC, AC, mV, V, kV, μA, mA, A, kA, mW, W,

kW, var, kvar, Mvar, VA, Hz, Ω, kΩ, MΩ,

cm, mm, m, m/sec, mm/min, cm/min, m/min,

m/h, m/s², inch, l, l/s, l/min, l/h, m³, m³/sec,

m³/min, m³/h, Nm³/h, N·m, N/m², g, kg, kg/h,

N, kN, Pa, kPa, MPa, t, t/h, °C, °F, %RH, J,

kJ, MJ, rpm, sec, min, min⁻¹, pH, %, ppm, etc.

INPUT SPECIFICATIONS

Frequency: 50 or 60 Hz

Overload capacity: 450 V for 10 sec., 360 V continuous

Default measuring range: 0 - 300 V

TYPE IND	MEASURING RANGE	OPERATIONAL RANGE	INPUT BURDEN
V150	0 - 150V	0 - 165V	≤0.5VA
V300	0 - 300V	0 - 330V	≤0.5VA

OUTPUT SPECIFICATIONS

■ DC Output

- DC Current

Operational range: -5 - +105 %

- DC Voltage

Operational range: -5 - +105 %

■ Alarm Output: Relay contact

Rated load: 250 V AC @ 3 A (cos φ = 1)

30 V DC @ 3 A (resistive load)

Maximum switching voltage: 250 V AC, 30 V DC

Maximum switching power: 750 VA, 90 W (resistive load)

Minimum load: 5 V DC @ 10 mA

Mechanical life: ≥ 5 × 10⁶ cycles (rate 180 cycles/min.)

INSTALLATION

Power consumption

- AC: Approx. 6.5VA

- DC: Approx. 3 W

Operating temperature: -10 to +55°C (14 to 131°F)

Operating humidity: 30 to 90 %RH (non-condensing)

Mounting: Panel flush mounting

Weight: 300 g (0.66 lb)

PERFORMANCE

Accuracy

Display: ±0.5 % ±10 digits with input 5 - 100 %

Output: ±0.1 %

(DC output = display + output)

Temp. coefficient: ±0.015 %/°C (±0.008 %/°F)

Input resolution: Max. 16 bits

Output resolution: Max. 14 bits

Response time: ≤ 0.5 sec.

(alarm output: 0 - 100 % at 90 % setpoint)

≤ 0.5 sec. (DC output: 0 - 90 %)

Line voltage effect: ±0.1 % over voltage range

Insulation resistance: ≥ 100 MΩ with 500 V DC

Dielectric strength: 2000 V AC @ 1 minute (input to DC output to HH output or H output to L output or LL output to power to ground)

STANDARDS & APPROVALS

EU conformity:

EMC Directive

EMI EN 61000-6-4

EMS EN 61000-6-2

Low Voltage Directive

EN 61010-1

Measurement Category III (input)

Measurement Category II (alarm output)

Installation Category II (power)

Pollution Degree 2

Input to alarm output to power: Reinforced insulation
(300 V)

RoHS Directive

Protection against access to the terminal blocks:

Finger protection (VDE 0660-514)

EXTERNAL VIEW

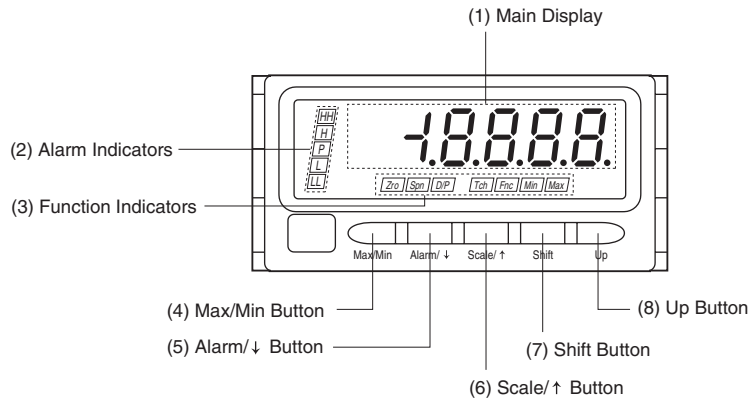

• COMPONENT IDENTIFICATION

No.	COMPONENT	FUNCTION
(1)	Main display	Indicates present values, setting values and status of the unit.
(2)	Alarm indicators	Indicate alarm status of the input signal.
(3)	Function indicators	Indicate the status in each setting mode.
(4)	Max/Min button	Used to switch the main display to show the present values, maximum values or minimum values etc.
(5)	Alarm/↓ button	Used to confirm alarm setting value and to move on to the alarm and other setting modes; or to shift through setting items in each setting mode.
(6)	Scale/↑ button	Used to move on to the scaling and other setting modes; or to shift through setting items in each setting mode.
(7)	Shift button	Used to move on to the setting standby status of each setting mode and shift through display digits in each setting mode.
(8)	Up button	Used to execute/cancel Forced Zero or to select setting values in each setting mode.

Note: Refer to the operating manual for details on each function.

EXTERNAL DIMENSIONS & TERMINAL ASSIGNMENTS unit: mm (inch)

■ TOP VIEW

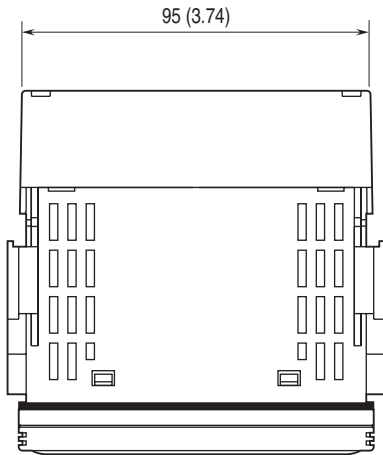

■ FRONT VIEW

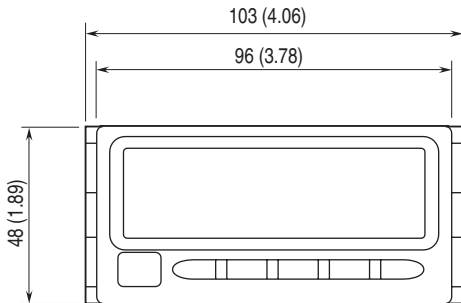

■ SIDE VIEW

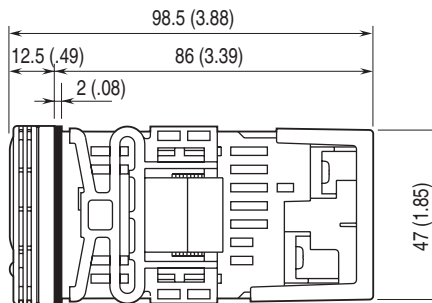

■ REAR VIEW

• No Alarm Output

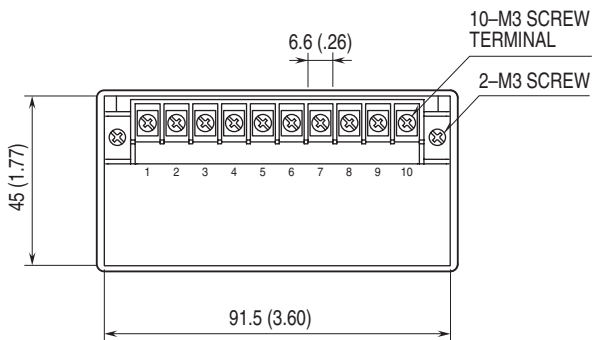

• Alarm Output

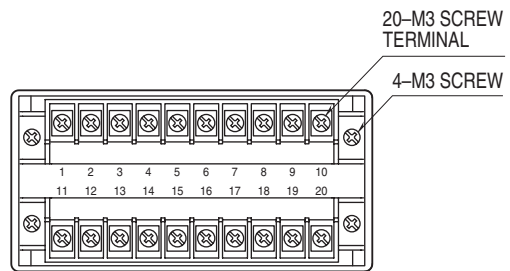

MOUNTING REQUIREMENTS unit: mm

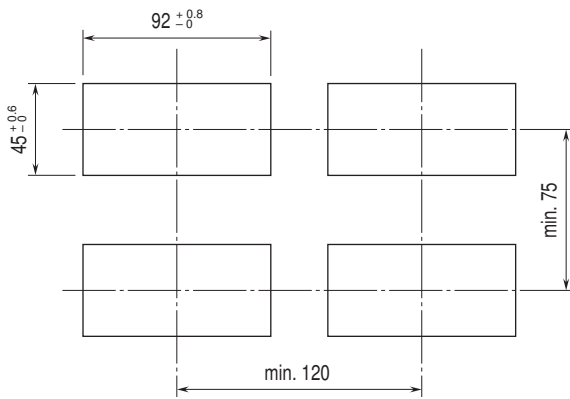

Panel thickness: 1.6 to 8.0 mm

SCHEMATIC CIRCUITRY & CONNECTION DIAGRAM

ALARM OUTPUT CODE 0: No alarm output

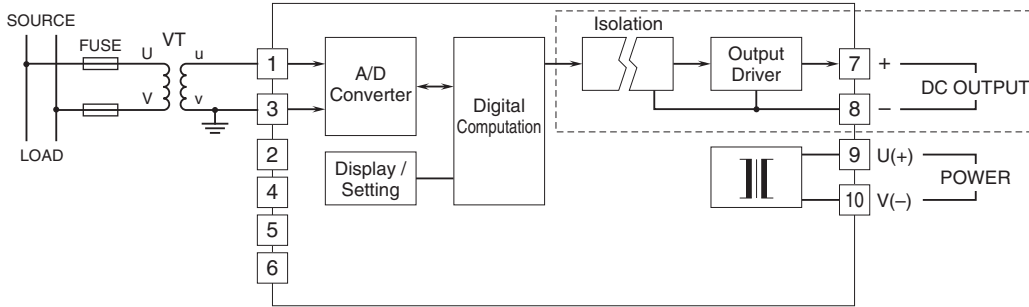

ALARM OUTPUT CODE 1: N.O. contact, 4 points

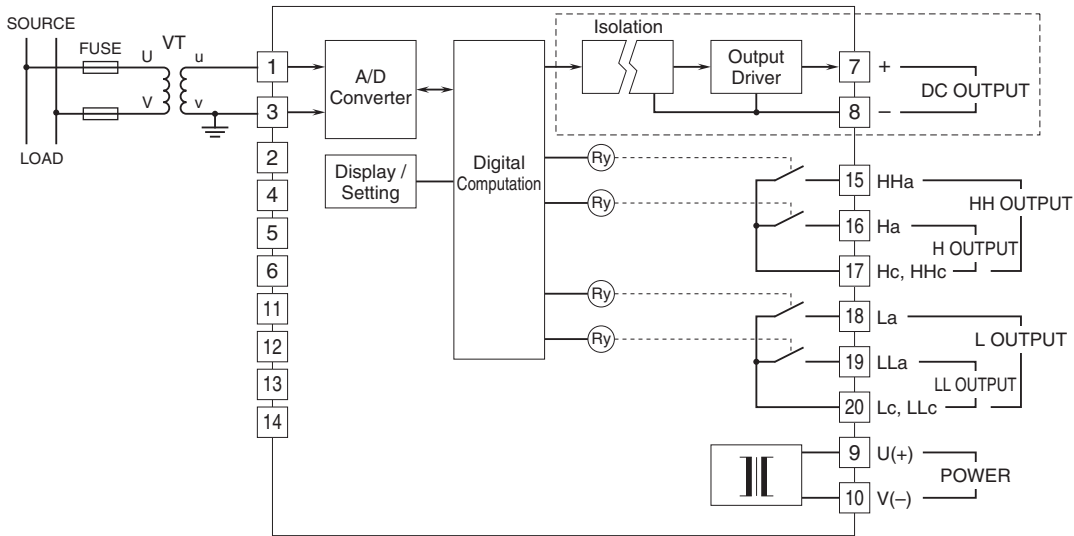

ALARM OUTPUT CODE 2: SPDT contact, 2 points

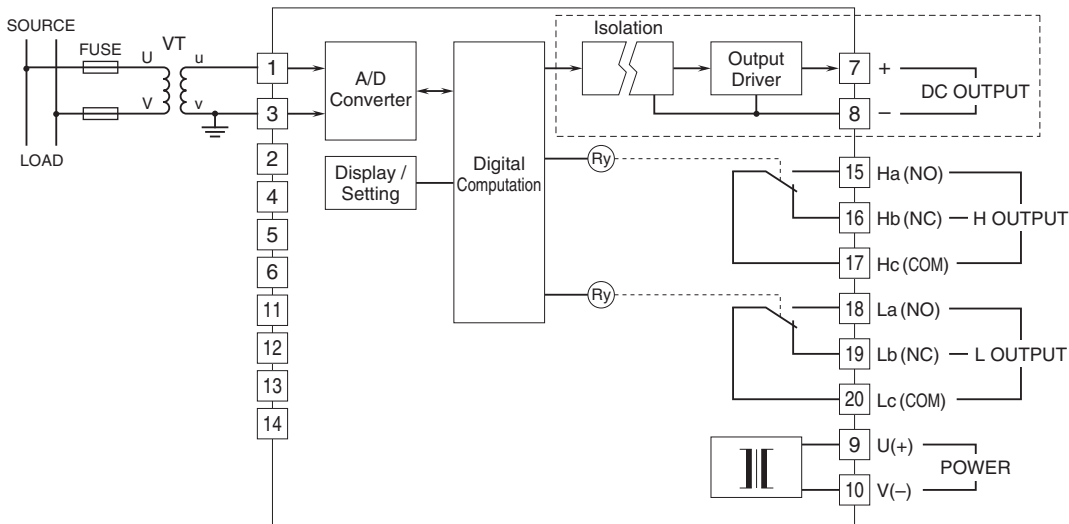

Note: The section enclosed by broken line is only with DC output option.

Relay Protection • AC Powered

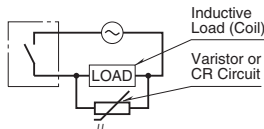

• DC Powered

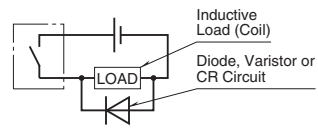



Specifications are subject to change without notice.