

Head-mounted Two-wire Signal Conditioners 27-UNIT

2-WIRE UNIVERSAL TEMPERATURE TRANSMITTER

(PC programmable)

Functions & Features

- Universal input: mV, T/C, RTD and resistance
- Suitable for Functional Safety applications up to SIL2
- Programming via PC Configurator
- A wide variety of T/C and RTD types
- User's temperature table can be used
- Self diagnostics
- Low temperature drift
- CE marking (conforms to ATEX and EMC)

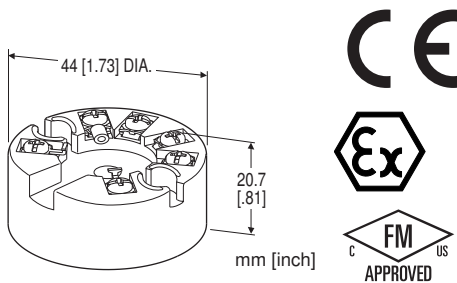

MODEL: 27U-[1]

ORDERING INFORMATION

- Code number: 27U-[1]

Specify a code from below for [1].

(e.g. 27U-0)

Use Ordering Information Sheet (No. ESU-7656). Factory standard setting will be used if not otherwise specified.

Specify the country in which the product is to be used with the Safety Approval code 2.

[1] SAFETY APPROVAL

0: None

1: FM intrinsically safe

2: ATEX intrinsic safety

RELATED PRODUCTS

- USB interface Bell202 modem (model: COP-HU)
Usable in 'non-hazardous' area only.
- PC configurator software (model: 27MCFG)
Downloadable at M-System's web site.

GENERAL SPECIFICATIONS

Construction: Sensor head-mounting

Connection: M3 screw terminals (torque 0.5 N·m)

Screw terminal: Nickel-plated brass

Housing material: Flame-resistant resin (black)

Isolation: Input to output

Cold Junction Compensation: CJC sensor incorporated

Self diagnostics: Detects internal error, burnout

User-configurable items: PC and the transmitter are connected with the COP-HU.

- Input sensor type
- Input range
- Burnout
- Output limits (Upper / Lower)
- Damping time (factory set to 0)
- Linearization
- Output calibration
- Loop test output

INPUT SPECIFICATIONS

The input is factory set for use with K thermocouple, single input, 0 to 100°C.

See Table 1 for the available input type, the minimum span and the maximum range.

■ DC mV

Input resistance: ≥ 1 MΩ

■ Thermocouple (dual input available)

Input resistance: ≥ 1 MΩ

■ RTD (2-wire, 3-wire or 4-wire)

Input resistance: ≥ 1 MΩ

Excitation: ≤ 0.25 mA

Allowable leadwire resistance: Max. 10 Ω per wire

■ Resistance (2-wire, 3-wire or 4-wire)

Input resistance: ≥ 1 MΩ

Excitation: 0.25 mA

Allowable leadwire resistance: Max. 10 Ω per wire

OUTPUT SPECIFICATIONS

Output range: 4 - 20 mA DC

Operational range: 3.75 - 23 mA

Load resistance vs. supply voltage:

Load Resistance (Ω) = (Supply Voltage (V) - 9 (V)) ÷ 0.023 (A) (including leadwire resistance)

Burnout: 3.75 - 3.8 mA or 21.5 - 23 mA

(factory set to 23 mA)

Upper output limit proportional to the input:

20 - 21.5 mA (factory set to 21.5 mA)

Lower output limit proportional to the input:

3.8 - 4 mA (factory set to 3.8 mA)

Update time: 440 msec. (660 msec. with dual input)

Output characteristics for dual input:

Average or Differential selectable

INSTALLATION

Supply voltage

- 9 - 35 V DC (non-approved)
- 9 - 28 V DC (approved)

Operating temperature: -40 to +85°C (-40 to +185°F)
(See Safety Parameters for use in a hazardous location.)

Operating humidity: 0 to 95 %RH (non-condensing)

Mounting: Head-mounting (DIN type B head)

Weight: 50 g (1.76 oz)

PERFORMANCE

Accuracy: As indicated in Table 1, ± 0.075 % of span or ± 0.075 % of max. range, whichever is the greatest.
Add the CJC error for T/C input.

(max. range = 0 % or 100 % value, absolute value of whichever is greater.)

Cold junction compensation error: $\pm 0.5^\circ\text{C}$ ($\pm 0.9^\circ\text{F}$)

Temp. coefficient: 0.0075 %/ $^\circ\text{C}$ (0.004 %/ $^\circ\text{F}$) of max. range
(max. range = 0 % or 100 % value, absolute value of whichever is greater.)

Response time: ≤ 1 sec. (0 - 90 %) or ≤ 2 sec. (4-wire RTD, 4-wire resistance or dual input T/C; 0 - 90 %) with damping time set to 0

Supply voltage effect: ± 0.01 % of span/V

Insulation resistance: ≥ 100 M Ω with 500 V DC

Dielectric strength: 1500 V AC @1 minute (input to output)

Safety integrity level according to IEC 61508: Suitable for use in a safety instrumented system up to SIL2 (together with sensor) if appropriate safety instructions are observed. Consult M-System.

STANDARDS & APPROVALS

EU conformity:

ATEX Directive

Ex ia EN 60079-11

EMC Directive

EMI EN 61000-6-4

EMS EN 61000-6-2

RoHS Directive

Safety approval:

FM: Intrinsically safe

Class I, Division 1, Groups A, B, C and D

Class I, Zone 0, AEx ia IIC (US)

Class I, Zone 0, Ex ia IIC (Canada)

T4, T5 and T6

(Class 3610, ANSI/ISA 60079-11,

CAN/CSA-C22.2 No. 157,

CAN/CSA-C22.2 No. 60079-11)

ATEX: Intrinsic safety

 II 1G, Ex ia IIC; T4, T5 and T6 Ga
(EN 60079-0)
(EN 60079-11)

SAFETY PARAMETERS

Operating temperature

For ATEX / FM:

T4: -40 to +80°C

T5: -40 to +60°C

T6: -40 to +45°C

Ex-data:

- Output circuit
 U_i (Vmax): 30 V DC
 I_i (Imax): 96 mA DC
 P_i (Pmax): 720 mW
 C_i : 1 nF
 L_i : 0 mH
- Sensor circuit
 U_o (Voc): 30 V DC
 I_o (Isc): 24 mA DC
 P_o : 180 mW
 C_o (Ca): 50 nF
 L_o (La): 40 mH

INPUT TYPE, RANGE & ACCURACY**■ INPUT TYPE, RANGE & ACCURACY**

Table 1

INPUT TYPE	MIN. SPAN	MAXIMUM RANGE	ACCURACY			
DC mV	4 mV	-10 to +100 mV	±10 μV			
Resistance	25 Ω	0 to 4000 Ω	±0.1 Ω			
THERMOCOUPLE	°C			°F		
	MIN. SPAN	MAXIMUM RANGE	ACCURACY	MIN. SPAN	MAXIMUM RANGE	ACCURACY
K (CA)	50	-180 to +1372	±0.5	90	-292 to +2501	±0.9
E (CRC)	50	-100 to +1000	±0.5	90	-148 to +1832	±0.9
J (IC)	50	-100 to +1200	±0.5	90	-148 to +2192	±0.9
T (CC)	50	-200 to +400	±0.5	90	-328 to +752	±0.9
B (RH)	100	400 to 1820	±1 *1	180	752 to 3308	±1.8 *1
R	100	-50 to +1760	±1 *2	180	-58 to +3200	±1.8 *2
S	100	-50 to +1760	±1 *2	180	-58 to +3200	±1.8 *2
C (WRe 5-26)	100	0 to 2300	±1	180	32 to 4172	±1.8
D (WRe 3-25)	100	0 to 2300	±1	180	32 to 4172	±1.8
N	50	-180 to +1300	±0.5	90	-292 to +2372	±0.9
U	50	-200 to +600	±0.5	90	-328 to +1112	±0.9
L	50	-100 to +900	±0.5	90	-148 to +1652	±0.9
RTD	°C			°F		
	MIN. SPAN	MAXIMUM RANGE	ACCURACY	MIN. SPAN	MAXIMUM RANGE	ACCURACY
Pt 100 (JIS '97, IEC)	10	-200 to +850	±0.15	18	-328 to +1562	±0.27
Pt 500	10	-200 to +850	±0.15	18	-328 to +1562	±0.27
Pt 1000	10	-200 to +850	±0.15	18	-328 to +1562	±0.27
JPt 100 (JIS '89)	10	-200 to +510	±0.15	18	-328 to +950	±0.27

*1. 2°C for 400 to 850°C range, 3.6°F for 752 to 1562°F range.

*2. 2°C for -50 to +100°C range, 3.6°F for -58 to +212°F range.

EXTERNAL DIMENSIONS & TERMINAL ASSIGNMENTS unit: mm [inch]

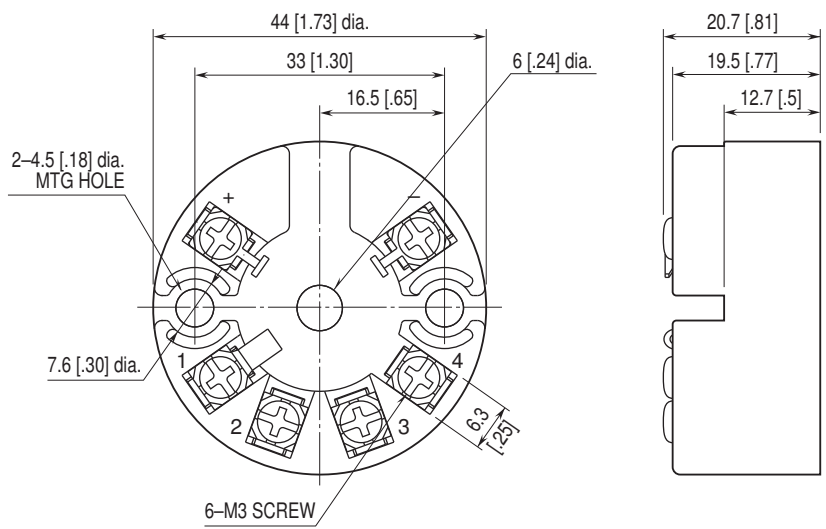

MOUNTING REQUIREMENTS unit: mm [inch]

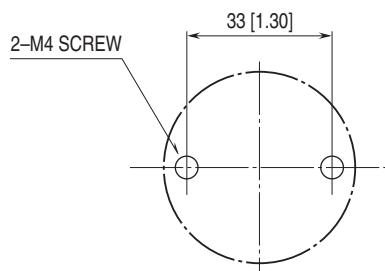

The screws are to be provided by the customer.

SCHEMATIC CIRCUITRY & CONNECTION DIAGRAM

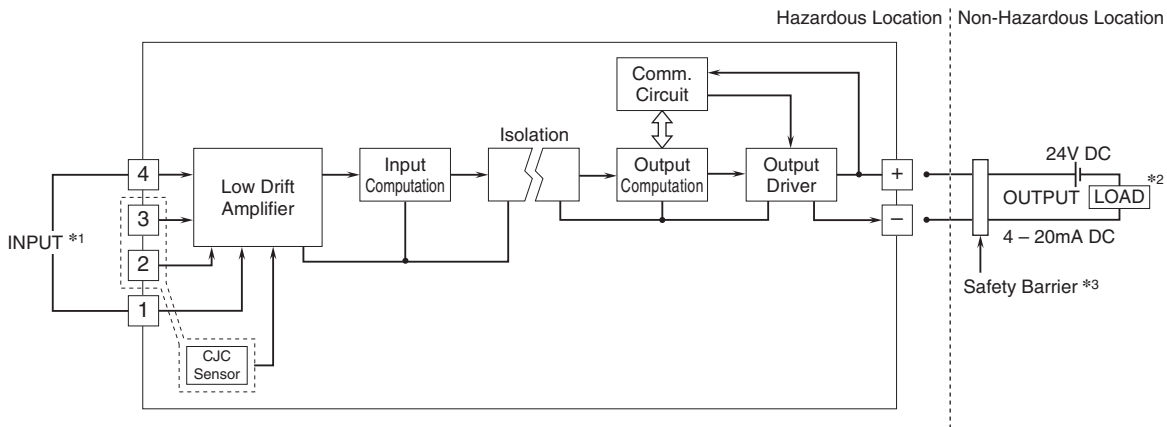

*1. Input Connection Examples

■ DC MILLIVOLT

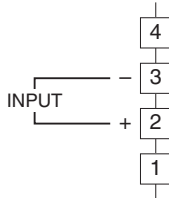

■ THERMOCOUPLE

• Single input

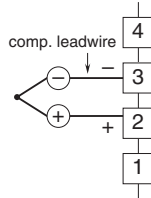

• Dual input

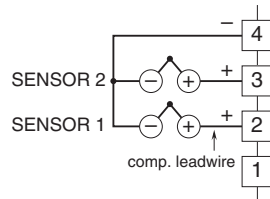

■ RTD & RESISTANCE

• Two-wire

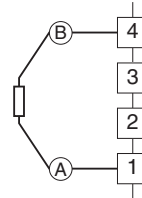

• Three-wire

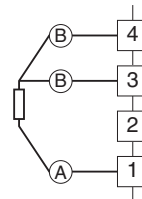

• Four-wire

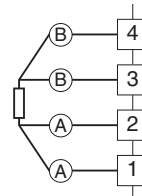

*2. Limited to 250 – 500Ω when using the communication to configure the module.

*3. A safety barrier must be installed for the intrinsic safety. The safety barrier must meet the Ex-data of this unit and must be approved for the hazardous location.



Specifications are subject to change without notice.