

Head-mounted Two-wire Signal Conditioners 27-UNIT

RTD TRANSMITTER

(PC programmable; non-isolated)

Functions & Features

- Accepts direct input from an RTD and provides a standard 4 - 20 mA DC signal
- Suitable for Functional Safety applications up to SIL2
- I/O range programming via PC Configurator
- User's temperature table can be used
- Self diagnostics
- Low temperature drift

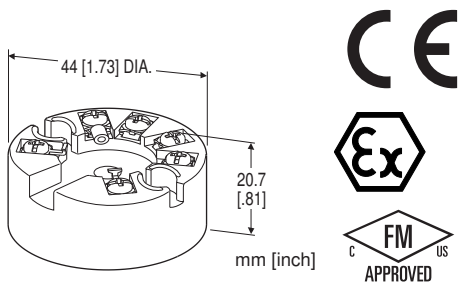

MODEL: 27R-[1][2]

ORDERING INFORMATION

- Code number: 27R-[1][2]
- Specify a code from below for each of [1] and [2]. (e.g. 27R-0/M)
- Use Ordering Information Sheet (No. ESU-7653). Factory standard setting will be used if not otherwise specified.
- Specify the country in which the product is to be used with the Safety Approval code 2.

[1] SAFETY APPROVAL

- 0: None
- 1: FM intrinsically safe (Option code /M is not selectable)
- 2: ATEX intrinsic safety (Option code /M is not selectable)

[2] OPTIONS

Function Monitor LED

- Blank: Without
- /M: With

RELATED PRODUCTS

- USB interface Bell202 modem (model: COP-HU) Usable in 'non-hazardous' area only.
- PC configurator software (model: 27MCFG) Downloadable at M-System's web site.

GENERAL SPECIFICATIONS

- Construction:** Sensor head-mounting
- Connection:** M3 screw terminals (torque 0.5 N·m)
- Screw terminal:** Nickel-plated brass
- Housing material:** Flame-resistant resin (black)
- Function monitor LED:** Input status and error status are displayed by blinking mode.
- User-configurable items:** PC and the transmitter are connected with the COP-HU.
 - Input sensor type
 - Number of wires
 - Input range
 - Burnout
 - Output limits (Upper / Lower)
 - Damping time (factory set to 0)
 - Linearization
 - Output calibration
 - Loop test output

INPUT SPECIFICATIONS

The input is factory set for use with Pt 100 (JIS '97, IEC), 0 to 100°C.

■ RTD (2-wire, 3-wire or 4-wire)

Input resistance: ≥ 1 MΩ

Excitation: 0.2 mA

Allowable leadwire resistance: Max. 10 Ω per wire

Temperature Range

RTD	MIN. SPAN		USABLE RANGE
	°C	°F	
Pt 100 (JIS '97, IEC)	10	18	-200 to +850 -328 to +1562
	18		
Pt 500	10	18	-200 to +850 -328 to +1562
	18		
Pt 1000	10	18	-200 to +850 -328 to +1562
	18		
JPt 100 (JIS '89)	10	18	-200 to +510 -328 to +950
	18		

OUTPUT SPECIFICATIONS

Output range: 4 - 20 mA DC

Operational range: 3.75 - 23 mA

Load resistance vs. supply voltage:

Load Resistance (Ω) = (Supply Voltage (V) - 9 (V)) ÷ 0.023 (A) (including leadwire resistance)

Burnout: 3.75 - 3.8 mA or 21.5 - 23 mA (factory set to 23 mA)

Upper output limit proportional to the input:

20 - 21.5 mA (factory set to 21.5 mA)

Lower output limit proportional to the input:

3.8 - 4 mA (factory set to 3.8 mA)

Update time: 440 msec.

ATEX: Intrinsic safety

⊕ II 1G, Ex ia IIC; T4, T5 and T6 Ga

(EN 60079-0)

(EN 60079-11)

INSTALLATION

Supply voltage

- 9 - 35 V DC (non-approved)
- 9 - 28 V DC (approved)

Operating temperature: -40 to +85°C (-40 to +185°F)

(See Safety Parameters for use in a hazardous location.)

Operating humidity: 0 to 95 %RH (non-condensing)

Mounting: Head-mounting (DIN type B head)

Weight: 50 g (1.76 oz)

PERFORMANCE

Accuracy: $\pm 0.15^\circ\text{C}$ ($\pm 0.27^\circ\text{F}$), $\pm 0.075\%$ of span or

$\pm 0.075\%$ of max. range, whichever is greater

(max. range = 0 % or 100 % value, absolute value of whichever is greater.)

Temp. coefficient: 0.0075 %/°C (0.004 %/°F) of max. range

(max. range = 0 % or 100 % value, absolute value of whichever is greater.)

Response time: ≤ 1 sec. (2- or 3-wire; 0 - 90 %) or

≤ 2 sec. (4-wire; 0 - 90 %) with damping time set to 0

Burnout response time: ≤ 2 sec.

Supply voltage effect: $\pm 0.01\%$ of span/V

Safety integrity level according to IEC 61508: Suitable for use in a safety instrumented system up to SIL2 (together with sensor) if appropriate safety instructions are observed. Consult M-System.

STANDARDS & APPROVALS

EU conformity:

ATEX Directive

Ex ia EN 60079-11

EMC Directive

EMI EN 61000-6-4

EMS EN 61000-6-2

RoHS Directive

Safety approval:

FM: Intrinsically safe

Class I, Division 1, Groups A, B, C and D

Class I, Zone 0, AEx ia IIC (US)

Class I, Zone 0, Ex ia IIC (Canada)

T4, T5 and T6

(Class 3610, ANSI/ISA 60079-11,

CAN/CSA-C22.2 No. 157,

CAN/CSA-C22.2 No. 60079-11)

SAFETY PARAMETERS

Operating temperature

For ATEX / FM:

T4: -40 to +80°C

T5: -40 to +60°C

T6: -40 to +45°C

Ex-data:

- Output circuit

Ui (Vmax): 30 V DC

Ii (Imax): 96 mA DC

Pi (Pmax): 720 mW

Ci: 1 nF

Li: 0 mH

- Sensor circuit

Uo (Voc): 30 V DC

Io (Isc): 24 mA DC

Po: 180 mW

Co (Ca): 50 nF

Lo (La): 40 mH

FUNCTION MONITOR LED (option /M)

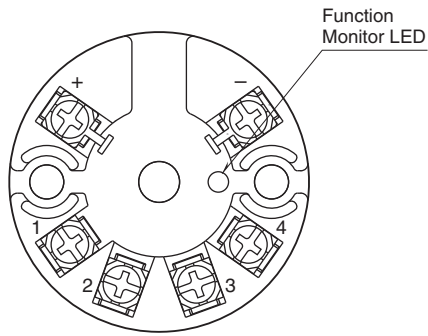

EXTERNAL DIMENSIONS & TERMINAL ASSIGNMENTS unit: mm [inch]

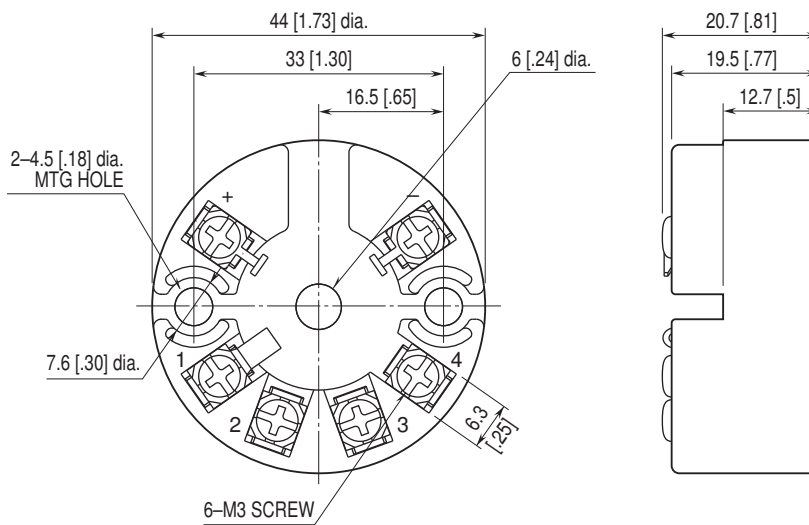

MOUNTING REQUIREMENTS unit: mm [inch]

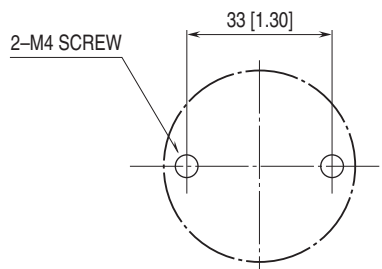

The screws are to be provided by the customer.

SCHEMATIC CIRCUITRY & CONNECTION DIAGRAM

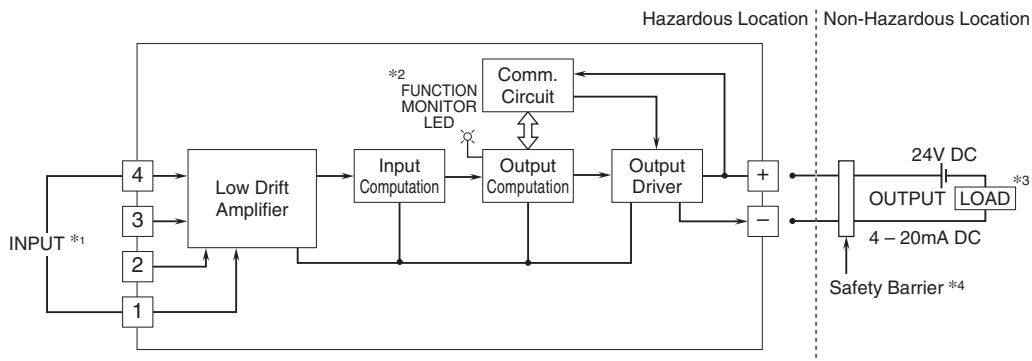

*1. Input Connection Examples

■ RTD & RESISTANCE

• Two-wire

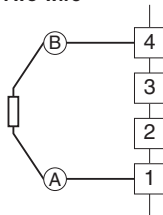

• Three-wire

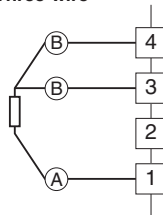

• Four-wire

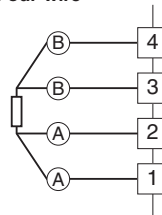

*2. Option /M

*3. Limited to 250 - 500Ω when using the communication to configure the module.

*4. A safety barrier must be installed for the intrinsic safety.

The safety barrier must meet the Ex-data of this unit and must be approved for the hazardous location.



Specifications are subject to change without notice.