

Head-mounted Two-wire Signal Conditioners 27-UNIT

2-WIRE UNIVERSAL TEMPERATURE TRANSMITTER

(HART communication, outdoor enclosure, explosion-proof)

Functions & Features

- Universal input: DC mV, T/C, RTD and resistance
- High accuracy
- HART communication
- Explosion-proof approval
- Suitable for Functional Safety applications up to SIL2
- Programming via hand-held communicator or via PC
- A wide variety of T/C and RTD types
- User's temperature table can be used
- Self diagnostics
- Ultra-low temp. drift option (20 ppm/°C typ.)
- Stainless steel enclosure optional

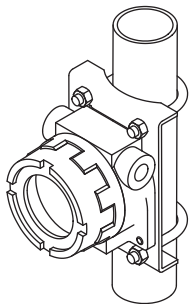

MODEL: 27HU-B-[1][2][3][4][5][6][7]

ORDERING INFORMATION

- Code number: 27HU-B-[1][2][3][4][5][6][7]

Specify a code from below for each of [1] through [7].
(e.g. 27HU-B-0L1T01/S).

Use Ordering Information Sheet (No. ESU-7652). Factory standard setting will be used if not otherwise specified. Specify the country in which the product is to be used with the Safety Approval code 4.

[1] SAFETY APPROVAL

Confirm selectable combinations of approval and wiring conduit types in the table below.

- 0: None
- 3: FM explosion-proof
- 4: ATEX flameproof
- 8: TIIS flameproof (CE not available)

[2] TEMPERATURE DRIFT

- 0: Standard (temp. coefficient 0.015 %/°C)
- L: Ultra-low temperature drift (temp. coefficient 0.002 %/°C typ. 0.005 %/°C max.)

[3] LED INDICATOR

- 0: Without
- 1: With (SIL not available)

[4] TERMINAL BLOCK

- 0: None (Output connection: Terminals on module) (For TIIS, selectable only with 'No indicator' option.)
- T: Incorporated (Selectable only with the LED indicator option)

[5] WIRING CONDUIT

Confirm selectable combinations of approval and wiring conduit types in the table below.

- 0: G 1/2
- 1: 1/2 NPT
- 2: M20 × 1.5
- 3: PG 13.5

[6] MOUNTING BRACKET

- 0: Without
- 1: With

[7] OPTIONS

Enclosure Materials

Blank: Diecast aluminium enclosure

/S: Stainless steel enclosure

(TIIS flameproof approval not selectable)

■ **SELECTABLE WIRING CONDUITS SPECIFIC TO EACH APPROVAL**
'N' marked combinations are not selectable.

WIRING CONDUIT \ APPROVAL	APPROVAL			
	0	3	4	8
0	Y	N	N	Y
1	Y	Y	Y	N
2	Y	N	Y	N
3	Y	N	N	N

RELATED PRODUCTS

- USB interface Bell202 modem (model: COP-HU)
Usable in 'non-hazardous' area only.
- Hand-held communicator
- PC configurator software (model: 27HUCFG)
Downloadable at M-System's web site.
- Cable gland (model: BX-E-SXY)

PACKAGE INCLUDES...

- **Cable gland:** Two provided for TIS flameproof type
Model No.: BX-E-SXY
Cable entries: Elastomeric sealing rings
Wiring conduit size: G 1/2
Material: Chrome-plated brass (entry)
CR (sealing ring)
Applicable wire size: 8 - 12 dia.
- **Mounting screws**
Bolt (M8 x 15): 4 pcs.
Spring washer for M8: 4 pcs.
Material: Stainless steel 304
- **Mounting bracket assembly (option)**
Mounting bracket: 1 pcs.
M10 U-bolt: 2 pcs.
Nut for M10: 4 pcs.
Spring washer for M10: 4 pcs.
Material: Stainless steel 304
Applicable pipe: 1 1/2" min.; 2" max.
- **Engineering unit label (1)**

GENERAL SPECIFICATIONS

Degree of protection: NEMA 4X, IP66/IP67

Wiring conduit: See 'Ordering information.'

Connection:

- **Without terminal block and indicator:** M3 screw terminal in transmitter
(Torque: 0.5 Nm)
- **Without terminal block with indicator:**
Input signal: M3 screw terminal in transmitter
(Torque: 0.5 Nm)
Output signal: Euro terminal
(Applicable wire size: 0.14 to 1.5 mm² (AWG26 to 16),
stripped length: 6 mm)
- **With Terminal block and indicator:**
Input signal: M3 screw terminal in transmitter
(Torque: 0.5 Nm)
Output signal: M3 screws in terminal block
(Torque: 0.5 Nm)

Screw terminal

- Input signal: Nickel-plated brass
- Output signal:
Without terminal block and indicator: Nickel-plated brass
With terminal block and indicator: Nickel-plated steel

Materials

Transmitter Housing: Flame-resistant resin (black)

Indicator Housing: Flame-resistant resin (black)

Enclosure material: Diecast aluminium standard; SCS14 stainless steel casting optional (equivalent to type 316); silver color, epoxy resin coated

Isolation: Input to output to outdoor enclosure

User-configurable items:

- Input sensor type and numbers
- Number of wires (RTD & resistance)
- Input range (inverted range selectable)
- Burnout
- Output limits (Upper / Lower)
- Damping time (factory set to 0)
- Cold junction compensation (T/C; internal or external sensor selectable)
- Linearization
- Sensor calibration
- Output calibration
- HART communication mode

Refer to the HART setup manual or the PC configurator users manual for the detail.

HART COMMUNICATION

Protocol: HART communication protocol

HART address range: 0 - 15 (factory set to 0)

Transmission speed: 1200 bps

Digital current: Approx. 1 mA_{p-p} when communicating

Character format: 1 Start Bit, 8 Data Bits, 1 Odd Parity Bit, 1 Stop Bit

Distance: 1.5 km (0.9 miles)

HART communication mode: Master-Slave Mode and Burst Mode (factory set to Master-Slave)

HART network mode: Point-to-Point Mode and Multi-drop Mode; automatically set to Multi-drop Mode when the address is set to other than 0.

LED INDICATOR (option)

LED: 8 mm (.3") 7-segment, red

Number of display digits: 4

Scaling range: -1999 to 9999

Offset range: -1999 to 9999

Decimal point position: 10⁻¹, 10⁻², 10⁻³, or no decimal point

Polarity sign: Minus (-) sign added automatically according to the computation result

Read rate: 2.5/s

Over-range warning: All segments dark except the top ones that blink with the input exceeding the display/measurable range; or the bottom ones that blink with the input below the range.

Engineering unit display: Unit label included; LED backlight provided

Engineering unit indication: Sticker label attached
DC, AC, W, °C, °F, V, mV, A, mA, %, kW, mW, kV, kA, psi, K, bar, barg, Nℓ/min, kvar, Mvar, var, m, mm, kg, kg/h, kPa, MPa, N·m, Nm³/h, m³/h, m³/sec, m/sec, kgf/cm², ℓ/min, %RH, ℓ, ℓ/h, t/h, rpm, ppm, pH, Pa

INPUT SPECIFICATIONS

The input is factory set for use with K thermocouple, single input, 0 to 100°C, internal CJC sensor.

See Table 1 for the available input type, the minimum span and the maximum range.

■ DC mV (dual input available)

Input resistance: $\geq 1 \text{ M}\Omega$

■ Thermocouple (dual input available)

Input resistance: $\geq 1 \text{ M}\Omega$

Burnout sensing: 33 μA

External CJC sensor type: Pt 100

■ RTD (2-wire, 3-wire or 4-wire)

Input resistance: $\geq 1 \text{ M}\Omega$

Excitation: 0.2 mA

Allowable leadwire resistance: Max. 10 Ω per wire

■ Resistance (2-wire, 3-wire or 4-wire)

Input resistance: $\geq 1 \text{ M}\Omega$

Excitation: 0.2 mA

Allowable leadwire resistance: Max. 10 Ω per wire

OUTPUT SPECIFICATIONS

Output range: 4 - 20 mA DC

Operational range: 3.75 - 23 mA

Load resistance vs. supply voltage:

Load Resistance (Ω) = (Supply Voltage (V) - 8 (V)*) \div 0.023 (A) (including leadwire resistance)

*12 (V) with LED indicator option.

Burnout: 3.75 - 3.8 mA or 21.5 - 23 mA

(factory set to 23 mA)

Upper output limit proportional to the input:

20 - 21.5 mA (factory set to 21.5 mA)

Lower output limit proportional to the input:

3.8 - 4 mA (factory set to 3.8 mA)

Update time: 440 msec. (660 msec. with dual input)

Output characteristics for dual input:

Average or Differential selectable

INSTALLATION

Supply voltage

Non-approved: 8 - 35 V DC (without LED indicator)

12 - 39 V DC (with LED indicator)

ATEX & FM: 8 - 32 V DC (without LED indicator)

12 - 32 V DC (with LED indicator)

TIIS: 8 - 28 V DC (without LED indicator)

12 - 32 V DC (with LED indicator)

Operating temperature

Non-approved: -40 to +85°C (-40 to +185°F)

ATEX & FM: T5, -40 to +80°C (-40 to +176°F)

T6, -40 to +70°C (-40 to +158°F)

TIIS: T6, -20 to +60°C (-4 to +140°F)

Weight:

· Unit

Approx. 1.3 kg (2.9 lb), aluminium

Approx. 4.0 kg (8.8 lb), stainless steel

Approx. 2.0 kg (4.4 lb), TIIS flameproof

· Mounting bracket set (option)

Approx. 0.78 kg (1.72 lb)

PERFORMANCE

Accuracy: See Table 1.

Display accuracy: $\pm 0.01 \text{ mA}$

(Refer to 'how to calculate accuracy against scale'.)

Cold junction compensation accuracy: $\pm 0.5^\circ\text{C}$ ($\pm 0.9^\circ\text{F}$) with internal CJC sensor

LED indicator temp. coefficient: $\pm 0.015 \text{ }^\circ\text{C}$

Response time: $\leq 2 \text{ sec.}$ (0 - 90 %) with damping time set to 0 and when not communicating via HART.

Supply voltage effect: $\pm 0.005 \text{ } \%$ of span/V

Insulation resistance: $\geq 100 \text{ M}\Omega$ with 500 V DC

Dielectric strength: 1500 V AC @1 minute

(input to output to outdoor enclosure)

Safety integrity level according to IEC 61508: Suitable for use in a safety instrumented system up to SIL2 (together with sensor) if appropriate safety instructions are observed. Consult M-System.

HOW TO CALCULATE ACCURACY AGAINST SCALE

Example: 4 - 20 mA input, Scale 0 - 100

Accuracy = $0.01 \text{ mA} \div (20 - 4) \text{ mA} \times 100 = 0.063 \text{ } \%$

Display Error = $(100 - 0) \times 0.063 \text{ } \% = \pm 0.063 \text{ digits}$

STANDARDS & APPROVALS

EU conformity:

ATEX Directive

Ex db EN 60079-1

EMC Directive

EMI EN 61000-6-4

EMS EN 61000-6-2

RoHS Directive

Safety approval:

FM: Explosion-proof and Dust-ignition proof

Class I, Division 1, Groups B, C and D

Class II, Division 1, Groups E, F and G

Class III, Division 1

T5 and T6

(Class 3615)

TIIS: Flameproof

Ex d IIC T6

ATEX: Flameproof

 II 2G, Ex db IIC, T5, T6 Gb

(EN 60079-0)

(EN 60079-1)

INDICATOR TOP VIEW (option)

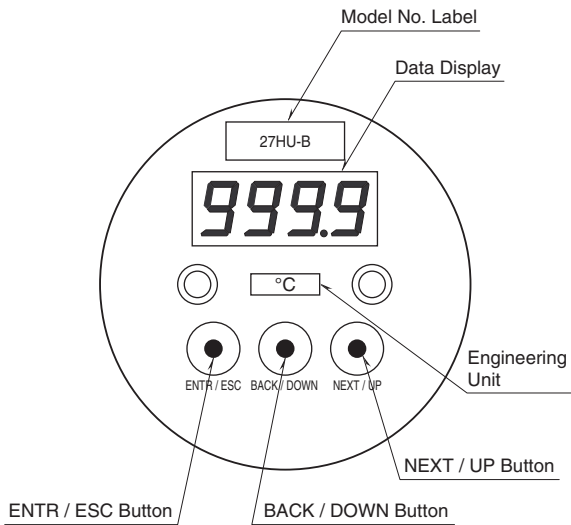

INPUT TYPE, RANGE & ACCURACY

INPUT TYPE			MINIMUM SAPN	MAXIMUM SPAN	ACCURACY *1	TEMPERATURE DRIFT		
						STANDARD DRIFT *2	ULTRA-LOW DRIFT *3	
DC mV			4 mV	-100 to +800 mV	±10 μV	±1.5 μV/°C	±0.5 μV/°C	
Resistance			25 Ω	0 to 4 kΩ	±0.1 Ω	±15 mΩ /°C	±5 mΩ /°C	
Thermocouple	°C			°F			TEMPERATURE DRIFT	
	MINIMUM SAPN	MAXIMUM RENG	ACCURACY *1	MINIMUM SAPN	MAXIMUM RENG	ACCURACY *1	STANDARD DRIFT *2	ULTRA-LOW DRIFT *3
K (CA)	50	-180 to +1372	±0.5	90	-292 to +2501	±0.9	±0.075°C/°C	±0.025°C/°C
E (CRC)	50	-100 to +1000	±0.5	90	-148 to +1832	±0.9	±0.075°C/°C	±0.025°C/°C
J (IC)	50	-100 to +1200	±0.5	90	-148 to +2192	±0.9	±0.075°C/°C	±0.025°C/°C
T (CC)	50	-200 to +400	±0.5	90	-328 to +752	±0.9	±0.075°C/°C	±0.025°C/°C
B (RH)	100	400 to 1820	±1	180	752 to 3308	±1.8	±0.3°C/°C	±0.1°C/°C
R	100	-50 to +1760*4	±1	180	-58 to +3200*4	±1.8	±0.3°C/°C	±0.1°C/°C
S	100	-50 to +1760*4	±1	180	-58 to +3200*4	±1.8	±0.3°C/°C	±0.1°C/°C
C (WRe 5-26)	100	0 to 2300	±1	180	32 to 4172	±1.8	±0.3°C/°C	±0.1°C/°C
D (WRe 3-25)	100	0 to 2300	±1	180	32 to 4172	±1.8	±0.3°C/°C	±0.1°C/°C
N	50	-180 to +1300	±0.5	90	-292 to +2372	±0.9	±0.075°C/°C	±0.025°C/°C
U	50	-200 to +600	±0.5	90	-328 to +1112	±0.9	±0.075°C/°C	±0.025°C/°C
L	50	-100 to +900	±0.5	90	-148 to +1652	±0.9	±0.075°C/°C	±0.025°C/°C
RTD	°C			°F			TEMPERATURE DRIFT	
	MINIMUM SAPN	MAXIMUM RENG	ACCURACY *1	MINIMUM SAPN	MAXIMUM RENG	ACCURACY *1	STANDARD DRIFT *2	ULTRA-LOW DRIFT *3
Pt 100 (JIS '97, IEC)	10	-200 to +850	±0.1	18	-328 to +1562	±0.18	±0.015°C/°C	±0.005°C/°C
Pt 200	10	-200 to +850	±0.1	18	-328 to +1562	±0.18	±0.015°C/°C	±0.005°C/°C
Pt 500	10	-200 to +850	±0.1	18	-328 to +1562	±0.18	±0.015°C/°C	±0.005°C/°C
Pt 1000	10	-200 to +850	±0.1	18	-328 to +1562	±0.18	±0.015°C/°C	±0.005°C/°C
JPt 100 (JIS '89)	10	-200 to +510	±0.1	18	-328 to +950	±0.18	±0.015°C/°C	±0.005°C/°C
Ni 100 (DIN 43760 '87)	10	-60 to +250	±0.2	18	-76 to +482	±0.36	±0.015°C/°C	±0.005°C/°C

- *1. DC mV: Or ±0.05 % of absolute range (greater of 0 % and 100 % range values), whichever is greater.
 Or ±0.2 % of absolute negative range for two inputs including negative ranges, whichever is greater.
 Resistance: Or ±0.05 % of absolute range (greater of 0 % and 100 % range values), whichever is greater.
 Thermocouple: Or ±0.05 % of span, whichever is greater. Add cold junction compensation error.
 RTD: Or ±0.05 % of max. range (greater of 0 % and 100 % range values converted into °C), whichever is greater.
 (For 2- or 3-wire RTD, the value is valid by the sensor calibration after wiring is complete.)

*2. Or ±0.015 % of absolute range/°C (greater of 0 % and 100 % range values), whichever is greater.

*3. Or ±0.005 % of absolute range/°C (greater of 0 % and 100 % range values), whichever is greater.

*4. Conformance range: 50 to 1760°C or 122 to 3200°F

EXTERNAL DIMENSIONS unit: mm [inch]

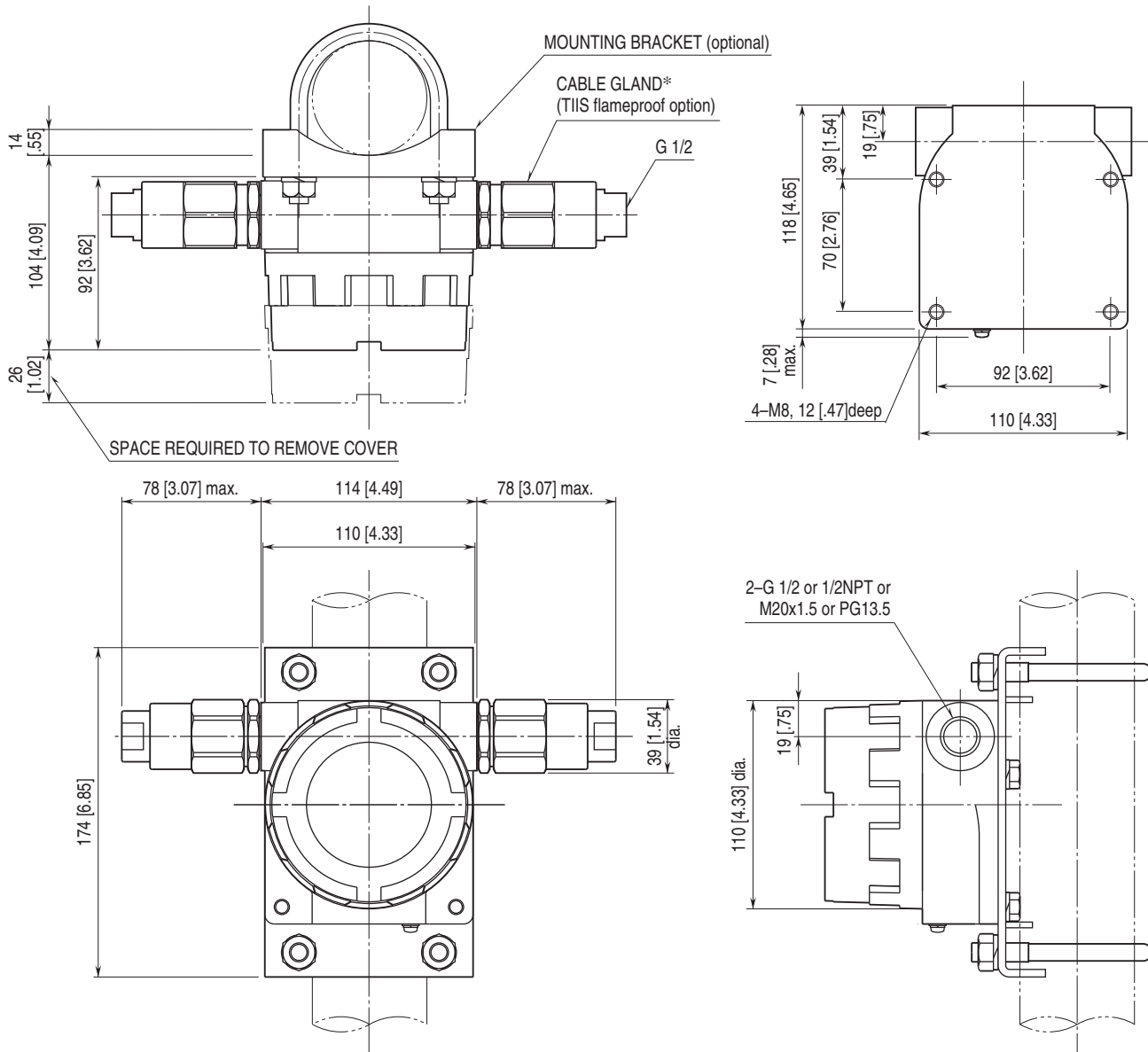

*Two sets of cable gland are attached with TIIS flameproof option.

SCHEMATIC CIRCUITRY & CONNECTION DIAGRAM

- WITHOUT TERMINAL BLOCK (Output connection: Terminals on module)
- Without LED Indicator

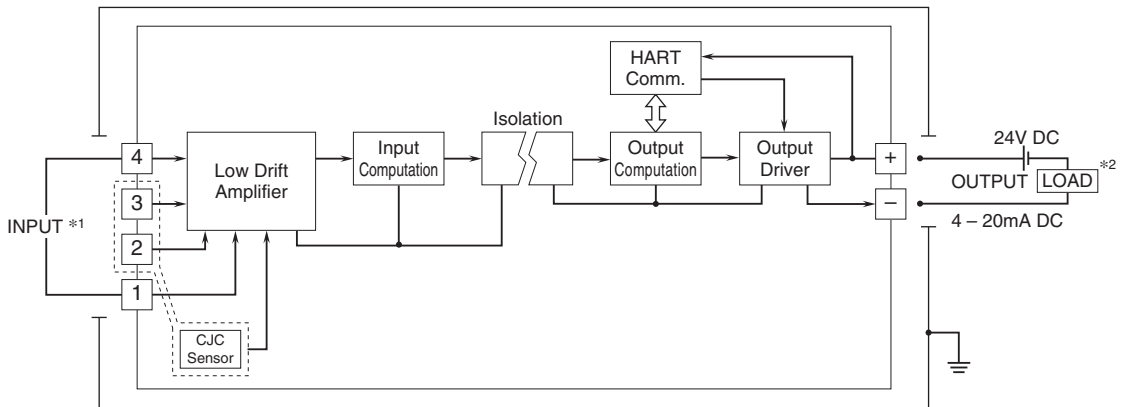

- With LED Indicator

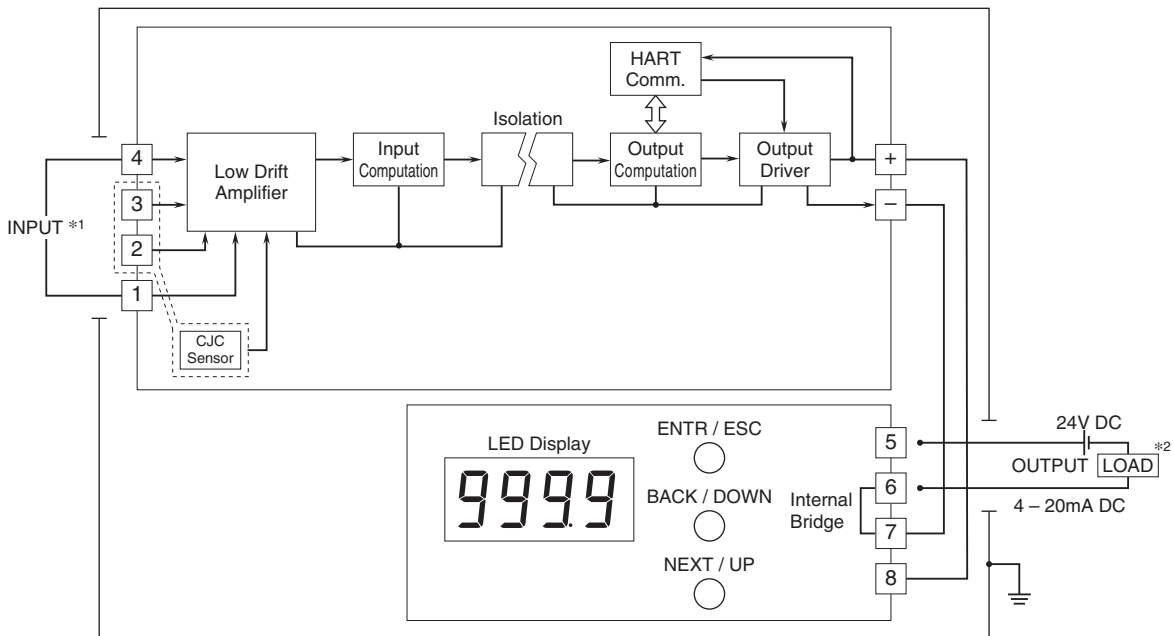

WITH TERMINAL BLOCK

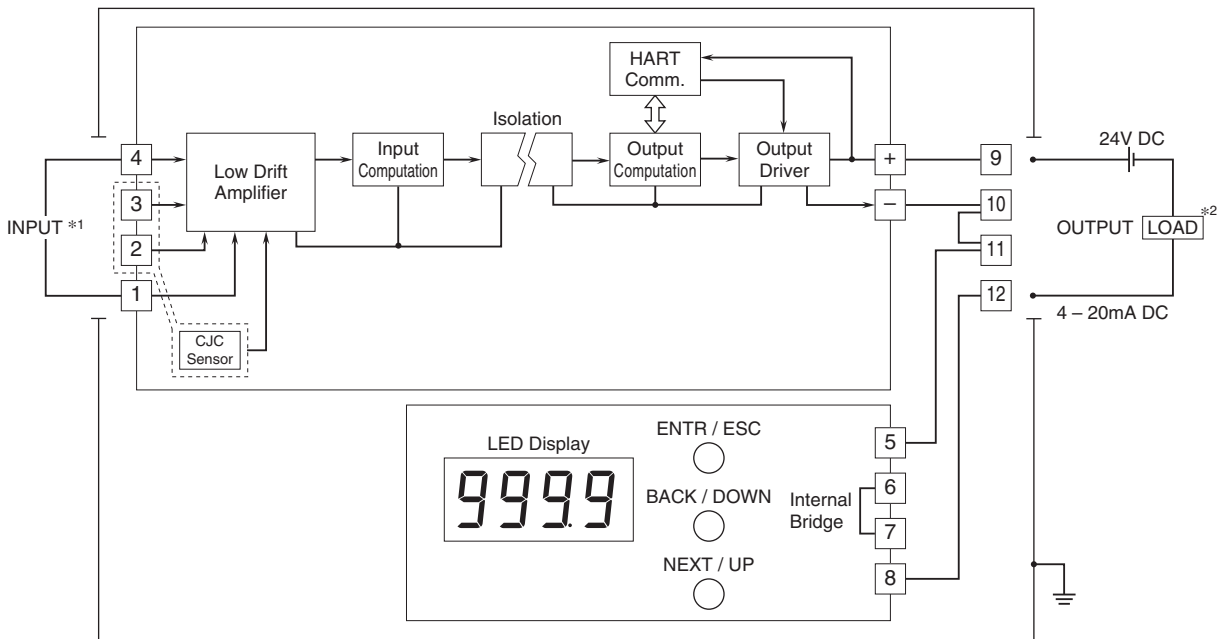

*1. Input Connection Examples

DC MILLIVOLT

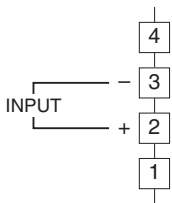

THEMOCOUPLE

Internal CJC

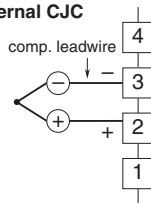

Two Inputs, Internal CJC

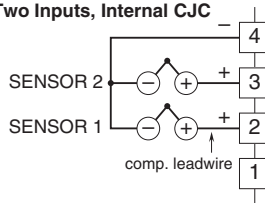

RTD & RESISTANCE

Two-wire

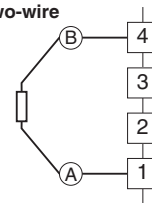

Four-wire

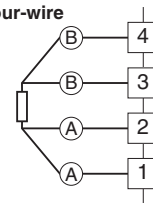

Two Inputs

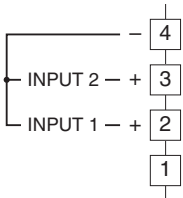

External CJC

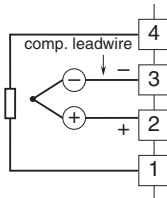

Two Inputs, External CJC

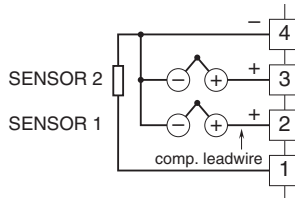

Three-wire

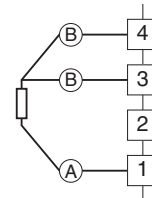

*2. Limited to 250 – 1100 Ω for HART communication



Specifications are subject to change without notice.