

**SERVO-TOP II ELECTRONIC ACTUATOR**  
(linear type; rated thrust 3000N)

MODEL **PSN1G**

**BEFORE USE ....**

Thank you for choosing M-System. Before use, please check contents of the package you received as outlined below. If you have any problems or questions with the product, please contact M-System's Sales Office or representatives.

**■ SAFETY PRECAUTIONS**

Before use, please read all the following precautions carefully to ensure the user's safety. These safety precautions, classified into "WARNING" and "CAUTION" according to the degree of damage that may be caused by improper use of the product, are imperative to prevent an accident. After reading, be sure to keep this manual always in a visible and accessible place for the user.

- △ **WARNING** Suggesting that failure to observe the precautions could result in death or serious personal injury.
- △ **CAUTION** Suggesting that failure to observe the precautions could result in personal injury or damage to the property.

**△ WARNING**

Never fail to attach the transparent protection cover to the power terminal block before turning on the power supply. It could cause electric shock.

Power fuse: A glass tube power fuse (5.2 dia × 20 mm) of the rating as shown below is incorporated for safety. Be sure to remove the power supply before replacing it. Replacing the fuse without turning off the power supply could cause electric shock.  
DC power: Medium time lag, M 6A 125V

Remove the power supply to the actuator before wiring. It could cause electric shock.

Do not disassemble or modify the unit in any way. It could cause electric shock, burn, or injury.

DO NOT step onto the actuator. DO NOT rest a heavy object on or against it. It could cause injury.

When installing the PSN unit outdoor or where it is exposed to rain or water drops, adequate precautions must be taken for preventing water from entering inside through wiring conduits. It could cause electric shock.

DO NOT mount the PSN in such an orientation that the output stem faces upward. It could cause electric shock.

When performing manual operation, be sure that the power supply is removed. A user's hand or arm could be caught, resulting in serious injury.

When the operation is completed, be sure to remove the manual operation handle and cover the stem with a rubber cap. A user's hand or arm could be caught, resulting in serious injury.

**△ CAUTION**

Inside the cover, the stepping motor and the plate at the top may become extremely hot during operation. DO NOT touch with bare hands. It could cause burn injury.

The adjustments which are paint locked are for factory use only and should be changed only by qualified M-System personnel. Otherwise it could cause breakdown. M-System is not liable for any malfunction or inconvenience caused by unauthorized changes made by the user.

**■ PACKAGE INCLUDES:**

SERVO-TOP II body .....(1)

Remark: Yoke and other components necessary to attach the PSN to a valve are to be provided by the customer.

**■ MODEL NO.**

Confirm Model No. marking on the product to be exactly what you ordered.

**■ INSTRUCTION MANUAL**

This manual describes necessary points of caution when you use this product, including installation and connection, hardware setting, and basic maintenance procedures.

When you need to change software settings, please refer to the Operation Manual for Model PU-2x (EM-9255), Section B. This unit is factory adjusted and calibrated according to the Ordering Information included in the product package. If there is no need to change the pre-adjusted setting, skip the sections on PU-2x programming in this manual and the Operation Manual for Model PU-2x.

## POINTS OF CAUTION

### ■ CONFORMITY WITH EU DIRECTIVES

- The actual installation environments such as equipment to be used with, connected devices, and connected wires may affect the protection level of this unit when they are integrated as a system. The user may have to review the CE requirements in regard to the whole system and employ additional protective measures to ensure CE conformity.
- The equipment must be installed such that appropriate clearance is maintained.  
Make sure that wiring (shielded cables, etc.) is performed properly.  
Failure to observe these requirements may invalidate the CE conformance.

### ■ POWER INPUT RATING & OPERATIONAL RANGE

- Locate the power input rating marked on the product and confirm its operational range as indicated below:  
Rating 24V DC: 24V  $\pm$ 10%, approx. 4A

### ■ GENERAL PRECAUTIONS

- DO NOT install signal wires and power supply wires together in one duct because it may cause a malfunction due to inductive noises. Be sure to use shielded cables for the power supply wires.
- If input signals are to be turned on/off with power voltage supplied to the actuator, be sure to specify the output stem operation for when an abnormally low input is detected.

### ■ ENVIRONMENT

- Inside building.  
If outside, keep away from direct sunlight.
- Operating temperature: -25 to +66°C (-13 to +150.8°F)  
When the ambient temperature can be less than 0°C (32°F), keep the power voltage supplied except during installation or maintenance.
- Operating humidity: 30 to 85% RH (non-condensing)
- Vibration: 1G (9.8 m/s<sup>2</sup>) max.
- The actuator must be installed in a place where maintenance and inspection can be conducted. Observe at least 15 cm (5.9 in.) of open space at the top of its cover for maintenance and inspection.
- Keep away from hazardous atmosphere such as explosive or corrosive gases.

### ■ SOUND ACCOMPANYING MOTOR ROTATION

- The stepping motor incorporated in the PSN unit inherently makes a whistling sound during normal operation according to its rotating frequency. DO NOT be alarmed as it is normal.

### ■ PID CONTROL SIGNAL

- Choose PID parameters carefully so that the manipulated variable (MV) remains as stable as possible. Unstable control shortens the life of actuator and valve.

### ■ PACKING

- Be sure that the packing is properly applied when closing the cover after wiring or adjustments.

### ■ SCREW TORQUE

- The torque for tightening screws for the cover is between 2.4 – 3.1 N·m (1.8 – 2.3 ft·lb).

### ■ DESIGNING YOKE

- When a foreign object is caught in the valve, a thrust as great as 3500 N (787 lb) could be generated. Observe enough strength when designing mechanical components such as the yoke and valve stem.
- When the PSN is used in an application such as temperature control of a steam line, the temperature can rise higher than the ambient temperature due to heat conducted or radiated from the piping even when the ambient temperature is within an allowable range. Use a longer yoke for effective heat dissipation and apply insulation material.

### ■ OPERATING CONDITION

- Depending on operating condition, the internal temperature may rise extremely high.
- Operating continuously under such conditions results in short life span or damage of the product and may impair expected performance.
- Operate with an enough margin such as shortening the operational duty time ratio (duty ratio of <50% or less than 13 strokes per minute).

## COMPONENT IDENTIFICATION

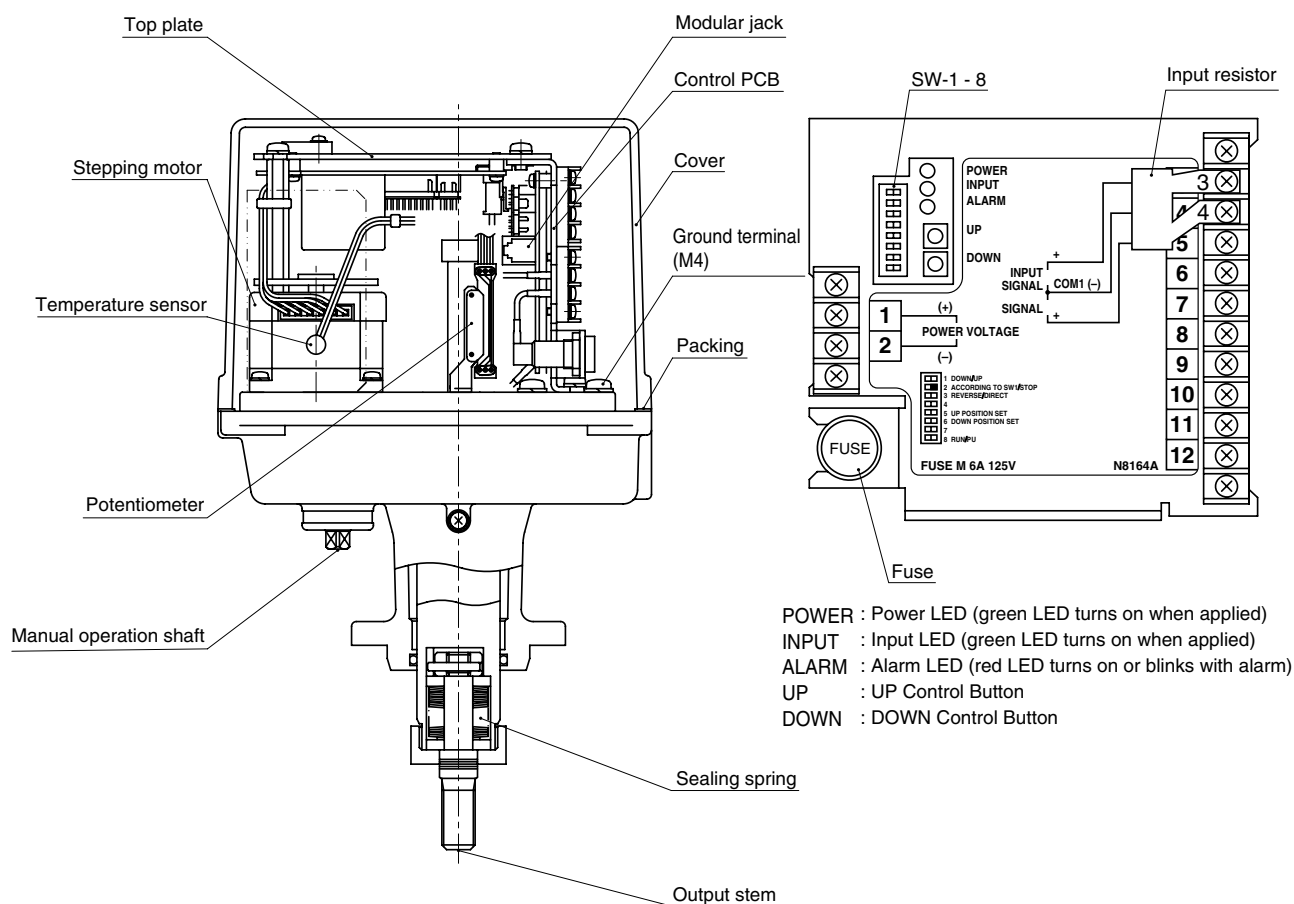

Figure 1. Component Identification

## OUTPUT STEM OPERATION DISTANCE & ADJUSTABLE RANGE

The servo-control PCB compares input signal (position setpoint signal) and actual position signal from the potentiometer, and drives the motor to reduce the deviation.

When a full-close signal is provided, the output stem is pressed onto the sealing spring after the valve is fully closed, until the sealing pressure reaches a preset value.

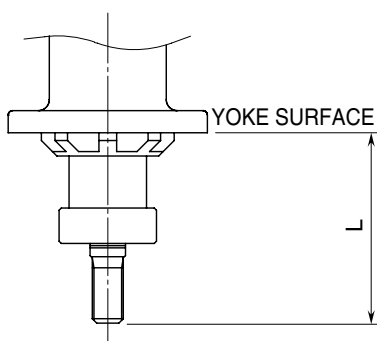

Figure 2. Operational Range of the Output Stem

Model	L (mm)		Operation distance (mm)
	UP	DOWN	
PSN1G-A21-AR	86	106	20

## ELECTRICAL CONNECTIONS

Remove the cover of the PSN unit and wire to the terminal block according to Figure 4.

The PSN starts operating as the power input (1 – 2) and input signal (3 – 4) are applied.

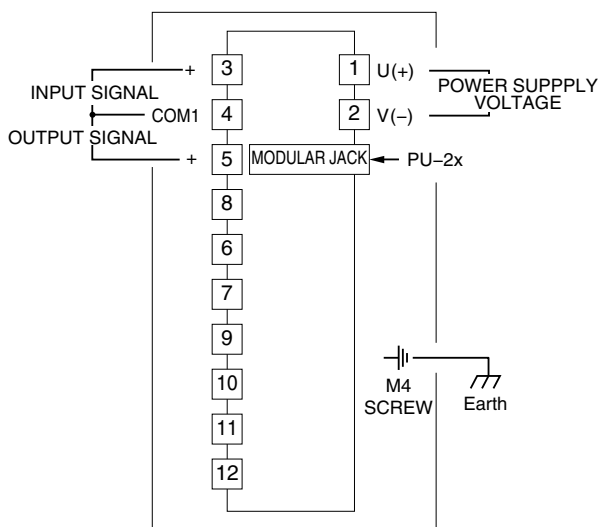
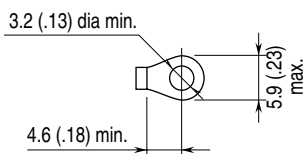

Figure 3 Connection Diagram

### APPLICABLE SOLDERLESS TERMINAL



## ADJUSTMENT PROCEDURE

Remove the PSN unit cover and perform settings and adjustments as appropriate.

### ■ OPERATION AT ABNORMALLY LOW INPUT (SW-1, SW-2)

When the input signal falls to  $1.48 \pm 0.4V$  mA DC or below, the PSN detects an abnormally low input and starts the specified operation.

The operation mode can be changed with the switches as shown in Table 1.

Factory default: Stop

Table 1. Operation at Abnormal low input & SW positions

STEM OPERATION	SW-1	SW-2
Stop	OFF	ON
Extend/move downward	OFF	OFF
Retract/move upward	ON	OFF

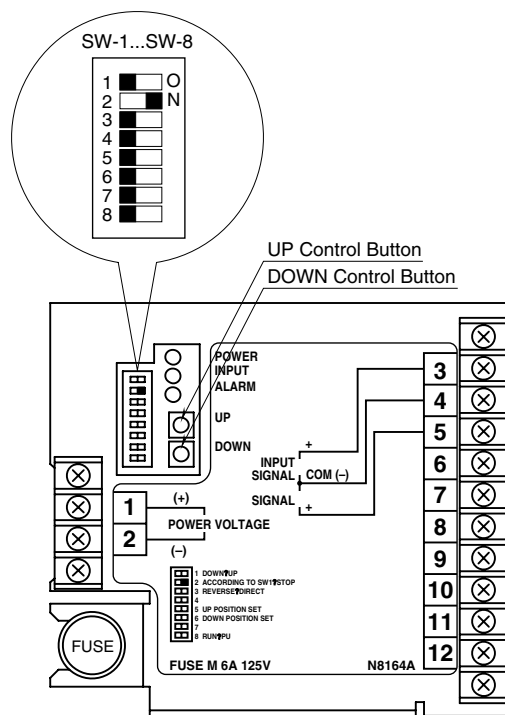

### ■ ACTUATOR ACTION (SW-3)

Turn SW-3 ON or OFF for switching the actuator action with referring to Table 2.

Factory default: Reverse

Table 2. Actuator action

MODE	SW-3	ACTION
Direct	ON	Output stem moves upward as the input decreases. (Valve stem extends.)
Reverse	OFF	Output stem moves downward as the input decreases. (Valve stem retracts.)

Remark: In DIRECT action, the input signal 0 – 100% corresponds to the position output signal 20 – 4mA DC.

## ■ FULL-OPEN(UPPER-END) / FULL-CLOSED(LOWER-END) POSITIONS

- 1) Turn ON SW-8 to switch to the local calibration mode and to disregard the input signal.
- 2) Turn ON SW-5. Adjust the upper-end position pressing UP/DOWN control buttons.
- 3) When the output stem reaches a desired position, turn OFF SW-5. The position is memorized as the upper-end position.
- 4) Turn ON SW-6. Adjust the lower-end position pressing UP/DOWN control buttons.
- 5) When the output stem reaches a desired position, turn OFF SW-6. The position is memorized as the lower-end position.
- 6) Turn OFF SW-8 to switch to the operating mode. Apply input signals and confirm that the output stem reaches the full-open/closed positions accordingly.

## ■ SEALING SPRING

For applying a sealing pressure when the valve is fully closed, adjust flexure of the sealing spring when calibrating the fully opened/closed positions.

For applying a sealing pressure at the both ends, such as the case of a three-way valve, adjust flexure of the sealing spring at the both ends.

Excessive flexure may shorten life of the actuator and spring. Observe the maximum flexure at the maximum pressure.

The output stem is provided with a scale in millimeters.

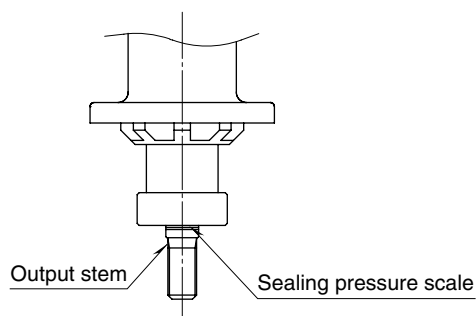

Figure 4. Sealing Spring

Table 3. Sealing Spring

TYPE	MAX. PRESSURE (N)	FLEXTURE AT MAX.PRESS. (mm)	SET PRESS. (IN)	RATED SPRING (N/mm)
3000N	3000	1	2410	590

Remark: The seal spring starts flexing when a pressure exceeding the set pressure is applied.  
Control pressure within 80% of the set pressure except when the valve is fully closed.  
If excessive pressure is applied within the control range, flexure of the spring may jeopardize the linearity.

## PU-2X ADJUSTMENTS

### ■ DISPLAY

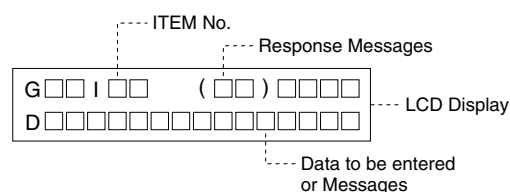

### • Response Messages

- NG: No good  
The PU-2x may not be securely connected.  
Check connection of the modular jack.
- ER: Communication error  
Turn the SW-8 ON.

### • Data Indicator

- OK: OK  
DATA-ERR: Invalid data input  
NON-ITEM: ITEM No. not applicable

## ■ PROGRAMMABLE ITEMS

Table 4 Programmable Items

ITEM No.	ITEM	USABLE RANGE	MINIMUM INCREMENT	DEFAULT
10	Full-open/closed position (upper end)	8 to 100	0.1	95
11	Full-open/closed position (lower end)	0 to 92	0.1	5
12	Upper end limit	75 to 105	0.1	100
13	Lower end limit	-5 to +25	0.1	0
19	Opening/closing speed	-	-	25
20	Deadband	0.1 to 5	0.1	0.1
21	Restart limiting timer	0 to 30	0.1	0.1

## ■ ROM VERSION INDICATION

Press ITEM 99 in the local calibration mode in order to display the ROM version of the PSN.

## ■ HOW TO PROGRAM THE PSN

- 1) Apply power voltage to the PSN.
- 2) Turn ON the SW-8 in order to put the PSN in the local calibration mode, and the input signal is disregarded.
- 3) Connect the modular jack cord of the PU-2x to the PSN.  
ITEM display is blank.
- 4) Indicating Current Setting  
Key in the ITEM No. that you want to check. (N = 0 to 9)  
Press [ITEM] [N] [N].
- 5) Indicating New ITEM No.  
Press [ITEM] [N] [N] or press [UP] or [DOWN].
- 6) Modifying Current Setting  
Display the ITEM No. that you want to change, and press [DATA], new setting, and [ENTER].  
If an irrelevant setting is entered, the PU-2x indicates "DATA-ERR" on its message display. Key in an appropriate setting again.
- 7) Remove the modular jack cord of the PU-2x.
- 8) Turn OFF the SW-8 in order to return the PSN in the operating mode. Apply input signals and confirm every setting.

Remark 1: DO NOT remove power supply voltage to the PSN with the PU-2x connected to it.

Remark 2: Be sure to remove the PU-2x before driving the motor (in the operating mode).

## ■ EXPLANATIONS ABOUT THE PROGRAMMABLE ITEMS

- 1) Full-Open/-Closed Positions (ITEM No.10, 11)  
Key in a percentage value within 0% for the lower end position, and 100% for the upper end position.  
[Lower End] > [Upper End]
- 2) Lower end/Upper end Limits (ITEM No.12, 13)  
The adjustable ranges shown in Table 4 are applicable against the operation distance determined by the full-open/-closed positions as 100%.
- 3) Opening/Closing Speed (ITEM No.19)  
The opening/closing speed is NOT configurable.
- 4) Deadband (ITEM No.20)  
Deadband is adjustable as % of the maximum operation distance within 0.1 to 5%.
- 5) Restart Limiting Timer (ITEM No.21)  
The timer is provided to protect the motor from overheating, preventing it from restarting for a certain interval once the motor has been stopped within deadband.  
When the high temperature protection is activated in a high temperature ambient, adjust the timer to a longer interval.  
Adjustable range is within 0 to 30 sec.

## MANUAL OPERATION

### ■ BY APPLYING POWER VOLTAGE

- 1) Apply power voltage.
- 2) Turn on SW-8 to switch to the local calibration mode.
- 3) Use UP/DOWN control buttons to manually operate the PSN.
- 4) Turn off SW-8 after stopping the power voltage.

### ■ BY USING THE MANUAL OPERATION STEM

Prepare a manual operation handle (model: HPSN) or a tool such as 8-mm ratchet wrench, spanner, etc.

- 1) Be sure that the power voltage is off.
- 2) Turn the manual operation stem clockwise (seen from the operation stem side) to move the output stem upward. Turn the handle with a torque under 1 N·m or 0.74 ft·lb while checking the stem position with the indicator.
- 3) It takes approx. 24 turns to move the output stem by 10 mm.
- 4) When the operation is completed, be sure to remove the handle and cover the stem with a rubber cap.
- 5) Attach the handle only after turning on the power supply.

## PROTECTIVE FUNCTIONS

### ■ ERROR DETECTION

- When the output stem does not operate due to overload or certain malfunction despite there is a deviation between the input signal and the position signal, PSN tries to start the motor by applying a locked rotor torque up to five times. Then, if the stem still does not operate, the unit outputs an alarm signal, turns Alarm LED on, and stops power supply to the motor.
- In order to reset the unit after error detection, apply 0 % and 100 % input signals alternately for several times, or turn off and on the power voltage.
- In case the alarm turns on too often, check for the presence of foreign matter in the valve, inappropriate adjustments, excessive tightening of the valve gland, or other possible causes of the overload.  
Be sure to remove the cause of alarm in order to avoid shortening the life of the product.

### ■ ABNORMAL TEMPERATURE INCREASE PROTECTION

- When the internal temperature sensor detects an abnormal temperature increase in the motor, PSN blinks the alarm LED and stops power supply to the motor until the temperature decreases to an acceptable level.
- Usually, power supply to the motor is automatically resumed in a few minutes, however, it will take longer if the ambient temperature is higher.

### ■ PROTECTIVE FUSE

- A fuse is incorporated for protection against over-current in the control PCB and motor.
- If the power LED does not turn on with the power supplied to the actuator, check the fuse status.
- If a replaced fuse is blown quickly, it is possible that the control PCB and/or motor are damaged. Consult M-System or M-System's representative.

### ■ MOTOR PREHEATING FUNCTION

- When the internal temperature sensor detects a temperature lower than 0°C / 32°F (approximate) on the surface of the motor, the unit supplies current to the motor to warm up the motor to 0°C / 32°F.
- Maintain the power supply on when this unit is used in the ambient temperature below 0°C or 32°F.

## LIGHTNING SURGE PROTECTION

M-System offers a series of lightning surge protectors for protection against induced lightning surges. Please contact M-System to choose appropriate models.

## MAINTENANCE

For effective use and longer life of the PSN, regular checking appropriate for its operating conditions are recommended. Refer to the following table.

ITEM	CHECKING POINT	HOW TO PROCEED
Functioning	Apply input 0%, 50%, 100%, then back to 50%, 0%. Check the actuator operations and positions at each input value.	Repair or calibration If the alarm indicator LED is on, check that the valve operates lightly and smoothly.
Abnormal sound	No abnormal sound is heard during operation.	Repair or calibration
Connector Leadwire	The connector is firmly connected. No breakdown of leadwires. The insulation covers are not torn, not bruised.	Repair or calibration
Inside humidity, rust	No condensation. No rust. If there is water inside, check the packing.	Remove water, dry the case and inside parts. Replace rusted parts. Perform calibration. Replace the packing, if damaged.
Screws	Check that screws and bolts are securely fastened.	Re-tighten them.
Nut	Check that the nut at the valve stem is not loose.	Re-tighten it and calibrate.

For repair or parts replacement, contact M-System or representatives.

### ■ LUBRICATION

There is no need of oiling the PSN in normal operating conditions.

### ■ REGULAR TEST RUNNING

If the valve is not frequently operated, run a test operation regularly (once a week, for example) to check proper functions.

## TROUBLESHOOTING

TROUBLE		POSSIBLE CAUSE	HOW TO PROCEED
Not functioning	Power voltage and/or input indicators OFF	Power voltage and/or input signal is not applied.	Check power voltage and input signals, remove the causes of malfunction and secure the signals.
		Wiring error.	Check the wiring.
		Bad contact.	Check the connector and other connecting sections.
		Fuse melted.	Replace it with a new one.
	Power voltage and input indicators ON	The actuator is in local calibration mode (SW-8 ON).	Turn SW-8 OFF.
		Improper adjustments of full-open/-closed positions.	Adjust the full-open/-closed positions.
		Control PCB damaged.	Repair and calibration.
Unstable functioning	Power voltage is too low or fluctuating.	Motor damaged.	Repair and calibration.
		Abnormality in power voltage or input signal.	Remove the causes of malfunction and secure the power voltage or input signal.
	Input is unstable.	Check the controller and cables. Eliminate noise.	
	Alarm indicator ON	Overload caused by a foreign object caught in the valve.	Remove the causes of overload.
		Actuator mechanism damaged.	Repair.
	Alarm indicator flashing	Motor temperature is abnormally high.	Use the restart limiting timer. Review MV value from the controller.
Wiring of the temperature sensor is broken or the connector is detached.		Check the connector and leadwires.	

For repair or parts replacement, contact M-System or representatives.