

LIGHTNING SURGE PROTECTOR FOR DeviceNet	MODEL	MD-DNM MD-DNS
--	-------	--------------------------

BEFORE USE

Thank you for choosing M-System. Before use, check the package you received as below.

If you have any problems or questions on the product, please contact M-System's Sales Office or representatives.

■ PACKAGE INCLUDES:

Lightning surge protector (1)

■ MODEL NO.

Check that model No. described on specification label is exactly what you ordered.

■ INSTALLATION / INSTRUCTION MANUAL

This manual describes necessary points of caution when you use this product, installation, and basic maintenance procedure.

LIMITATION APPLICABLE TO M-RESTER

The M-Rester will protect electronics equipment from damage caused by lightning by absorbing most of the surge voltages.

However, M-Rester may not be effective against certain extremely high voltages caused by a direct or almost direct hit by lightning.

M-Rester must be installed according to this installation / instruction manual.

GENERAL

■ FUNCTION & FEATURES

- Designed specifically to protect devices connected to DeviceNet from lightning surges

■ SPECIFICATIONS

	Signal Line	Power Line	Drain
Discharge voltage			
Between lines	±5V min.	26V min.	—
Line to ground	±280V min.	±280V min.	±280V min.
Max. surge voltage*			
Between lines	±15V max.	120V max.	—
Line to ground	±800V max.	±650V max.	±800V max.
Response time	≤0.1 μsec.		
Discharge current capacity	1500A		
Max. load current	100mA	8A (MD-DNM) 2A (MD-DNS)	—
Internal series resistance	2Ω x 2	≤0.2Ω	—
Leakage current			
Signal line	≤0.3mA at ±5V DC		
Power line	≤0.3mA at 26V DC		
Line to ground	≤20μA at ±280V DC		
Maximum line voltage	±5V	26V	—
Capacitance			
Signal line	approx. 25 pF @100 kHz		
Line to ground	approx. 25 pF @100 kHz		

*The maximum voltage that could pass through M-RESTER. Protected equipment must be able to withstand this voltage for a very short time period.

POINTS OF CAUTION

■ GENERAL

- Before you remove the unit or mount it, turn off the input signals and power supply to the peripheral devices for safety.

■ ENVIRONMENT

- Indoor use
- When heavy dust or metal particles are present in the atmosphere, install the M-RESTER inside suitably vented housing.
- Do not install the M-RESTER where it is subjected to continuous vibration. Do not apply physical impact to the M-RESTER.
- Environmental temperature must be within -5 to +55°C (23 to 131°F) and relative humidity within 30 to 90% RH in order to ensure adequate life span and operation.
- A small spark may occur when the safety fuse is blown. Be sure that the environment is free from substance that can ignite.

■ WIRING

- Do not connect the communication line across CAN_H and CAN_L. Such a wrong connection may destroy diodes, or result in a network malfunction caused by a power line voltage decrease.

■ DIELECTRIC STRENGTH TEST

- Dielectric strength tests between the DeviceNet wiring and the housing must be conducted at 250V DC or lower voltage. Applying greater voltage will trip the discharge element, and this will cause the test result be 'insulation failure' or 'dielectric breakdown.'

■ AND

- We recommend that you keep spare M-RESTERs so that you can replace them when necessary.

COMPONENT IDENTIFICATION

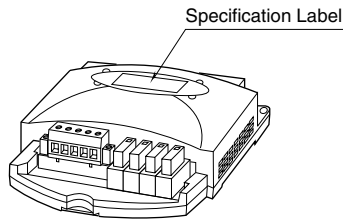

INSTALLATION

■ DIN RAIL MOUNTING

Set the unit so that its mounting adapter is at the bottom. Pull out the adaptor and hung the upper hook at the rear side of unit on the DIN rail. Push in the lower and retract the adaptor, in keeping pressing the unit to the DIN rail.

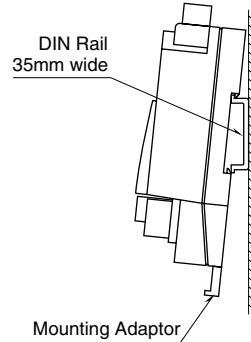

■ WALL MOUNTING

Set the unit so that its mounting adapter is at the bottom. Pull out the adaptor and mount the unit by referring to the External Dimensions in the next page.

TERMINAL CONNECTIONS

Connect the unit as in the diagrams in the next page.

Be sure to cross-wire between the ground terminal (CN4-G) and that of the protected equipment.

When the M-RESTER is connected with a device which has no ground terminal, ground the M-Rester ground terminal only.

■ EXTERNAL DIMENSIONS mm (inch)

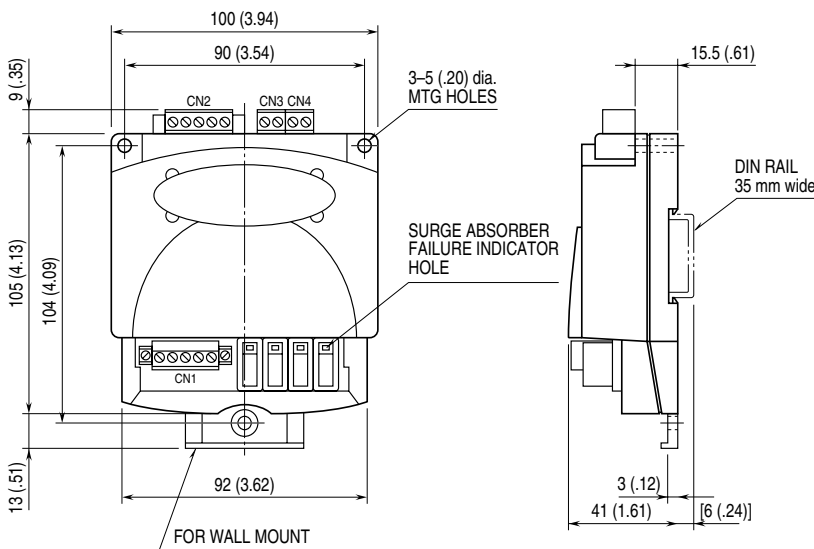

■ TERMINAL WIRING

•CN1

Unit side connector: MSTBV 2,5/5-GF-5,08AU (Phoenix Contact)
Cable side connector: MVSTBR 2,5/5-STF-5,08AUM (Phoenix Contact)

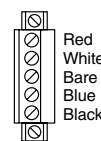

	FUNCTION
Red	V+
White	CAN-H
Bare	DRAIN
Blue	CAN-L
Black	V-

•CN2

Unit side connector: MSTB 2,5/5-GF-5,08AU (Phoenix Contact)
Cable side connector: MSTB 2,5/5-STF-5,08AUM (Phoenix Contact)

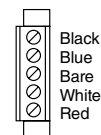

	FUNCTION
Black	V-
Blue	CAN-L
Bare	DRAIN
White	CAN-H
Red	V+

■ SCHEMATIC CIRCUITRY

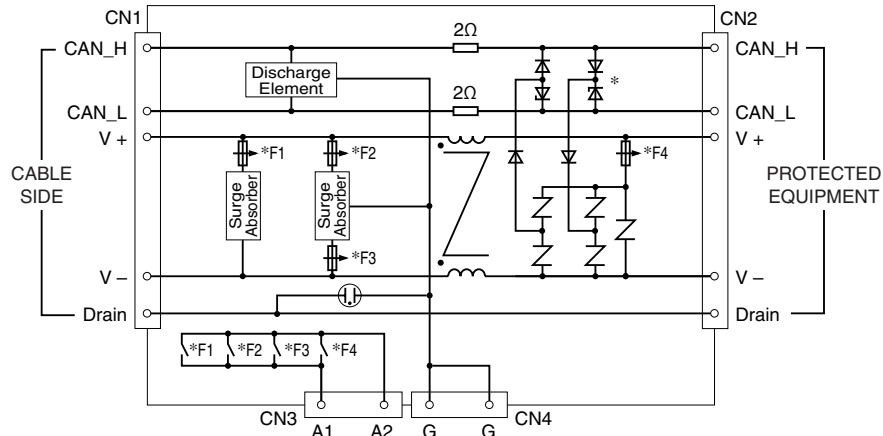

*DO NOT CONNECT the communication line across CAN_H and CAN_L.
Such a wrong connection may destroy diodes, or result in a network malfunction caused by a power line voltage decrease.

■ CONNECTION DIAGRAM

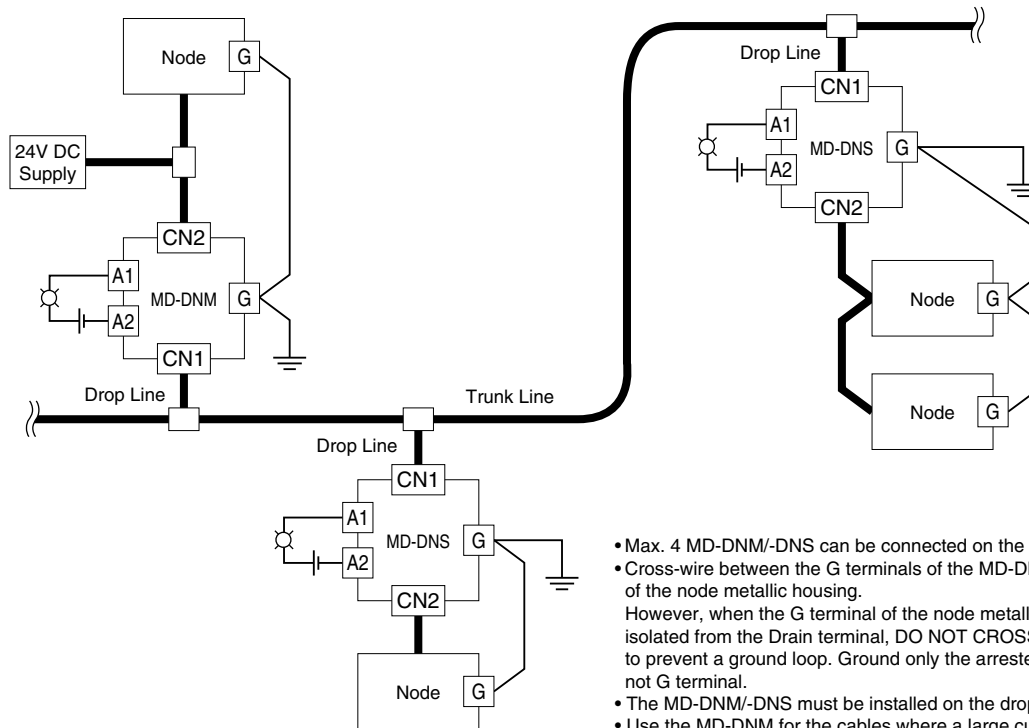

- Max. 4 MD-DNM/-DNS can be connected on the single network.
- Cross-wire between the G terminals of the MD-DNM/-DNS and of the node metallic housing.
However, when the G terminal of the node metallic housing is not isolated from the Drain terminal, DO NOT CROSS-WIRE in order to prevent a ground loop. Ground only the arrester if the node has not G terminal.
- The MD-DNM/-DNS must be installed on the drop lines.
- Use the MD-DNM for the cables where a large current is present.
- The individual and total length of drop lines must be shortened by 1 meter per each MD-DNM/-DNS module.

MAINTENANCE

Check the M-RESTER periodically. Many cases of lightning are ignored, and even lightning at a far distance often causes inductive surges.

We recommend that you check your M-RESTER about twice a year, before and after rainy seasons. Check whenever you experience a strong lightning occurrence.

Checking procedure is explained in the following:

■ CHECKING

WIRING

- Make sure that wiring is done as instructed in the connection diagram.
- Make sure that the ground terminal is connected to the metallic housing of protected equipment.
- Make sure that the ground terminal is grounded to earth.

ALARM CONTACT & ALARM INDICATOR

- With alarm relay contact (CN3), check the alarm status.
- Without alarm relay contact, check the alarm indicator. If the indicator is white, replace the M-RESTER immediately.

DISCHARGE ELEMENTS

Remove all wiring connected to the M-RESTER when you test the discharge elements.

- Check resistance across the following terminals on the high resistance range of a multimeter (3V max.) and confirm no conduction. (The meter will indicate the same value as it will show when these terminals are open except: CN1 (CAN_H) – CN1 (CAN_L) will show 100kΩ minimum, CN1 (V +) – CN1 (V –) will show 10MΩ minimum.)

CN1 (CAN_H) – CN1 (CAN_L)

CN1 (V +) – CN1 (V –)

CN1 (CAN_H) – CN4 (G)

CN1 (CAN_L) – CN4 (G)

CN1 (V +) – CN4 (G)

CN1 (V –) – CN4 (G)

Drain – CN4 (G)

- Check that discharging occurs across the same terminals with a 500V DC/1000MΩ megger. (Indicator of the megger will show less than 20MΩ.)
- If any of the above tests shows negative, replace the M-RESTER.