

FREQUENCY TRANSMITTER
(field-selectable freq. range)

MODEL

6PA

BEFORE USE

Thank you for choosing M-System. Before use, please check contents of the package you received as outlined below. If you have any problems or questions with the product, please contact M-System's Sales Office or representatives.

■ PACKAGE INCLUDES:

- Signal conditioner(1)
- (Option) DIN rail mounting plate (model: A-31)(1 set)
- (Option) Spring clip (model: A-02).....(1 set)

■ MODEL NO.

Confirm Model No. marking on the product to be exactly what you ordered.

■ INSTRUCTION MANUAL

This manual describes necessary points of caution when you use this product, including installation, connection and basic maintenance procedures.

POINTS OF CAUTION

■ GENERAL PRECAUTIONS

- Before you remove the unit or mount it, turn off the power supply and input signal for safety.

■ ENVIRONMENT

- Indoor use.
- When heavy dust or metal particles are present in the air, install the unit inside proper housing with sufficient ventilation.
- Do not install the unit where it is subjected to continuous vibration. Do not subject the unit to physical impact.
- Environmental temperature must be within -5 to +70°C (23 to 158°F) with relative humidity within 30 to 90% RH in order to ensure adequate life span and operation.

■ WIRING

- Do not install cables close to noise sources (relay drive cable, high frequency line, etc.).
- Do not bind these cables together with those in which noises are present. Do not install them in the same duct.

■ AND

- The unit is designed to function as soon as power is supplied, however, a warm up for 10 minutes is required for satisfying complete performance described in the data sheet.

COMPONENT IDENTIFICATION

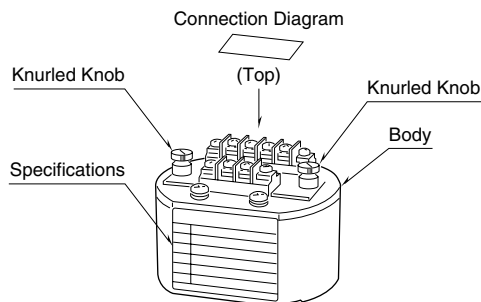

INSTALLATION

■ 35-mm DIN RAIL MOUNTING PLATE A-31 (optional) unit: mm (inch)

- 1) Attach the unit to the DIN rail mounting plate with screws included in the package.
- 2) Set the plate so that its DIN rail adapter is at the bottom. Hang the upper hook at the rear side on the DIN rail and push in the lower. When removing the plate, push down the DIN rail adapter utilizing minus screwdriver and pull.

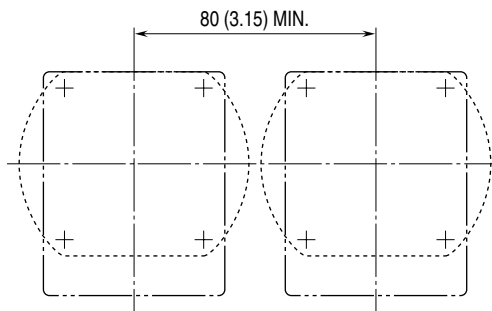

■ SPRING CLIP A-02 (optional)

- 1) Remove the two flat-head screws **A** located at the bottom as shown to the right.
- 2) Set Spring Clip **B** on the mounting hole **B** and tighten it as shown to the right with a binding screw **C** included in the package.
- 3) Check that the clips contract and release smoothly.

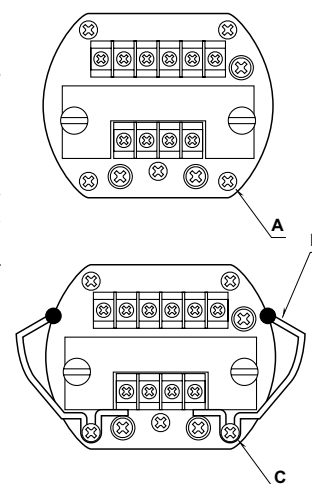

TERMINAL CONNECTIONS

Connect the unit as in the diagram below or refer to the connection diagram on the top of the unit.

EXTERNAL DIMENSIONS unit: mm (inch)

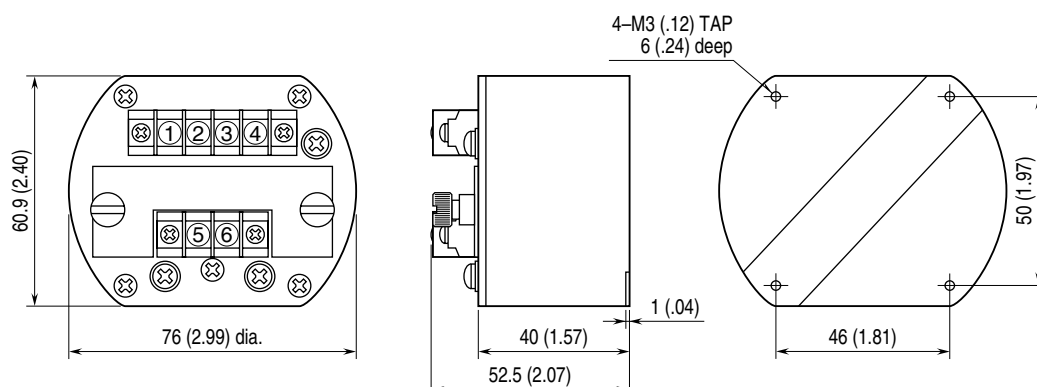

CONNECTION DIAGRAM

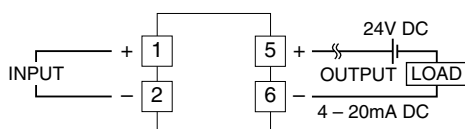

WIRING INSTRUCTIONS

SCREW TERMINAL

Torque: 0.6 N·m

CHECKING

- 1) Terminal wiring: Check that all cables are correctly connected according to the connection diagram.
- 2) Input: Check that the input signal is within 0 – 100% of the full-scale.
- 3) Output: Check that the load is within the permissible limit including wiring resistance.

$$\text{Load Resistance } (\Omega) = \frac{\text{Supply Voltage (V)} - 13 \text{ (V)}}{0.02 \text{ (A)}}$$

(including leadwire resistance)

ADJUSTMENT PROCEDURE

This unit is calibrated at the factory to meet the ordered specifications, therefore you usually do not need any calibration.

For matching the signal to a receiving instrument or in case of regular calibration, adjust the output as explained in the following. Zero and Span adjustments are located behind the top cover. Release the knurled knobs and open the cover.

PREPARATION

- 1) Loosen Screw (A) on top and open the covering.

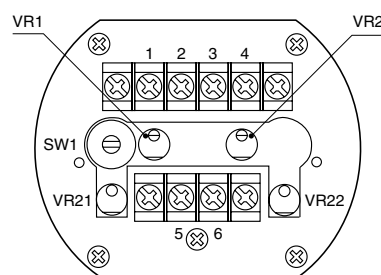
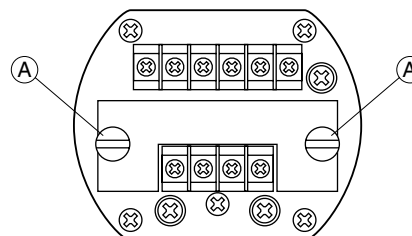

- SW1 : Frequency Selector
- VR1 : Zero Adjustment
- VR2 : Span Adjustment (fine)
- VR21 : Bias Adjustment
- VR22 : Span Adjustment (coarse)

- 2) Make wiring as shown below. Turn power supply on, and warm up for about 10 minutes.

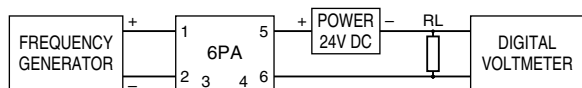

RL: STANDARD LOAD (250Ω ±0.1%)
DIGITAL VOLTMETER: 4 DIGITS

• Requirements for Calibration Equipment

Frequency Generator: Accuracy ±0.04% or better required.

Digital Voltmeter: 4-digit meter.

Accuracy ±0.01% or better required.

All calibration instruments must meet or exceed the above mentioned specifications. M-System does not guarantee this product's stated accuracies and specifications if these calibration requirements are not met.

■ INPUT FREQUENCY RANGE SETTING

Use SW1 for the frequency range setting.

SW1	FREQUENCY RANGE (Hz)*			
	36 ≤ < 100	100 ≤ < 240	240 ≤ < 480	480 ≤ < 1000
1	34 – 38	85 – 95	170 – 190	340 – 380
2	38 – 43	95 – 105	190 – 220	380 – 430
3	43 – 48	105 – 120	220 – 240	430 – 480
4	48 – 54	120 – 135	240 – 270	480 – 540
5	54 – 60	135 – 150	270 – 300	540 – 600
6	60 – 66	150 – 165	300 – 330	600 – 660
7	66 – 74	165 – 185	330 – 370	660 – 740
8	74 – 82	185 – 205	370 – 410	740 – 820
9	82 – 92	205 – 230	410 – 460	820 – 920
10	92 – 102	230 – 255	460 – 510	920 – 1020
11	102 – 114	255 – 285	510 – 570	1020 – 1140
12	114 – 130	285 – 325	570 – 650	1140 – 1300

SW1	FREQUENCY RANGE (kHz)*		
	1 ≤ < 2.4	2.4 ≤ < 4.8	4.8 ≤ < 12
1	0.85 – 0.95	1.7 – 1.9	3.4 – 3.8
2	0.95 – 1.05	1.9 – 2.2	3.8 – 4.4
3	1.05 – 1.20	2.2 – 2.4	4.4 – 4.8
4	1.20 – 1.35	2.4 – 2.7	4.8 – 5.4
5	1.35 – 1.50	2.7 – 3.0	5.4 – 6.0
6	1.50 – 1.65	3.0 – 3.3	6.0 – 6.6
7	1.65 – 1.85	3.3 – 3.7	6.6 – 7.4
8	1.85 – 2.05	3.7 – 4.1	7.4 – 8.2
9	2.05 – 2.30	4.1 – 4.6	8.2 – 9.2
10	2.30 – 2.55	4.6 – 5.1	9.2 – 10.2
11	2.55 – 2.85	5.1 – 5.7	10.2 – 11.4
12	2.85 – 3.25	5.7 – 6.5	11.4 – 13.0

* The frequency range can only be changed within the adjustment range of the frequency variable range covering the input range that you specified.

Example: If you specified the input range of 0 – 150 Hz

The range can be changed within 85 – 325 Hz.

■ OUTPUT ZERO & SPAN ADJUSTMENT

- 1) Turn the bias adjustment (VR21) fully counterclockwise.
- 2) ZERO: With 0% input frequency, adjust output to 0 ±0.05% with VR1.
- 3) SPAN: With 100% input frequency, adjust output to 100 ±0.05% with VR22 after turning VR2 fully counterclockwise and then 1.5 turns clockwise.
- 4) Check ZERO adjustment again with 0% input frequency.
- 5) When ZERO value is changed, repeat the above procedure 2) – 4).

MAINTENANCE

Regular calibration procedure is explained below:

■ CALIBRATION

Warm up the unit for at least 10 minutes. Apply 0%, 25%, 50%, 75% and 100% input signal. Check that the output signal for the respective input signal remains within accuracy described in the data sheet. When the output is out of tolerance, recalibrate the unit according to the "ADJUSTMENT PROCEDURE" explained earlier.

LIGHTNING SURGE PROTECTION

M-System offers a series of lightning surge protector for protection against induced lightning surges. Please contact M-System to choose appropriate models.