

Space-saving Dual Output Signal Conditioners Mini-MW Series

AC TRANSMITTER

Functions & Features

- Converts an alternating current/voltage input into a standard process signal
- True RMS sensing
- Two independent output ranges
- CE marking
- UL approval

Typical Applications

- Converting high AC current in combination with a shunt resistor, or narrow span AC voltage

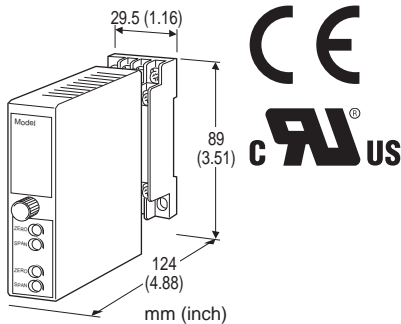

MODEL: W2AC-[1][2][3]-[4][5]

ORDERING INFORMATION

- Code number: W2AC-[1][2][3]-[4][5]
Specify a code from below for each [1] through [5].
(e.g. W2AC-A1AA-M2/CE)
- Special output ranges (For codes AZ, A8, Z & 0)
If one of the outputs should be a current range, specify it for the Output 1 to allow a greater load.

[1] INPUT

Current

- AA:** 0 - 10 mA AC (Input resistance 100 Ω)
- AB:** 0 - 50 mA AC (Input resistance 20 Ω)
- AC:** 0 - 100 mA AC (Input resistance 10 Ω)
- AD:** 0 - 500 mA AC (Input resistance 1 Ω)
- AZ:** Specify current (See INPUT SPECIFICATIONS)
(0 % input must be 0 mA.)

Voltage

- A1:** 0 - 100 mV AC (Input resistance Approx. 100 kΩ min.)
- A2:** 0 - 500 mV AC (Input resistance Approx. 100 kΩ min.)
- A3:** 0 - 1 V AC (Input resistance Approx. 100 kΩ min.)
- A4:** 0 - 5 V AC (Input resistance Approx. 100 kΩ min.)

- A5:** 0 - 10 V AC (Input resistance Approx. 100 kΩ min.)
- A6:** 0 - 120 V AC (Input resistance Approx. 100 kΩ min.)
- A7:** 0 - 150 V AC (Input resistance Approx. 100 kΩ min.)
- A8:** Specify voltage (Input resistance Approx. 100 kΩ min.)
(0 % input must be 0 V.)

[2] OUTPUT 1

Current

- A:** 4 - 20 mA DC (Load resistance 750 Ω max.)
- B:** 2 - 10 mA DC (Load resistance 1500 Ω max.)
- C:** 1 - 5 mA DC (Load resistance 3000 Ω max.)
- D:** 0 - 20 mA DC (Load resistance 750 Ω max.)
- E:** 0 - 16 mA DC (Load resistance 900 Ω max.)
- F:** 0 - 10 mA DC (Load resistance 1500 Ω max.)
- G:** 0 - 1 mA DC (Load resistance 15 kΩ max.)
- Z:** Specify current (See OUTPUT SPECIFICATIONS)

Voltage

- 1:** 0 - 10 mV DC (Load resistance 10 kΩ min.)
- 2:** 0 - 100 mV DC (Load resistance 100 kΩ min.)
- 3:** 0 - 1 V DC (Load resistance 1000 Ω min.)
- 4:** 0 - 10 V DC (Load resistance 10 kΩ min.)
- 5:** 0 - 5 V DC (Load resistance 5000 Ω min.)
- 6:** 1 - 5 V DC (Load resistance 5000 Ω min.)
- 4W:** -10 - +10 V DC (Load resistance 10 kΩ min.)
- 5W:** -5 - +5 V DC (Load resistance 5000 Ω min.)
- 0:** Specify voltage (See OUTPUT SPECIFICATIONS)

[3] OUTPUT 2

Y: None

Current

- A:** 4 - 20 mA DC (Load resistance 350 Ω max.)
- B:** 2 - 10 mA DC (Load resistance 700 Ω max.)
- C:** 1 - 5 mA DC (Load resistance 1400 Ω max.)
- D:** 0 - 20 mA DC (Load resistance 350 Ω max.)
- E:** 0 - 16 mA DC (Load resistance 430 Ω max.)
- F:** 0 - 10 mA DC (Load resistance 700 Ω max.)
- G:** 0 - 1 mA DC (Load resistance 7000 Ω max.)
- Z:** Specify current (See OUTPUT SPECIFICATIONS)

Voltage

Same range availability as Output 1

[4] POWER INPUT

AC Power

- M2:** 100 - 240 V AC (Operational voltage range 85 - 264 V, 47 - 66 Hz)
(90 - 264 V for UL)

DC Power

- R:** 24 V DC
(Operational voltage range 24 V ±10 %, ripple 10 %p-p max.)
- R2:** 11 - 27 V DC
(Operational voltage range 11 - 27 V, ripple 10 %p-p max.)

(Select 'N' for 'Standards & Approvals' code.)

P: 110 V DC

(Operational voltage range 85 - 150 V, ripple 10 %p-p max.)

(110 V \pm 10 % for UL)

[5] OPTIONS

STANDARDS & APPROVALS (must be specified)

/N: Without CE or UL

/CE: CE marking

/UL: UL approval (CE marking)

GENERAL SPECIFICATIONS

Construction: Plug-in

Connection: M3 screw terminals (torque 0.8 N·m)

Housing material: Flame-resistant resin (black)

Isolation: Input to output 1 to output 2 to power

Input waveform

RMS sensing: Up to 15 % of 3rd harmonic content

Overrange output: 0 to 120 % at 1 - 5 V

Zero adjustment: -5 to +5 % (front)

Span adjustment: 95 to 105 % (front)

INPUT SPECIFICATIONS

Frequency: 40 Hz min., 1 kHz max. with 100% input

• **AC Current:** 0 - 1 A AC; input resistor incorporated

Minimum span: 1 mA

Input resistance

Range 1 mA: 1 k Ω

Range \leq 2 mA: 500 Ω

Range \leq 5 mA: 200 Ω

Range \leq 10 mA: 100 Ω

Range \leq 20 mA: 50 Ω

Range \leq 50 mA: 20 Ω

Range \leq 100 mA: 10 Ω

Range \leq 500 mA: 1 Ω

Range \leq 1 A: 0.5 Ω

• **AC Voltage:** 0 - 250 V AC

Minimum span: 50 mV

Input resistance: Approx. 100 k Ω min.

OUTPUT SPECIFICATIONS

• **DC Current:** 0 - 20 mA DC

Minimum span: 1 mA

Offset: Max. 1.5 times span

Load resistance: Output drive 15 V max. for Output 1;

7 V max. for Output 2

• **DC Voltage:** -10 - +12 V DC (up to 10 V for Output 2)

Minimum span: 5 mV

Offset: Max. 1.5 times span

Load resistance: Output drive 1 mA max.; at \geq 0.5 V

INSTALLATION

Power Consumption

• **AC Power input:**

Approx. 4 VA at 100 V

Approx. 5 VA at 200 V

Approx. 6 VA at 240 V

• **DC Power input:** Approx. 3 W

Operating temperature: -5 to +55°C (23 to 131°F)

Operating humidity: 30 to 90 %RH (non-condensing)

Mounting: Surface or DIN rail

Weight: Approx. 200 g (0.44 lbs)

PERFORMANCE in percentage of span

Accuracy: \pm 0.4 %

Temp. coefficient: \pm 0.05 %/°C (\pm 0.03 %/°F)

Response time: \leq 0.7 sec. (0 - 90 %)

Ripple: 0.5 %p-p max. (50/60 Hz)

Line voltage effect: \pm 0.1 % over voltage range

Insulation resistance: \geq 100 M Ω with 500 V DC

Dielectric strength: 2000 V AC @1 minute (input to output 1 to output 2 to power to ground)

STANDARDS & APPROVALS

CE conformity:

EMC Directive (2004/108/EC)

EN 61000-6-4 (EMI)

EN 61000-6-2 (EMS)

Low Voltage Directive (2006/95/EC)

EN 61010-1

Installation Category II

Pollution Degree 2

Max. operating voltage 300 V

Input or output 1 or output 2 to power: Reinforced insulation

Input to output 1 to output 2: Basic insulation

Approval:

UL/C-UL nonincendive Class I, Division 2,

Groups A, B, C, and D hazardous locations

(UL 1604, CAN/CSA-C22.2 No.213)

UL/C-UL general safety requirements

(UL 61010B-1, CAN/CSA-C22.2 No.1010-1)

DIMENSIONS unit: mm (inch)

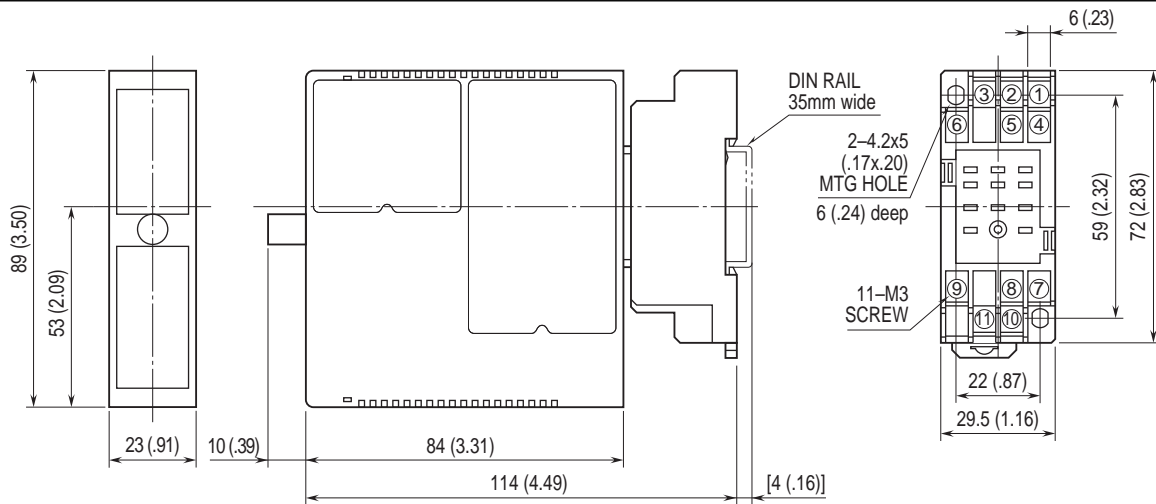

• When mounting, no extra space is needed between units.

SCHEMATIC CIRCUITRY & CONNECTION DIAGRAM

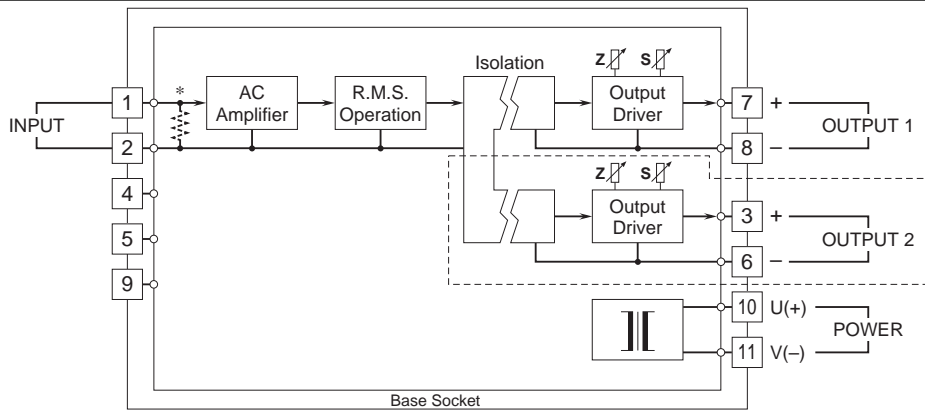

*Input shunt resistor incorporated for current input.

Remark: The section enclosed by broken line is only with 2nd output option.



Specifications are subject to change without notice.