

## Remote I/O R7F4D Series

### HIGH-SPEED LINK SYSTEM I/O MODULE

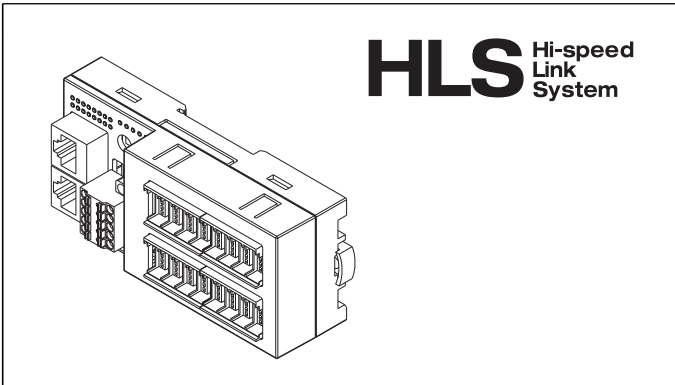

### MODEL: R7F4DH-[1]-[2]-R[3]

#### ORDERING INFORMATION

- Code number: R7F4DH-[1]-[2]-R[3]
- Specify a code from below for each [1] through [3]  
(e.g. R7F4DH-1-DA16A-R/H)

#### [1] TERMINAL BLOCK

- 1: Tension clamp terminal block for power supply  
RJ-45 Modular jack for communication  
e-CON connector for I/O
- 2: Tension clamp terminal block for power supply  
RJ-45 Modular jack for communication  
MIL connector 1 for I/O
- 3: Tension clamp terminal block for power supply  
RJ-45 Modular jack for communication  
MIL connector 2 for I/O
- 4: Tension clamp terminal block for power supply  
RJ-45 Modular jack for communication  
Tension clamp terminal block for I/O

#### [2] I/O TYPE

- DA16A:** NPN discrete input, 16 points  
**DA16B:** PNP discrete input, 16 points  
**DC16A:** NPN transistor output, 16 points  
**DC16B:** PNP transistor output, 16 points  
**DAC16A:** PNP discrete input &  
 NPN transistor output, 8 points each  
**DAC16B:** NPN discrete input &  
 PNP transistor output, 8 points each  
**DAC16C:** NPN discrete input &  
 NPN transistor output, 8 points each  
**DAC16D:** PNP discrete input &  
 PNP transistor output, 8 points each

#### POWER INPUT

**DC Power**  
 R: 24 V DC

#### [3] OPTIONS

**Communication Mode**  
 blank: Full-duplex  
 /H: Half-duplex

#### FUNCTIONS & FEATURES

The R7F4DH interfaces discrete I/O signals with a PLC via HLS.  
 (HLS is the abbreviation for "High-speed Link System" of Step Technica Co., Ltd.)

#### GENERAL SPECIFICATIONS

- **Common Specifications**
- Power input:** 24 V DC  $\pm 10\%$ ; ripple 10 %p-p max.  
**Sensor excitation:** 24 V DC  $\pm 10\%$ ; ripple 5 %p-p max.,  $\leq 2$  A (including discrete I/O load charge)  
**Insulation resistance:**  $\geq 100$  M $\Omega$  with 500 V DC  
**Dielectric strength:** 1500 V AC @1 minute (between isolated circuits)  
**Operating temperature:** -10 to +55°C (14 to 131°F)  
**Operating humidity:** 30 to 90 %RH (non-condensing)  
**Atmosphere:** No corrosive gas or heavy dust  
**Mounting:** DIN rail or wall  
**Communication mode:** Full-duplex or half-duplex
- Network cable**
- Full-duplex communication:  
 ZHY262PS and ZHT262PS (Shinko Seisen Industry Co., Ltd.)  
 Half-duplex communication:  
 ZHY221PS (Shinko Seisen Industry Co., Ltd.)
- Transmission distance:**  
 12 Mbps: 100 meters (328 ft)  
 6 Mbps: 200 meters (656 ft)  
 3 Mbps: 300 meters (984 ft)  
 (Baud rate configurable with DIP SW; factory setting: 12 Mbps)
- Terminating resistor:** Built-in (Selected with the DIP SW; factory setting: disabled)  
**Power indicator:** PWR LED on with power supplied  
**Status indicator:** RUN LED on in normal communication  
**Discrete I/O status indicator:** Red LED on in contact.  
**Station address:** 01H - 3FH (Set with rotary switch)  
**Communication Failure Detection:** At communication error, the output status until normal data is received (Hold or OFF) can be set with the DIP SW. (only for output devices; factory setting: Hold)
- **Current Consumption & Weight**
- R7F4DH-x-DA16A: Approx. 25 mA/100 g (0.22 lbs)

R7F4DH-x-DA16B: Approx. 25 mA/100 g (0.22 lbs)  
R7F4DH-x-DC16A: Approx. 50 mA/100 g (0.22 lbs)  
R7F4DH-x-DC16B: Approx. 50 mA/100 g (0.22 lbs)  
R7F4DH-x-DAC16A: Approx. 35 mA/100 g (0.22 lbs)  
R7F4DH-x-DAC16B: Approx. 35 mA/100 g (0.22 lbs)  
R7F4DH-x-DAC16C: Approx. 35 mA/100 g (0.22 lbs)  
R7F4DH-x-DAC16D: Approx. 35 mA/100 g (0.22 lbs)  
(Discrete I/O load charge is not included in the above-mentioned current consumption.)

**EXTERNAL VIEW**

■ **TERMINAL CODE 1 (e-CON)**

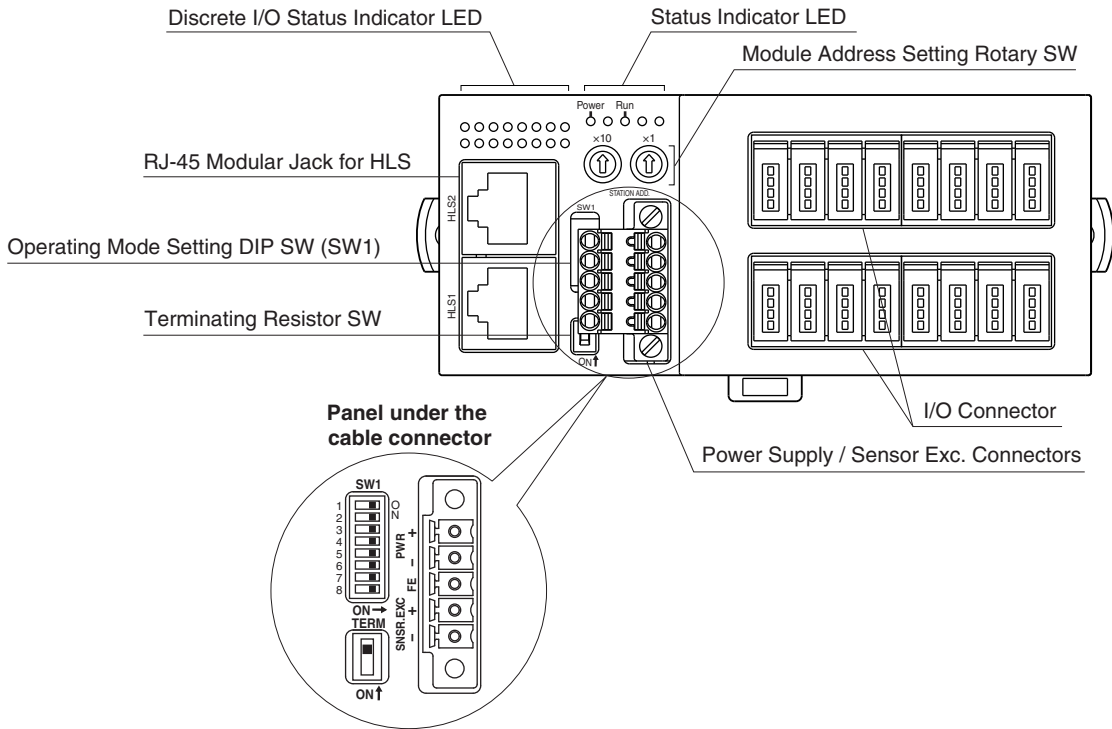



## CONNECTION DIAGRAMS

### ■ I/O connection (Refer to each model terminal assignment)

#### • e-CON connector

**Recommended cable connector:** 37104-( )-000FL (3M Company)

(The cable connector is not included in the package.)

Specify wire size instead of ( ); refer to the specifications of the product.)

#### • MIL connector

**Recommended cable connector:** XG4M-2030 (Omron)

(The cable connector is not included in the package.)

#### • Tension clamp terminal block

**Cable connector:** FMC1,5/16-ST-3,5 (Phoenix Contact)

(The cable connector is included in the package.)

**Applicable wire size:** 0.2 – 1.5 mm<sup>2</sup>; stripped length 10 mm

#### Recommended solderless terminal

- AI0,25–12BU 0.25 mm<sup>2</sup> (Phoenix Contact)
- AI0,34–12TQ 0.34 mm<sup>2</sup> (Phoenix Contact)
- AI0,5–10WH 0.5 mm<sup>2</sup> (Phoenix Contact)
- AI0,75–10GY 0.75 mm<sup>2</sup> (Phoenix Contact)
- A1–10 1.0 mm<sup>2</sup> (Phoenix Contact)
- A1,5–10 1.5 mm<sup>2</sup> (Phoenix Contact)

### ■ POWER SUPPLY

**Cable connector:** TFMC1,5 / 5–STF–3,5

(Phoenix Contact) (included in the package)

**Applicable wire size:** 0.2 – 1.5 mm<sup>2</sup>; stripped length 10 mm

#### Recommended solderless terminal

- AI0,25–12BU 0.25 mm<sup>2</sup> (Phoenix Contact)
- AI0,34–12TQ 0.34 mm<sup>2</sup> (Phoenix Contact)
- AI0,5–10WH 0.5 mm<sup>2</sup> (Phoenix Contact)
- AI0,75–10GY 0.75 mm<sup>2</sup> (Phoenix Contact)
- A1–10 1.0 mm<sup>2</sup> (Phoenix Contact)
- A1,5–10 1.5 mm<sup>2</sup> (Phoenix Contact)

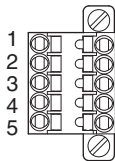

- |              |                   |
|--------------|-------------------|
| 1. PWR+      | Power Supply      |
| 2. PWR–      | Power Supply      |
| 3. FE        | Functional earth  |
| 4. SNSR.EXC+ | Sensor excitation |
| 5. SNSR.EXC– | Sensor excitation |

**■ NETWORK**

**Recommended cable connector:** TM21P-88P (Hirose Electric)  
(not included in the package)

**• Full-duplex communication**

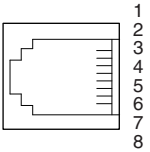

- 1. NC Unused
- 2. NC Unused
- 3. TXD+ Network (slave, transmission +)
- 4. TXD- Network (slave, transmission -)
- 5. RXD+ Network (master, transmission +)
- 6. RXD- Network (master, transmission -)
- 7. NC Unused
- 8. SLD Shield

**• Half-duplex communication**

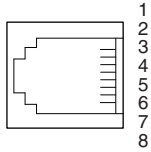

- 1. NC Unused
- 2. NC Unused
- 3. TR+ Network (+)
- 4. TR- Network (-)
- 5. NC Unused
- 6. NC Unused
- 7. NC Unused
- 8. SLD Shield

**■ MASTER CONNECTION**

**• Full-duplex communication**

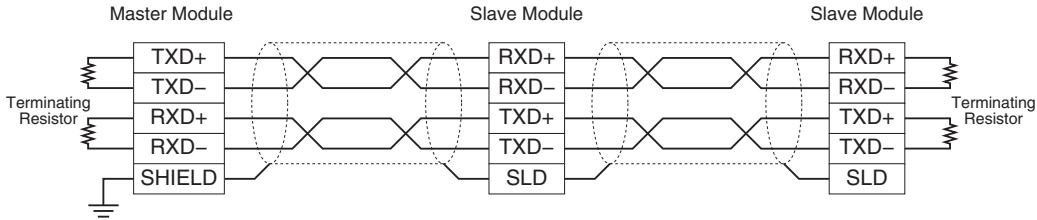

**• Half-duplex communication**

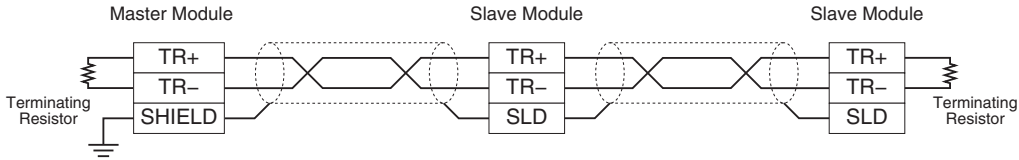

Note: Be sure to turn ON the switch of the terminating resistor located at both ends of the modules.

**I/O DATA DESCRIPTIONS**

■ DISCRETE INPUT

• Di

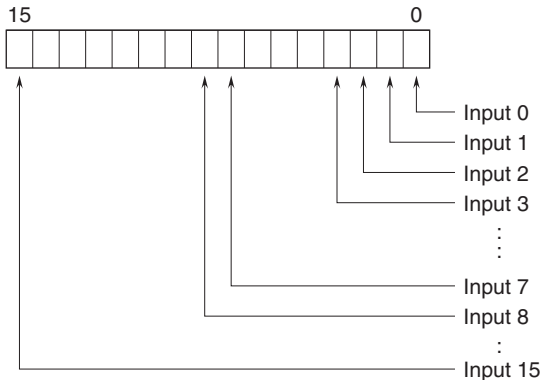

0: OFF  
1: ON

• Do

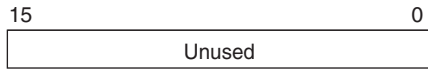

■ DISCRETE OUTPUT

• Di

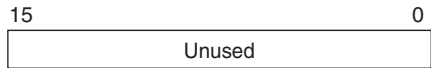

• Do

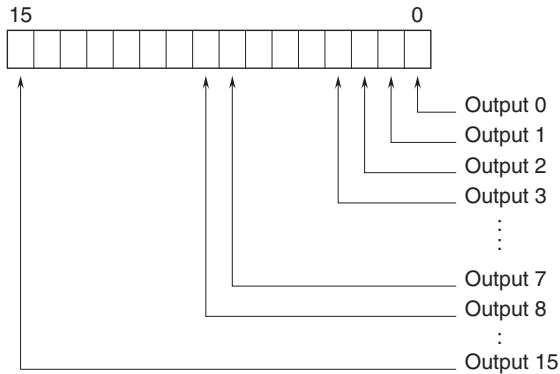

■ DISCRETE I/O

• Di

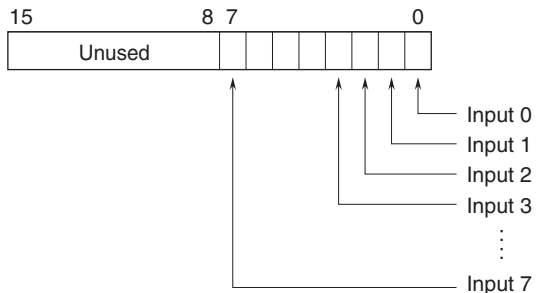

• Do

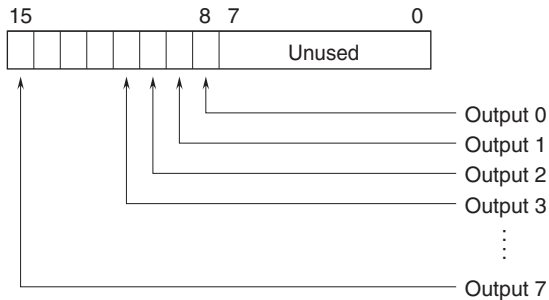

**DIMENSIONS unit: mm (inch)**

■ **TERMINAL CODE 1 (e-CON)**

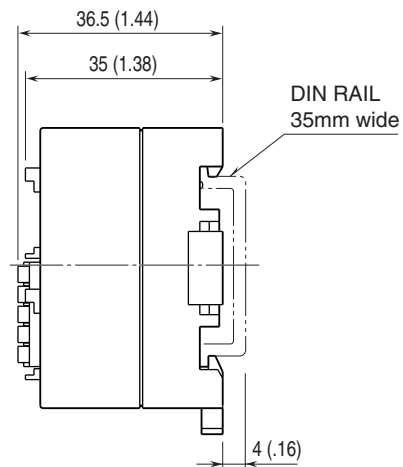
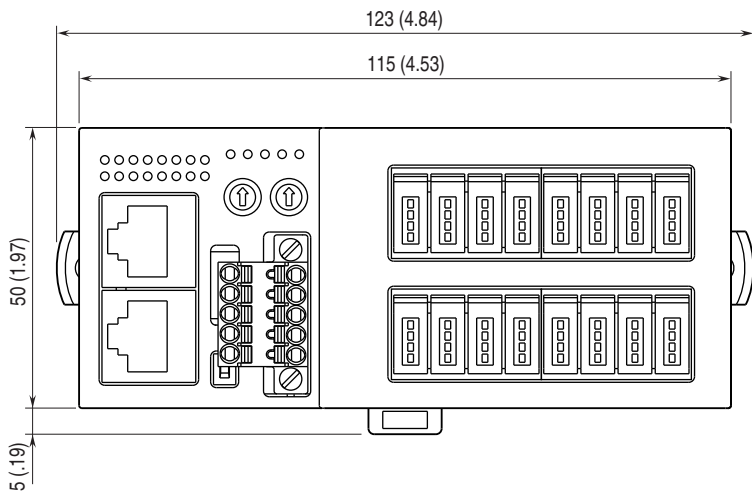

■ **TERMINAL CODE 2, 3 (MIL)**

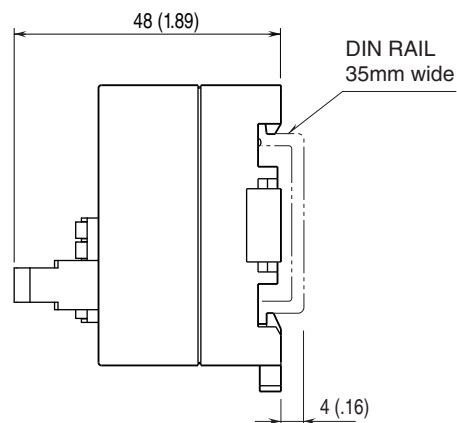
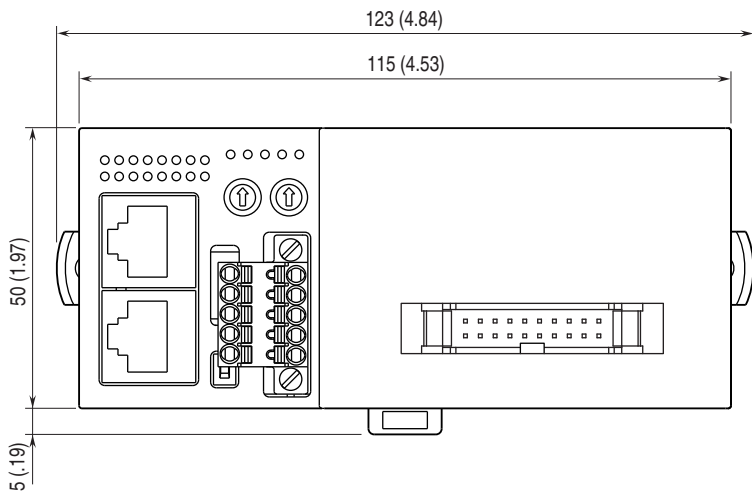

■ **TERMINAL CODE 4 (Tension Clamp)**

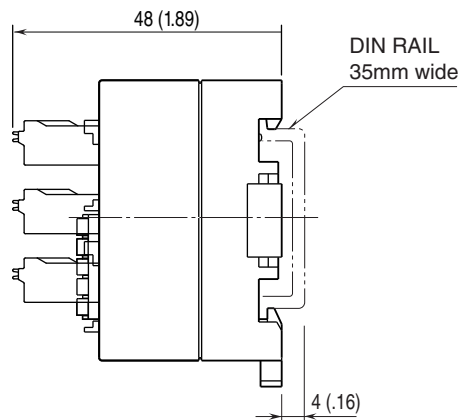
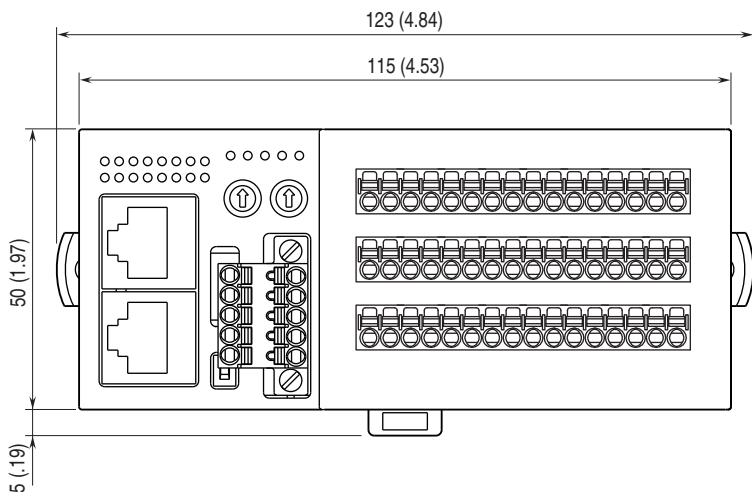

**MOUNTING REQUIREMENTS unit: mm (inch)**

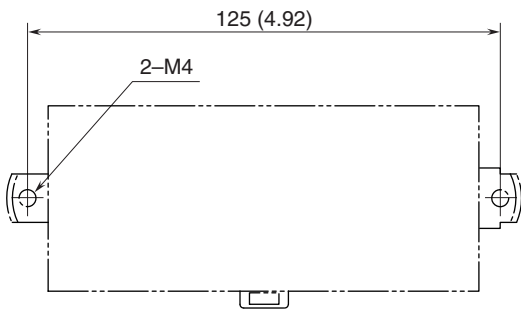

## NPN DISCRETE INPUT MODULE, 16 points

(e-CON connector)

### MODEL: R7F4DH-1-DA16A

#### SPECIFICATIONS

**Common:** Positive common (NPN) per 16 points

**Number of I/O:** Input, 16 points

**Maximum inputs applicable at once:** No limit (at 24 V DC)

**I/O status indicator:** LED turns on with closed contact.

**Isolation:** Input or sensor excitation to HLS to power input to FE

**Data allocation:** 1

**Rated input voltage:** 24 V DC  $\pm 10\%$ ; ripple 5 %p-p max.

**ON voltage / current:**  $\geq 15$  V DC (input - +24V) /  $\geq 3.5$  mA

**OFF voltage / current:**  $\leq 5$  V DC (input - +24V) /  $\leq 1$  mA

**Input current:**  $\leq 5.5$  mA per point at 24 V DC

**Input resistance:** Approx. 4.4 k $\Omega$

**ON delay:**  $\leq 0.5$  msec.

**OFF delay:**  $\leq 0.5$  msec.

#### TERMINAL ASSIGNMENTS

##### Input Connection

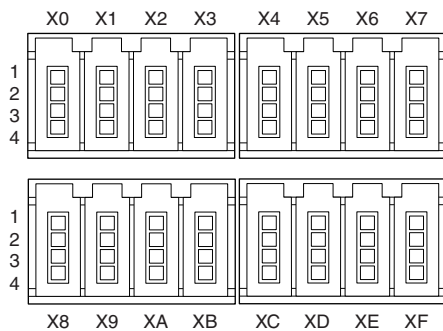

No.	ID	FUNCTION	No.	ID	FUNCTION
X0	1	+24V	X8	1	+24V
	2	NC		2	NC
	3	GND		3	GND
	4	X0		4	X8
X1	1	+24V	X9	1	+24V
	2	NC		2	NC
	3	GND		3	GND
	4	X1		4	X9
X2	1	+24V	XA	1	+24V
	2	NC		2	NC
	3	GND		3	GND
	4	X2		4	XA
X3	1	+24V	XB	1	+24V
	2	NC		2	NC
	3	GND		3	GND
	4	X3		4	XB
X4	1	+24V	XC	1	+24V
	2	NC		2	NC
	3	GND		3	GND
	4	X4		4	XC
X5	1	+24V	XD	1	+24V
	2	NC		2	NC
	3	GND		3	GND
	4	X5		4	XD
X6	1	+24V	XE	1	+24V
	2	NC		2	NC
	3	GND		3	GND
	4	X6		4	XE
X7	1	+24V	XF	1	+24V
	2	NC		2	NC
	3	GND		3	GND
	4	X7		4	XF

**SCHEMATIC CIRCUITRY**

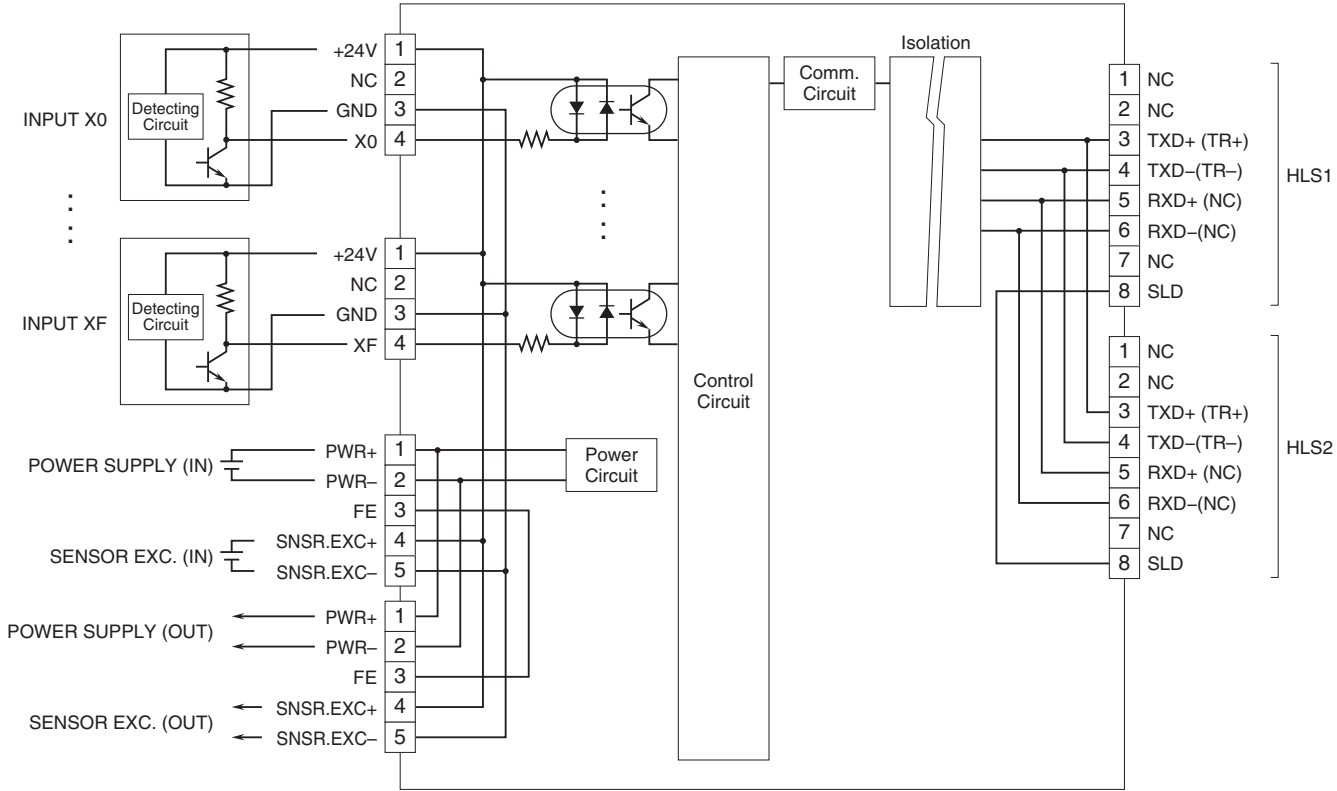

■ 2-Wire Sensor

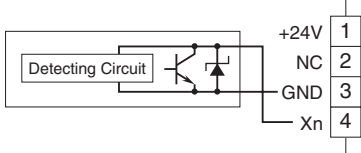

## PNP DISCRETE INPUT MODULE, 16 points

(e-CON connector)

### MODEL: R7F4DH-1-DA16B

#### SPECIFICATIONS

**Common:** Negative common (PNP) per 16 points

**Number of I/O:** Input, 16 points

**Maximum inputs applicable at once:** No limit (at 24 V DC)

**I/O status indicator:** LED turns on with closed contact.

**Isolation:** Input or sensor excitation to HLS to power input to FE

**Data allocation:** 1

**Rated input voltage:** 24 V DC  $\pm 10\%$ ; ripple 5 %p-p max.

**ON voltage / current:**  $\geq 15$  V DC (input - 0V) /  $\geq 3.5$  mA

**OFF voltage / current:**  $\leq 5$  V DC (input - 0V) /  $\leq 1$  mA

**Input current:**  $\leq 5.5$  mA per point at 24 V DC

**Input resistance:** Approx. 4.4 k $\Omega$

**ON delay:**  $\leq 0.5$  msec.

**OFF delay:**  $\leq 0.5$  msec.

#### TERMINAL ASSIGNMENTS

##### ■ Input Connection

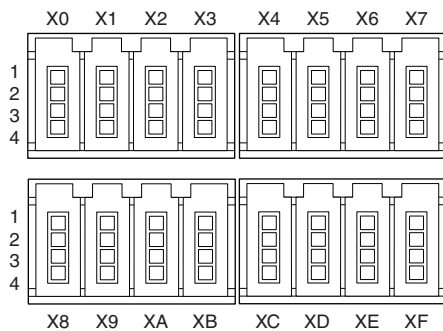

No.	ID	FUNCTION	No.	ID	FUNCTION
X0	1	+24V	X8	1	+24V
	2	NC		2	NC
	3	GND		3	GND
	4	X0		4	X8
X1	1	+24V	X9	1	+24V
	2	NC		2	NC
	3	GND		3	GND
	4	X1		4	X9
X2	1	+24V	XA	1	+24V
	2	NC		2	NC
	3	GND		3	GND
	4	X2		4	XA
X3	1	+24V	XB	1	+24V
	2	NC		2	NC
	3	GND		3	GND
	4	X3		4	XB
X4	1	+24V	XC	1	+24V
	2	NC		2	NC
	3	GND		3	GND
	4	X4		4	XC
X5	1	+24V	XD	1	+24V
	2	NC		2	NC
	3	GND		3	GND
	4	X5		4	XD
X6	1	+24V	XE	1	+24V
	2	NC		2	NC
	3	GND		3	GND
	4	X6		4	XE
X7	1	+24V	XF	1	+24V
	2	NC		2	NC
	3	GND		3	GND
	4	X7		4	XF

**SCHEMATIC CIRCUITRY**

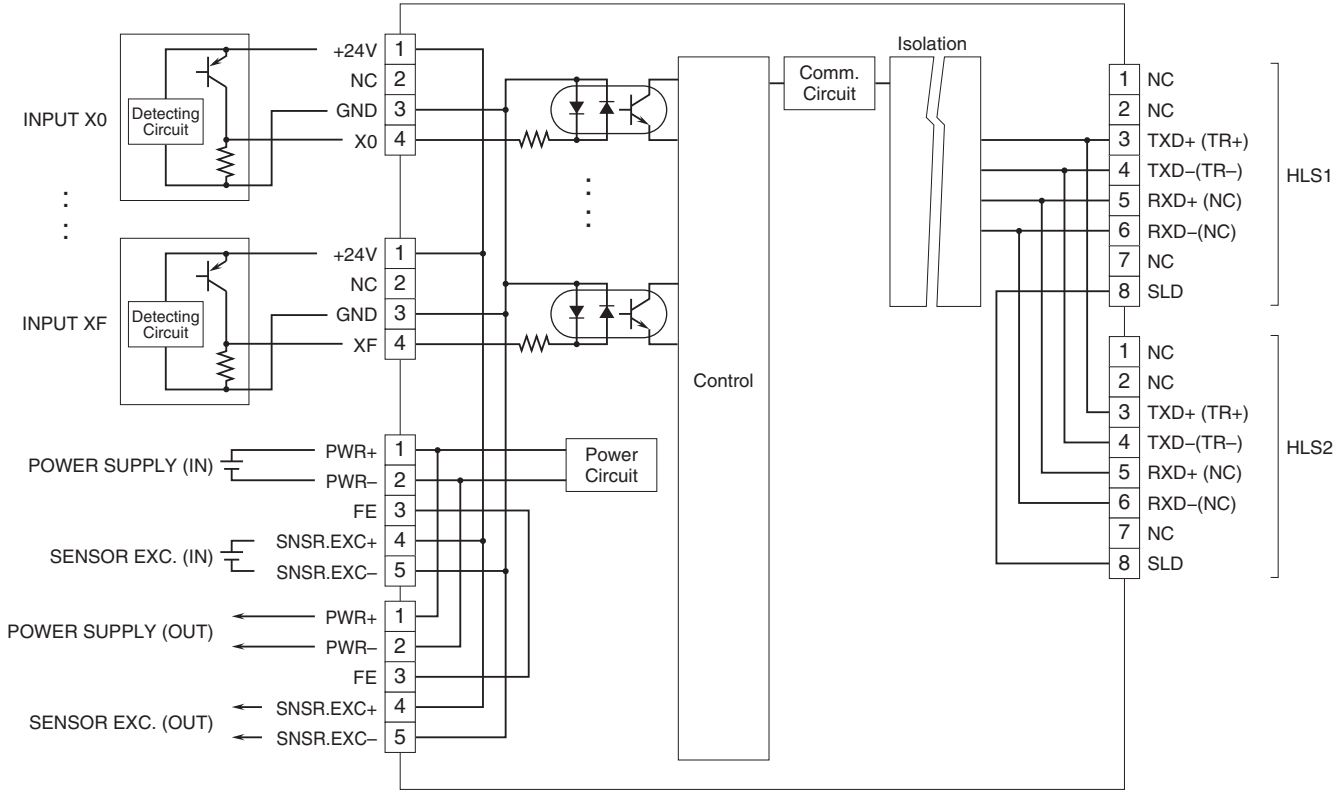

■ 2-Wire Sensor

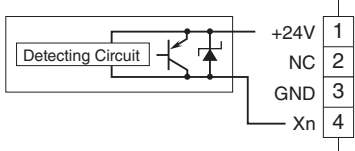

## NPN TRANSISTOR OUTPUT MODULE, 16 points

(e-CON connector)

### MODEL: R7F4DH-1-DC16A

#### SPECIFICATIONS

**Common:** Negative common (NPN) per 16 points

**Number of I/O:** Output, 16 points

**Maximum outputs applicable at once:** No limit (at 24 V DC)

**I/O status indicator:** LED turns on with closed contact.

**Isolation:** Output or sensor excitation to HLS to power input to FE

**Data allocation:** 1

**Rated load voltage:** 24 V AC  $\pm 10\%$  (ripple 5 %p-p max.)

**Rated output current:** 0.1 A per point, 1.6 A per common

**Residual voltage:**  $\leq 1.2$  V

**Leakage current:**  $\leq 0.1$  mA

**ON delay:**  $\leq 0.5$  msec.

**OFF delay:**  $\leq 0.5$  msec.

**Overload current protection function:** Limits the current value when overcurrent is detected

**Overheat Protection Function:**

Turns OFF the output when overheat is detected

#### TERMINAL ASSIGNMENTS

##### ■ Output Connection

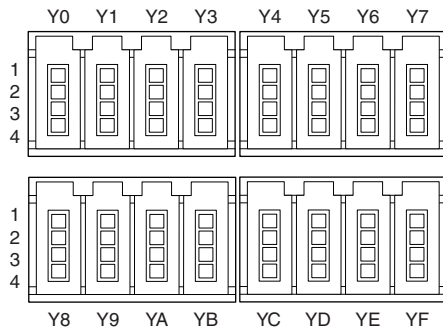

No.	ID	FUNCTION	No.	ID	FUNCTION		
Y0	1	+24V	24V DC	Y8	1	+24V	24V DC
	2	NC	Unused		2	NC	Unused
	3	GND	0V		3	GND	0V
	4	Y0	Output 0		4	Y8	Output 8
Y1	1	+24V	24V DC	Y9	1	+24V	24V DC
	2	NC	Unused		2	NC	Unused
	3	GND	0V		3	GND	0V
	4	Y1	Output 1		4	Y9	Output 9
Y2	1	+24V	24V DC	YA	1	+24V	24V DC
	2	NC	Unused		2	NC	Unused
	3	GND	0V		3	GND	0V
	4	Y2	Output 2		4	YA	Output 10
Y3	1	+24V	24V DC	YB	1	+24V	24V DC
	2	NC	Unused		2	NC	Unused
	3	GND	0V		3	GND	0V
	4	Y3	Output 3		4	YB	Output 11
Y4	1	+24V	24V DC	YC	1	+24V	24V DC
	2	NC	Unused		2	NC	Unused
	3	GND	0V		3	GND	0V
	4	Y4	Output 4		4	YC	Output 12
Y5	1	+24V	24V DC	YD	1	+24V	24V DC
	2	NC	Unused		2	NC	Unused
	3	GND	0V		3	GND	0V
	4	Y5	Output 5		4	YD	Output 13
Y6	1	+24V	24V DC	YE	1	+24V	24V DC
	2	NC	Unused		2	NC	Unused
	3	GND	0V		3	GND	0V
	4	Y6	Output 6		4	YE	Output 14
Y7	1	+24V	24V DC	YF	1	+24V	24V DC
	2	NC	Unused		2	NC	Unused
	3	GND	0V		3	GND	0V
	4	Y7	Output 7		4	YF	Output 15

**SCHEMATIC CIRCUITRY**

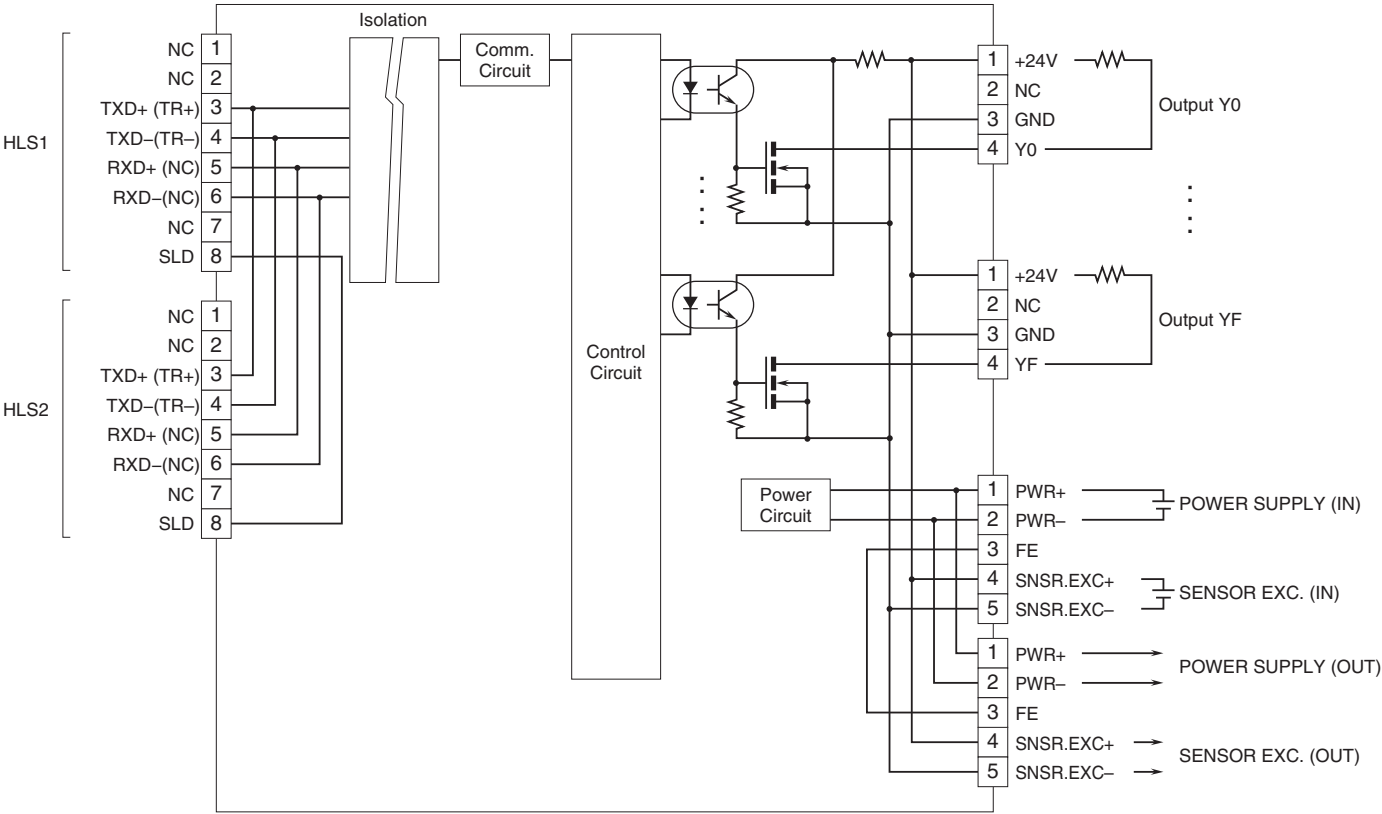

## PNP TRANSISTOR OUTPUT MODULE, 16 points

(e-CON connector)

### MODEL: R7F4DH-1-DC16B

#### SPECIFICATIONS

**Common:** Positive common (PNP) per 16 points

**Number of I/O:** Output, 16 points

**Maximum outputs applicable at once:** No limit (at 24 V DC)

**I/O status indicator:** LED turns on with closed contact.

**Isolation:** Output or sensor excitation to HLS to power input to FE

**Data allocation:** 1

**Rated load voltage:** 24 V AC  $\pm 10\%$  (ripple 5 %p-p max.)

**Rated output current:** 0.1 A per point, 1.6 A per common

**Residual voltage:**  $\leq 1.2$  V

**Leakage current:**  $\leq 0.1$  mA

**ON delay:**  $\leq 0.5$  msec.

**OFF delay:**  $\leq 0.5$  msec.

**Overload current protection function:** Limits the current value when overcurrent is detected

**Overheat Protection Function:**

Turns OFF the output when overheat is detected

#### TERMINAL ASSIGNMENTS

##### ■ Output Connection

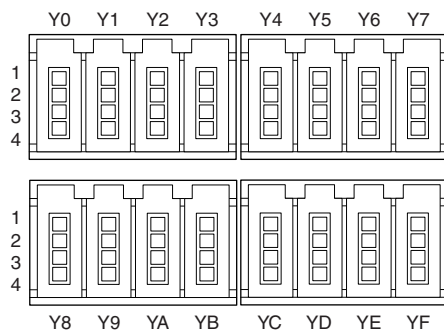

No.	ID	FUNCTION	No.	ID	FUNCTION		
Y0	1	+24V	24V DC	Y8	1	+24V	24V DC
	2	NC	Unused		2	NC	Unused
	3	GND	0V		3	GND	0V
	4	Y0	Output 0		4	Y8	Output 8
Y1	1	+24V	24V DC	Y9	1	+24V	24V DC
	2	NC	Unused		2	NC	Unused
	3	GND	0V		3	GND	0V
	4	Y1	Output 1		4	Y9	Output 9
Y2	1	+24V	24V DC	YA	1	+24V	24V DC
	2	NC	Unused		2	NC	Unused
	3	GND	0V		3	GND	0V
	4	Y2	Output 2		4	YA	Output 10
Y3	1	+24V	24V DC	YB	1	+24V	24V DC
	2	NC	Unused		2	NC	Unused
	3	GND	0V		3	GND	0V
	4	Y3	Output 3		4	YB	Output 11
Y4	1	+24V	24V DC	YC	1	+24V	24V DC
	2	NC	Unused		2	NC	Unused
	3	GND	0V		3	GND	0V
	4	Y4	Output 4		4	YC	Output 12
Y5	1	+24V	24V DC	YD	1	+24V	24V DC
	2	NC	Unused		2	NC	Unused
	3	GND	0V		3	GND	0V
	4	Y5	Output 5		4	YD	Output 13
Y6	1	+24V	24V DC	YE	1	+24V	24V DC
	2	NC	Unused		2	NC	Unused
	3	GND	0V		3	GND	0V
	4	Y6	Output 6		4	YE	Output 14
Y7	1	+24V	24V DC	YF	1	+24V	24V DC
	2	NC	Unused		2	NC	Unused
	3	GND	0V		3	GND	0V
	4	Y7	Output 7		4	YF	Output 15

**SCHEMATIC CIRCUITRY**

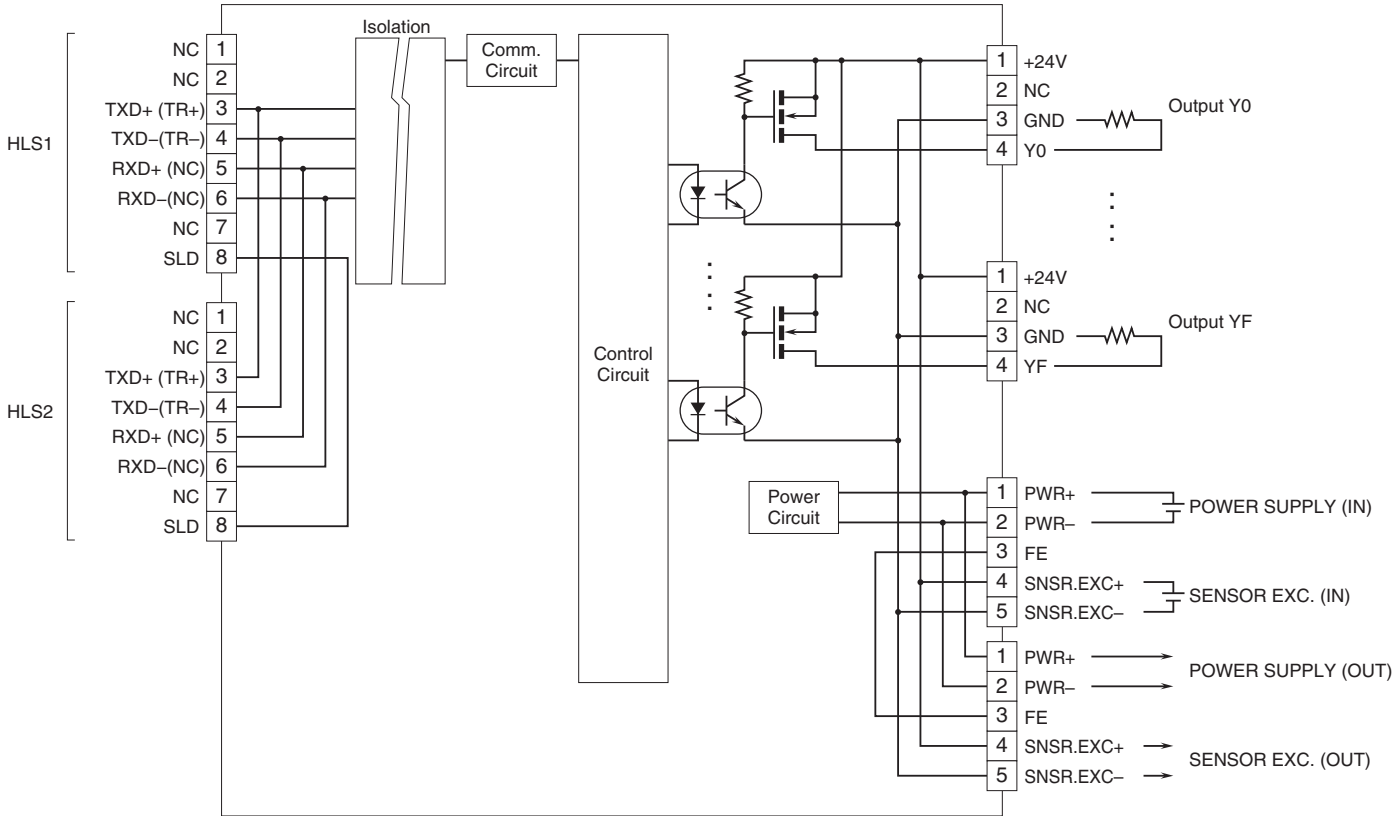

**PNP DISCRETE INPUT &  
NPN TRANSISTOR OUTPUT MODULE, 8 points each**  
(e-CON connector)

**MODEL: R7F4DH-1-DAC16A**

**SPECIFICATIONS**

■ COMMON SPECIFICATIONS

- Common: Negative common per 16 points
- Input rating/load voltage: 24 V DC  $\pm 10\%$ , ripple 5 %p-p max.
- Number of I/O: Input, 8 points; Output, 8 points
- Maximum I/O applicable at once: No limit (at 24 V DC)
- I/O status indicator: LED turns on with closed contact.
- Isolation: I/O or sensor excitation to HLS to power input to FE
- Data allocation: 1
- INPUT
- ON voltage / current:  $\geq 15$  V DC (I/O's X0 through X7 to 0 V) /  $\geq 3.5$  mA
- OFF voltage / current:  $\leq 5$  V DC (I/O's X0 through X7 to 0 V) /  $\leq 1$  mA
- Input current:  $\leq 5.5$  mA per point at 24 V DC
- Input resistance: Approx. 4.4 k $\Omega$
- ON delay:  $\leq 0.5$  msec.
- OFF delay:  $\leq 0.5$  msec.
- OUTPUT
- Rated output current: 0.1 A per point, 0.8 A per common
- Residual voltage:  $\leq 1.2$  V
- Leakage current:  $\leq 0.1$  mA
- ON delay:  $\leq 0.5$  msec.
- OFF delay:  $\leq 0.5$  msec.
- Overload current protection function: Limits the current value when overcurrent is detected
- Overheat Protection Function:  
Turns OFF the output when overheat is detected

No.	ID	FUNCTION	No.	ID	FUNCTION
X0	1	+24V 24V DC	Y0	1	+24V 24V DC
	2	NC Unused		2	NC Unused
	3	GND 0V		3	GND 0V
	4	X0 Input 0		4	Y0 Output 0
X1	1	+24V 24V DC	Y1	1	+24V 24V DC
	2	NC Unused		2	NC Unused
	3	GND 0V		3	GND 0V
	4	X1 Input 1		4	Y1 Output 1
X2	1	+24V 24V DC	Y2	1	+24V 24V DC
	2	NC Unused		2	NC Unused
	3	GND 0V		3	GND 0V
	4	X2 Input 2		4	Y2 Output 2
X3	1	+24V 24V DC	Y3	1	+24V 24V DC
	2	NC Unused		2	NC Unused
	3	GND 0V		3	GND 0V
	4	X3 Input 3		4	Y3 Output 3
X4	1	+24V 24V DC	Y4	1	+24V 24V DC
	2	NC Unused		2	NC Unused
	3	GND 0V		3	GND 0V
	4	X4 Input 4		4	Y4 Output 4
X5	1	+24V 24V DC	Y5	1	+24V 24V DC
	2	NC Unused		2	NC Unused
	3	GND 0V		3	GND 0V
	4	X5 Input 5		4	Y5 Output 5
X6	1	+24V 24V DC	Y6	1	+24V 24V DC
	2	NC Unused		2	NC Unused
	3	GND 0V		3	GND 0V
	4	X6 Input 6		4	Y6 Output 6
X7	1	+24V 24V DC	Y7	1	+24V 24V DC
	2	NC Unused		2	NC Unused
	3	GND 0V		3	GND 0V
	4	X7 Input 7		4	Y7 Output 7

**TERMINAL ASSIGNMENTS**

■ I/O Connection

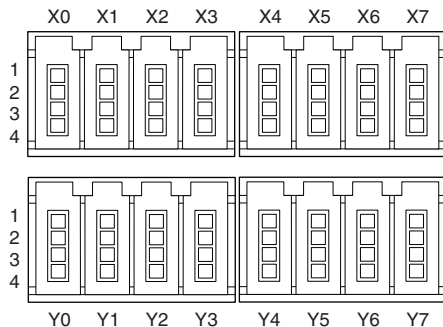

**SCHEMATIC CIRCUITRY**

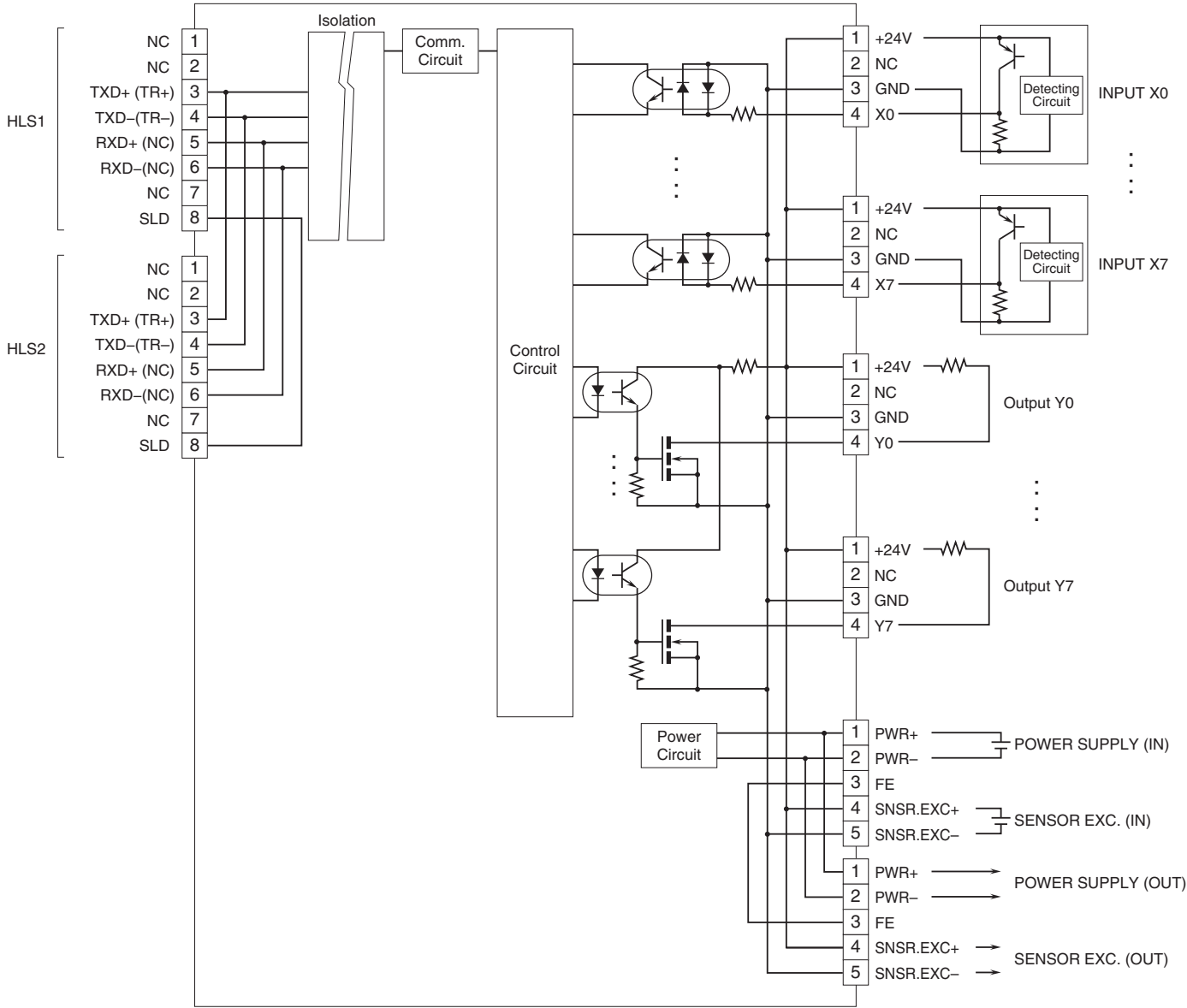

■ 2-Wire Sensor

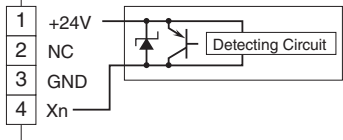

**NPN DISCRETE INPUT & PNP TRANSISTOR OUTPUT MODULE, 8 points each**  
(e-CON connector)

**MODEL: R7F4DH-1-DAC16B**

**SPECIFICATIONS**

■ COMMON SPECIFICATIONS

- Common: Positive common per 16 points
- Input rating/load voltage: 24 V DC  $\pm 10\%$ , ripple 5 %p-p max.
- Number of I/O: Input, 8 points; Output, 8 points
- Maximum I/O applicable at once: No limit (at 24 V DC)
- I/O status indicator: LED turns on with closed contact.
- Isolation: I/O or sensor excitation to HLS to power input to FE
- Data allocation: 1
- INPUT
- ON voltage / current:  $\geq 15$  V DC (I/O's X0 through X7 to +24 V) /  $\geq 3.5$  mA
- OFF voltage / current:  $\leq 5$  V DC (I/O's X0 through X7 to +24 V) /  $\leq 1$  mA
- Input current:  $\leq 5.5$  mA per point at 24 V DC
- Input resistance: Approx. 4.4 k $\Omega$
- ON delay:  $\leq 0.5$  msec.
- OFF delay:  $\leq 0.5$  msec.
- OUTPUT
- Rated output current: 0.1 A per point, 0.8 A per common
- Residual voltage:  $\leq 1.2$  V
- Leakage current:  $\leq 0.1$  mA
- ON delay:  $\leq 0.5$  msec.
- OFF delay:  $\leq 0.5$  msec.
- Overload current protection function: Limits the current value when overcurrent is detected
- Overheat Protection Function:  
Turns OFF the output when overheat is detected

No.	ID	FUNCTION	No.	ID	FUNCTION
X0	1	+24V 24V DC	Y0	1	+24V 24V DC
	2	NC Unused		2	NC Unused
	3	GND 0V		3	GND 0V
	4	X0 Input 0		4	Y0 Output 0
X1	1	+24V 24V DC	Y1	1	+24V 24V DC
	2	NC Unused		2	NC Unused
	3	GND 0V		3	GND 0V
	4	X1 Input 1		4	Y1 Output 1
X2	1	+24V 24V DC	Y2	1	+24V 24V DC
	2	NC Unused		2	NC Unused
	3	GND 0V		3	GND 0V
	4	X2 Input 2		4	Y2 Output 2
X3	1	+24V 24V DC	Y3	1	+24V 24V DC
	2	NC Unused		2	NC Unused
	3	GND 0V		3	GND 0V
	4	X3 Input 3		4	Y3 Output 3
X4	1	+24V 24V DC	Y4	1	+24V 24V DC
	2	NC Unused		2	NC Unused
	3	GND 0V		3	GND 0V
	4	X4 Input 4		4	Y4 Output 4
X5	1	+24V 24V DC	Y5	1	+24V 24V DC
	2	NC Unused		2	NC Unused
	3	GND 0V		3	GND 0V
	4	X5 Input 5		4	Y5 Output 5
X6	1	+24V 24V DC	Y6	1	+24V 24V DC
	2	NC Unused		2	NC Unused
	3	GND 0V		3	GND 0V
	4	X6 Input 6		4	Y6 Output 6
X7	1	+24V 24V DC	Y7	1	+24V 24V DC
	2	NC Unused		2	NC Unused
	3	GND 0V		3	GND 0V
	4	X7 Input 7		4	Y7 Output 7

**TERMINAL ASSIGNMENTS**

■ I/O Connection

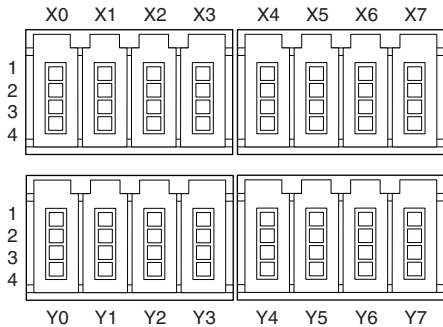

**SCHEMATIC CIRCUITRY**

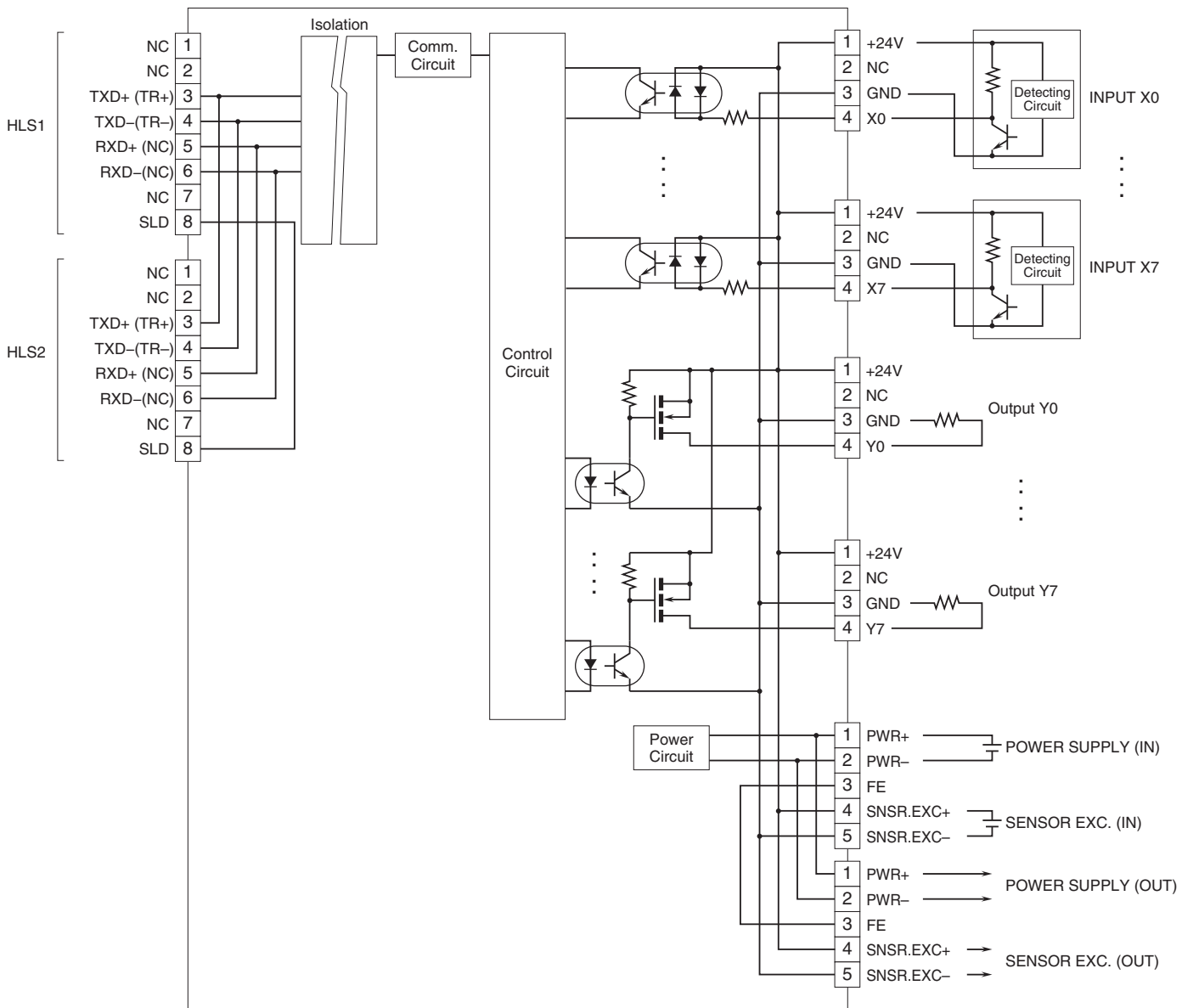

■ 2-Wire Sensor

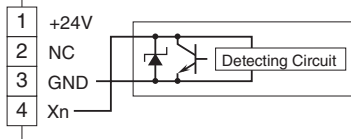

## NPN DISCRETE INPUT & NPN TRANSISTOR OUTPUT MODULE, 8 points each (e-CON connector)

### MODEL: R7F4DH-1-DAC16C

#### SPECIFICATIONS

##### COMMON SPECIFICATIONS

**Input common:** Positive common per 8 points

**Output common:** Negative common per 8 points

**Input rating/load voltage:** 24 V DC  $\pm 10\%$ , ripple 5 %p-p max.

**Number of I/O:** Input, 8 points; Output, 8 points

**Maximum I/O applicable at once:** No limit (at 24 V DC)

**I/O status indicator:** LED turns on with closed contact.

**Isolation:** I/O or sensor excitation to HLS to power input to FE

**Data allocation:** 1

##### INPUT

**ON voltage / current:**  $\geq 15$  V DC (I/O's X0 through X7 to +24 V) /  $\geq 3.5$  mA

**OFF voltage / current:**  $\leq 5$  V DC (I/O's X0 through X7 to +24 V) /  $\leq 1$  mA

**Input current:**  $\leq 5.5$  mA per point at 24 V DC

**Input resistance:** Approx. 4.4 k $\Omega$

**ON delay:**  $\leq 0.5$  msec.

**OFF delay:**  $\leq 0.5$  msec.

##### OUTPUT

**Rated output current:** 0.1 A per point, 0.8 A per common

**Residual voltage:**  $\leq 1.2$  V

**Leakage current:**  $\leq 0.1$  mA

**ON delay:**  $\leq 0.5$  msec.

**OFF delay:**  $\leq 0.5$  msec.

**Overload current protection function:** Limits the current value when overcurrent is detected

**Overheat Protection Function:**

Turns OFF the output when overheat is detected

No.	ID	FUNCTION	No.	ID	FUNCTION
X0	1	+24V 24V DC	Y0	1	+24V 24V DC
	2	NC Unused		2	NC Unused
	3	GND 0V		3	GND 0V
	4	X0 Input 0		4	Y0 Output 0
X1	1	+24V 24V DC	Y1	1	+24V 24V DC
	2	NC Unused		2	NC Unused
	3	GND 0V		3	GND 0V
	4	X1 Input 1		4	Y1 Output 1
X2	1	+24V 24V DC	Y2	1	+24V 24V DC
	2	NC Unused		2	NC Unused
	3	GND 0V		3	GND 0V
	4	X2 Input 2		4	Y2 Output 2
X3	1	+24V 24V DC	Y3	1	+24V 24V DC
	2	NC Unused		2	NC Unused
	3	GND 0V		3	GND 0V
	4	X3 Input 3		4	Y3 Output 3
X4	1	+24V 24V DC	Y4	1	+24V 24V DC
	2	NC Unused		2	NC Unused
	3	GND 0V		3	GND 0V
	4	X4 Input 4		4	Y4 Output 4
X5	1	+24V 24V DC	Y5	1	+24V 24V DC
	2	NC Unused		2	NC Unused
	3	GND 0V		3	GND 0V
	4	X5 Input 5		4	Y5 Output 5
X6	1	+24V 24V DC	Y6	1	+24V 24V DC
	2	NC Unused		2	NC Unused
	3	GND 0V		3	GND 0V
	4	X6 Input 6		4	Y6 Output 6
X7	1	+24V 24V DC	Y7	1	+24V 24V DC
	2	NC Unused		2	NC Unused
	3	GND 0V		3	GND 0V
	4	X7 Input 7		4	Y7 Output 7

#### TERMINAL ASSIGNMENTS

##### I/O Connection

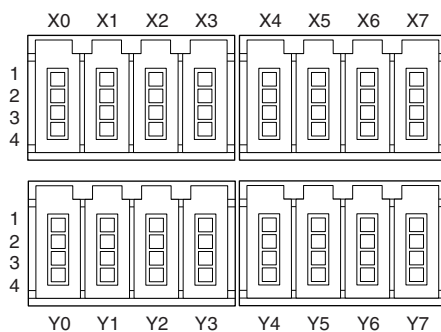

**SCHEMATIC CIRCUITRY**

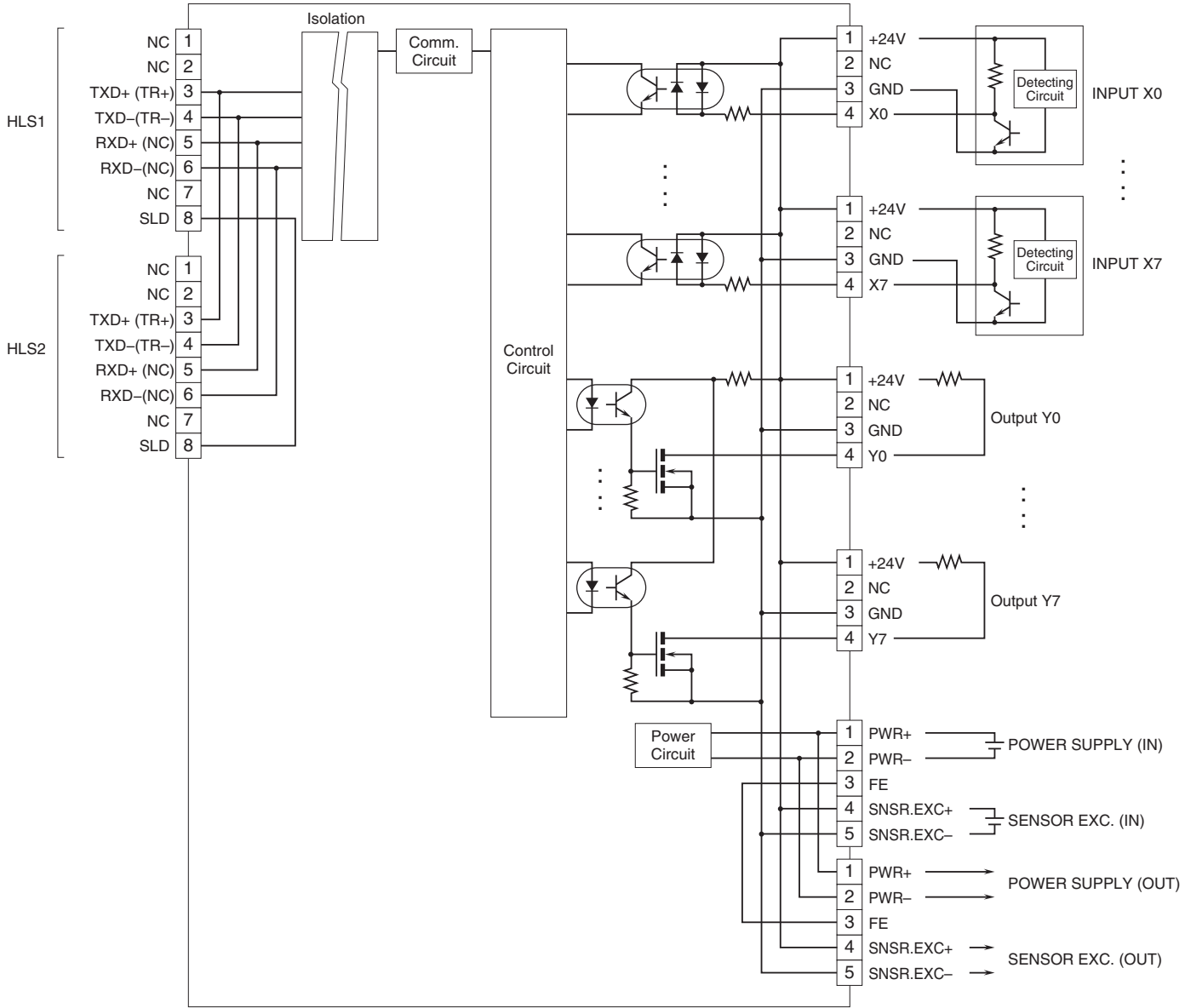

■ 2-Wire Sensor

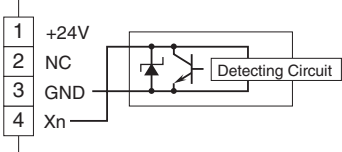

## PNP DISCRETE INPUT & PNP TRANSISTOR OUTPUT MODULE, 8 points each (e-CON connector)

### MODEL: R7F4DH-1-DAC16D

#### SPECIFICATIONS

##### COMMON SPECIFICATIONS

- Input common:** Negative common per 8 points
- Output common:** Positive common per 8 points
- Input rating/load voltage:** 24 V DC  $\pm 10\%$ , ripple 5 %p-p max.
- Number of I/O:** Input, 8 points; Output, 8 points
- Maximum I/O applicable at once:** No limit (at 24 V DC)
- I/O status indicator:** LED turns on with closed contact.
- Isolation:** I/O or sensor excitation to HLS to power input to FE
- Data allocation:** 1
- ##### INPUT

  - ON voltage / current:**  $\geq 15$  V DC (I/O's X0 through X7 to 0 V) /  $\geq 3.5$  mA
  - OFF voltage / current:**  $\leq 5$  V DC (I/O's X0 through X7 to 0 V) /  $\leq 1$  mA
  - Input current:**  $\leq 5.5$  mA per point at 24 V DC
  - Input resistance:** Approx. 4.4 k $\Omega$
  - ON delay:**  $\leq 0.5$  msec.
  - OFF delay:**  $\leq 0.5$  msec.
- ##### OUTPUT

  - Rated output current:** 0.1 A per point, 0.8 A per common
  - Residual voltage:**  $\leq 1.2$  V
  - Leakage current:**  $\leq 0.1$  mA
  - ON delay:**  $\leq 0.5$  msec.
  - OFF delay:**  $\leq 0.5$  msec.
  - Overload current protection function:** Limits the current value when overcurrent is detected
  - Overheat Protection Function:** Turns OFF the output when overheat is detected

No.	ID	FUNCTION	No.	ID	FUNCTION
X0	1	+24V 24V DC	Y0	1	+24V 24V DC
	2	NC Unused		2	NC Unused
	3	GND 0V		3	GND 0V
	4	X0 Input 0		4	Y0 Output 0
X1	1	+24V 24V DC	Y1	1	+24V 24V DC
	2	NC Unused		2	NC Unused
	3	GND 0V		3	GND 0V
	4	X1 Input 1		4	Y1 Output 1
X2	1	+24V 24V DC	Y2	1	+24V 24V DC
	2	NC Unused		2	NC Unused
	3	GND 0V		3	GND 0V
	4	X2 Input 2		4	Y2 Output 2
X3	1	+24V 24V DC	Y3	1	+24V 24V DC
	2	NC Unused		2	NC Unused
	3	GND 0V		3	GND 0V
	4	X3 Input 3		4	Y3 Output 3
X4	1	+24V 24V DC	Y4	1	+24V 24V DC
	2	NC Unused		2	NC Unused
	3	GND 0V		3	GND 0V
	4	X4 Input 4		4	Y4 Output 4
X5	1	+24V 24V DC	Y5	1	+24V 24V DC
	2	NC Unused		2	NC Unused
	3	GND 0V		3	GND 0V
	4	X5 Input 5		4	Y5 Output 5
X6	1	+24V 24V DC	Y6	1	+24V 24V DC
	2	NC Unused		2	NC Unused
	3	GND 0V		3	GND 0V
	4	X6 Input 6		4	Y6 Output 6
X7	1	+24V 24V DC	Y7	1	+24V 24V DC
	2	NC Unused		2	NC Unused
	3	GND 0V		3	GND 0V
	4	X7 Input 7		4	Y7 Output 7

#### TERMINAL ASSIGNMENTS

##### I/O Connection

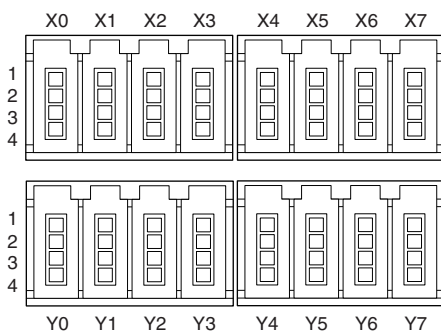

**SCHEMATIC CIRCUITRY**

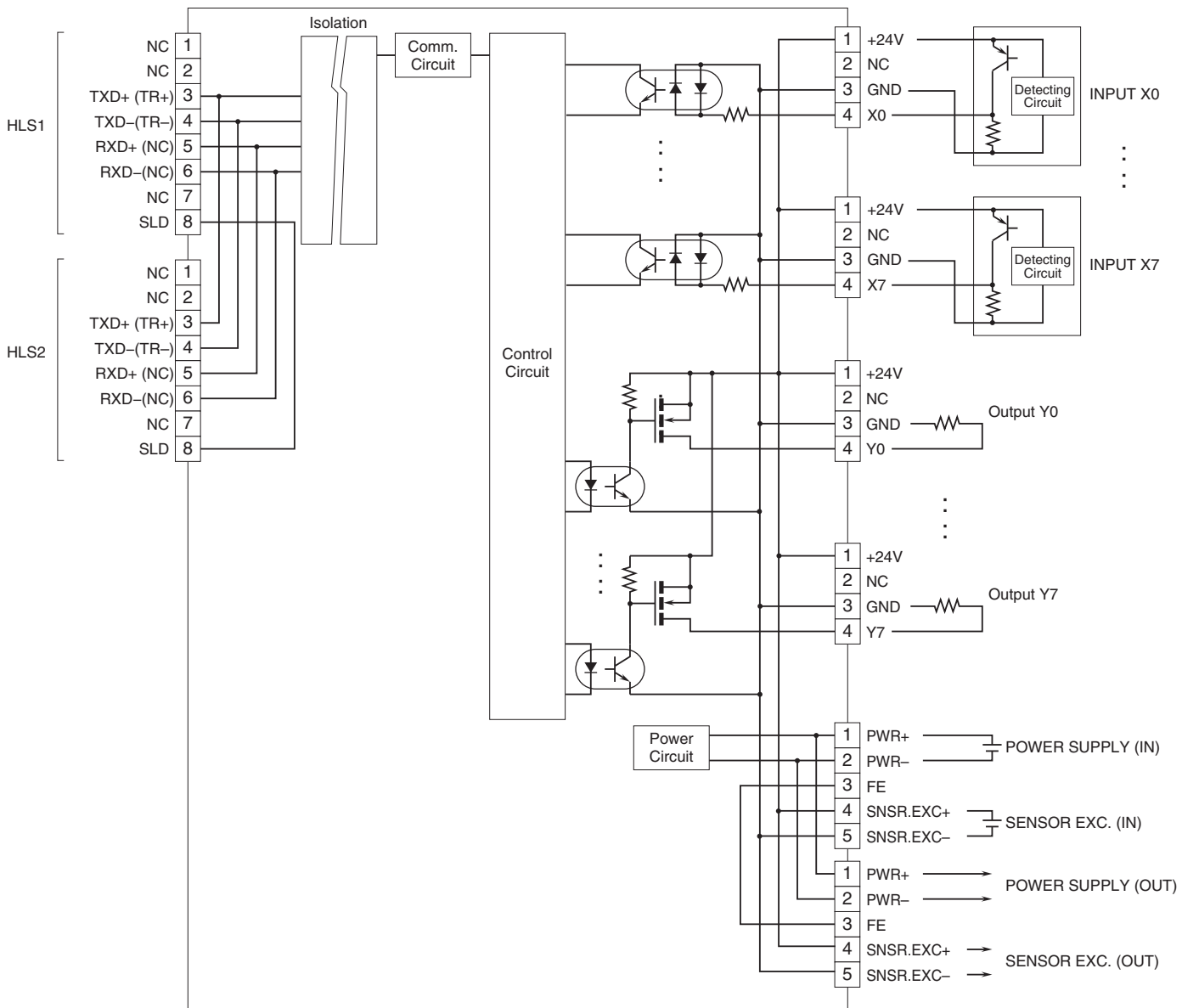

■ 2-Wire Sensor

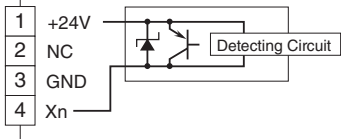

## NPN DISCRETE INPUT MODULE, 16 points

(MIL connector)

### MODEL:

**R7F4DH-2-DA16A**

**R7F4DH-3-DA16A**

### SPECIFICATIONS

**Common:** Positive common (NPN) per 16 points

**Number of I/O:** Input, 16 points

**Maximum inputs applicable at once:** No limit (at 24 V DC)

**I/O status indicator:** LED turns on with closed contact.

**Isolation:** Input or sensor excitation to HLS to power input to FE

**Data allocation:** 1

**Rated input voltage:** 24 V DC  $\pm 10\%$ ; ripple 5 %p-p max.

**ON voltage / current:**  $\geq 15$  V DC (input - +24V) /  $\geq 3.5$  mA

**OFF voltage / current:**  $\leq 5$  V DC (input - +24V) /  $\leq 1$  mA

**Input current:**  $\leq 5.5$  mA per point at 24 V DC

**Input resistance:** Approx. 4.4 k $\Omega$

**ON delay:**  $\leq 0.5$  msec.

**OFF delay:**  $\leq 0.5$  msec.

### TERMINAL ASSIGNMENTS

#### ■ Input Connection

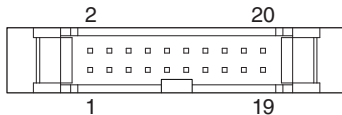

#### 1. Terminal block code 2

PIN No	ID	FUNCTION	PIN No	ID	FUNCTION
1	X0	Input 0	11	XA	Input 10
2	X1	Input 1	12	XB	Input 11
3	X2	Input 2	13	XC	Input 12
4	X3	Input 3	14	XD	Input 13
5	X4	Input 4	15	XE	Input 14
6	X5	Input 5	16	XF	Input 15
7	X6	Input 6	17	GND	0V
8	X7	Input 7	18	GND	0V
9	X8	Input 8	19	+24V	24VDC
10	X9	Input 9	20	+24V	24VDC

#### 2. Terminal block code 3

PIN No	ID	FUNCTION	PIN No	ID	FUNCTION
1	+24V	24VDC	11	XC	Input 12
2	+24V	24VDC	12	X4	Input 4
3	GND	0V	13	XB	Input 11
4	GND	0V	14	X3	Input 3
5	XF	Input 15	15	XA	Input 10
6	X7	Input 7	16	X2	Input 2
7	XE	Input 14	17	X9	Input 9
8	X6	Input 6	18	X1	Input 1
9	XD	Input 13	19	X8	Input 8
10	X5	Input 5	20	X0	Input 0

**SCHEMATIC CIRCUITRY**

■ TERMINAL CODE 2

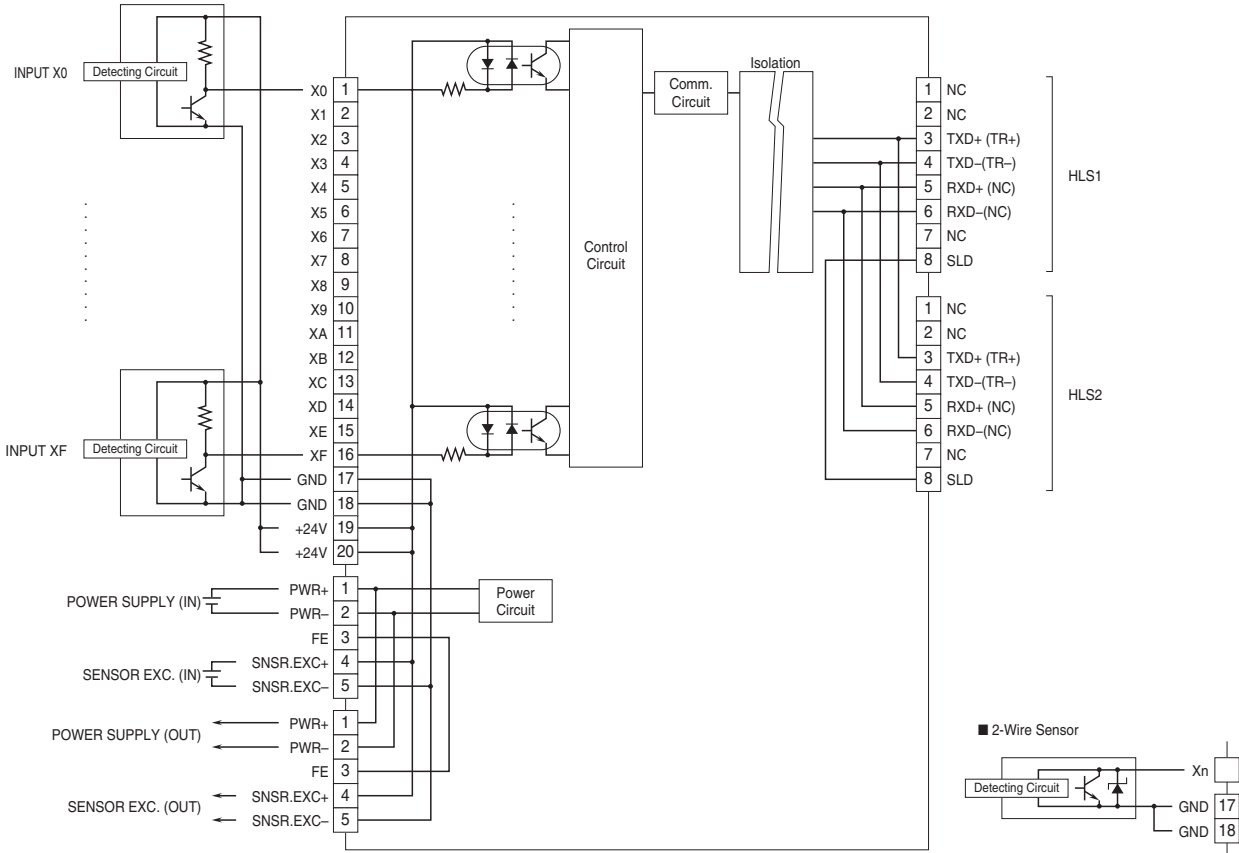

■ TERMINAL CODE 3

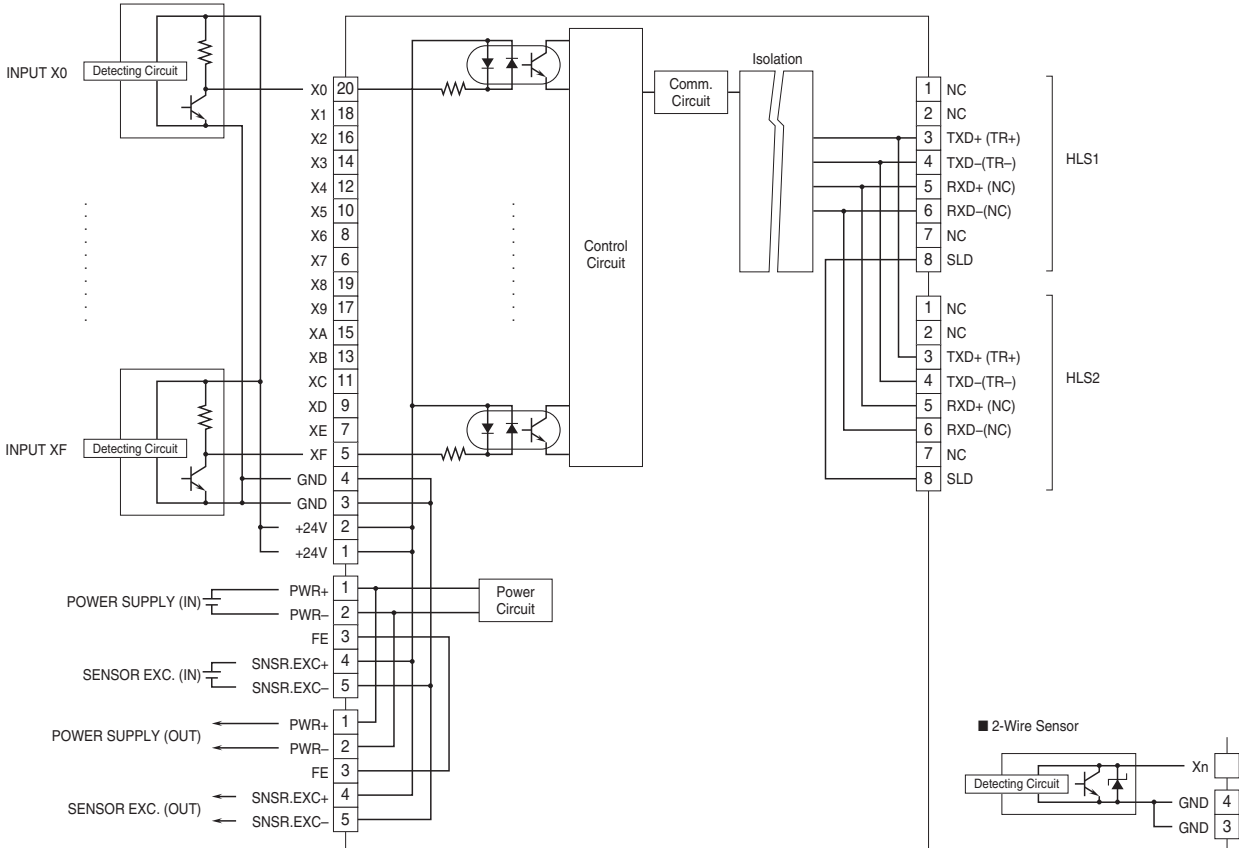

## PNP DISCRETE INPUT MODULE, 16 points

(MIL connector)

### MODEL:

**R7F4DH-2-DA16B**

**R7F4DH-3-DA16B**

### SPECIFICATIONS

**Common:** Negative common (PNP) per 16 points

**Number of I/O:** Input, 16 points

**Maximum inputs applicable at once:** No limit (at 24 V DC)

**I/O status indicator:** LED turns on with closed contact.

**Isolation:** Input or sensor excitation to HLS to power input to FE

**Data allocation:** 1

**Rated input voltage:** 24 V DC  $\pm 10\%$ ; ripple 5 %p-p max.

**ON voltage / current:**  $\geq 15$  V DC (input - 0V) /  $\geq 3.5$  mA

**OFF voltage / current:**  $\leq 5$  V DC (input - 0V) /  $\leq 1$  mA

**Input current:**  $\leq 5.5$  mA per point at 24 V DC

**Input resistance:** Approx. 4.4 k $\Omega$

**ON delay:**  $\leq 0.5$  msec.

**OFF delay:**  $\leq 0.5$  msec.

### TERMINAL ASSIGNMENTS

#### ■ Input Connection

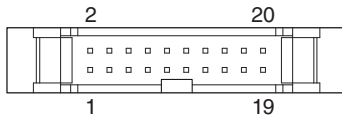

#### 1. Terminal block code 2

PIN No	ID	FUNCTION	PIN No	ID	FUNCTION
1	X0	Input 0	11	XA	Input 10
2	X1	Input 1	12	XB	Input 11
3	X2	Input 2	13	XC	Input 12
4	X3	Input 3	14	XD	Input 13
5	X4	Input 4	15	XE	Input 14
6	X5	Input 5	16	XF	Input 15
7	X6	Input 6	17	GND	0V
8	X7	Input 7	18	GND	0V
9	X8	Input 8	19	+24V	24VDC
10	X9	Input 9	20	+24V	24VDC

#### 2. Terminal block code 3

PIN No	ID	FUNCTION	PIN No	ID	FUNCTION
1	+24V	24VDC	11	XC	Input 12
2	+24V	24VDC	12	X4	Input 4
3	GND	0V	13	XB	Input 11
4	GND	0V	14	X3	Input 3
5	XF	Input 15	15	XA	Input 10
6	X7	Input 7	16	X2	Input 2
7	XE	Input 14	17	X9	Input 9
8	X6	Input 6	18	X1	Input 1
9	XD	Input 13	19	X8	Input 8
10	X5	Input 5	20	X0	Input 0

**SCHEMATIC CIRCUITRY**

■ TERMINAL CODE 2

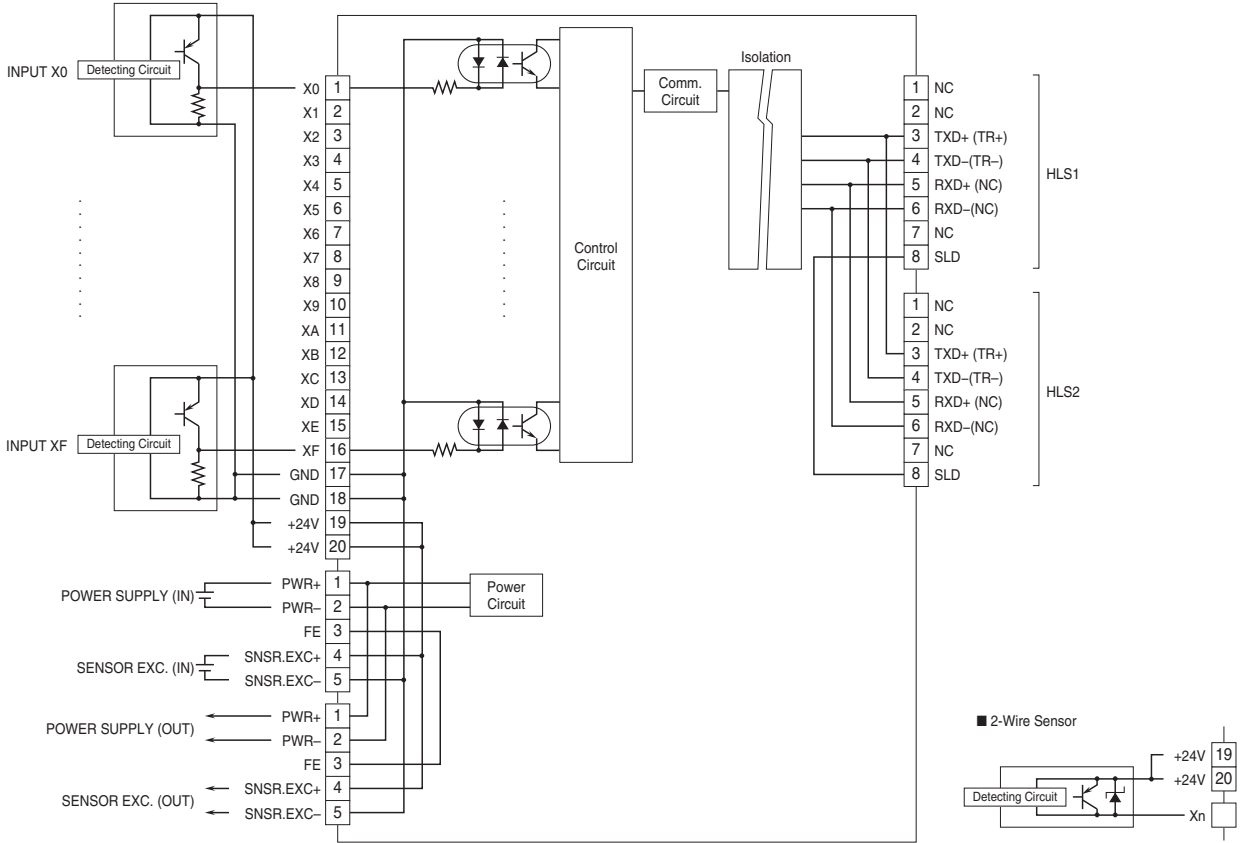

■ TERMINAL CODE 3

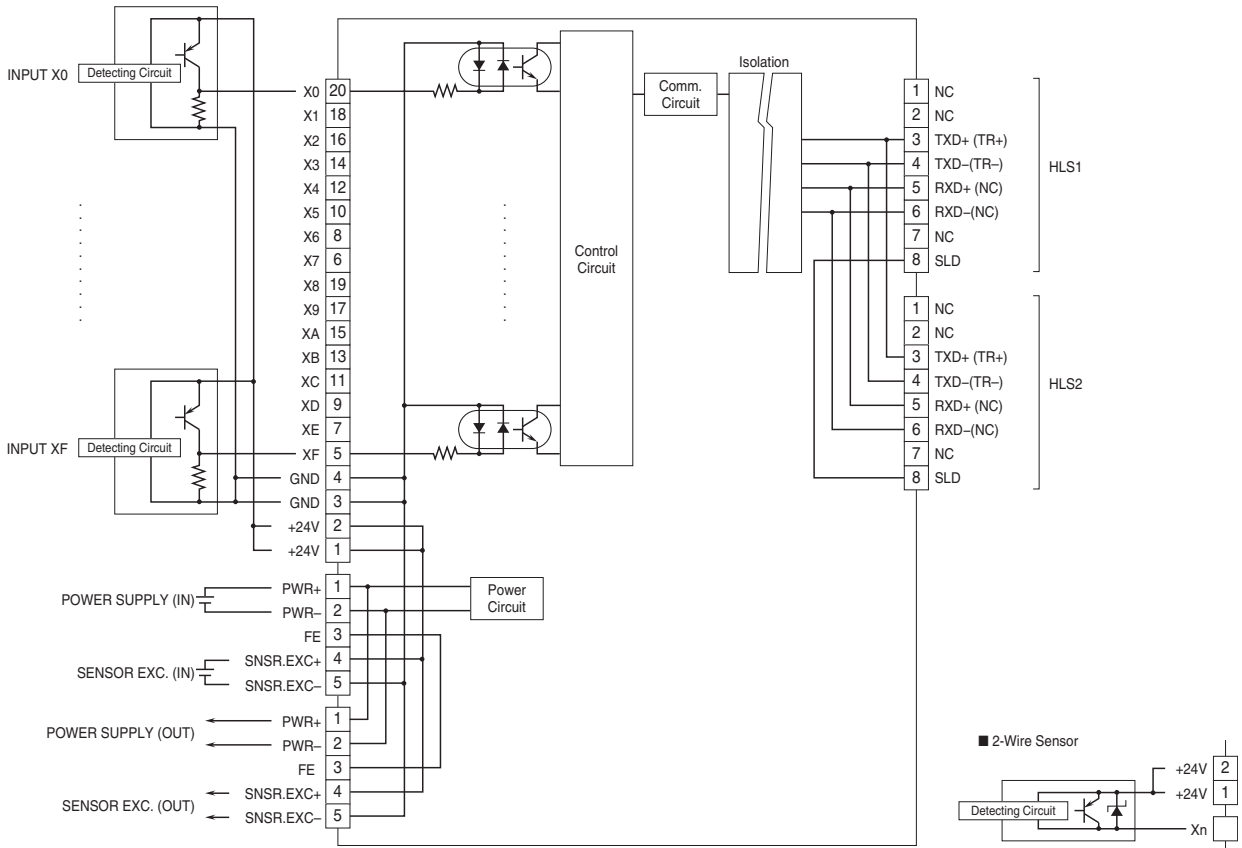

## NPN TRANSISTOR OUTPUT MODULE, 16 points

(MIL connector)

### MODEL:

**R7F4DH-2-DC16A**

**R7F4DH-3-DC16A**

### SPECIFICATIONS

**Common:** Negative common (NPN) per 16 points

**Number of I/O:** Output, 16 points

**Maximum outputs applicable at once:** No limit (at 24 V DC)

**I/O status indicator:** LED turns on with closed contact.

**Isolation:** Output or sensor excitation to HLS to power input to FE

**Data allocation:** 1

**Rated load voltage:** 24 V AC  $\pm 10\%$  (ripple 5 %p-p max.)

**Rated output current:** 0.1 A per point, 1.6 A per common

**Residual voltage:**  $\leq 1.2$  V

**Leakage current:**  $\leq 0.1$  mA

**ON delay:**  $\leq 0.5$  msec.

**OFF delay:**  $\leq 0.5$  msec.

**Overload current protection function:** Limits the current value when overcurrent is detected

**Overheat Protection Function:**

Turns OFF the output when overheat is detected

### TERMINAL ASSIGNMENTS

#### ■ Output Connection

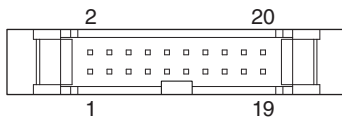

#### 1. Terminal block code 2

PIN No	ID	FUNCTION	PIN No	ID	FUNCTION
1	Y0	Output 0	11	YA	Output 10
2	Y1	Output 1	12	YB	Output 11
3	Y2	Output 2	13	YC	Output 12
4	Y3	Output 3	14	YD	Output 13
5	Y4	Output 4	15	YE	Output 14
6	Y5	Output 5	16	YF	Output 15
7	Y6	Output 6	17	GND	0V
8	Y7	Output 7	18	GND	0V
9	Y8	Output 8	19	+24V	24VDC
10	Y9	Output 9	20	+24V	24VDC

#### 2. Terminal block code 3

PIN No	ID	FUNCTION	PIN No	ID	FUNCTION
1	+24V	24VDC	11	YC	Output 12
2	+24V	24VDC	12	Y4	Output 4
3	GND	0V	13	YB	Output 11
4	GND	0V	14	Y3	Output 3
5	YF	Output 15	15	YA	Output 10
6	Y7	Output 7	16	Y2	Output 2
7	YE	Output 14	17	Y9	Output 9
8	Y6	Output 6	18	Y1	Output 1
9	YD	Output 13	19	Y8	Output 8
10	Y5	Output 5	20	Y0	Output 0

**SCHEMATIC CIRCUITRY**

■ TERMINAL CODE 2

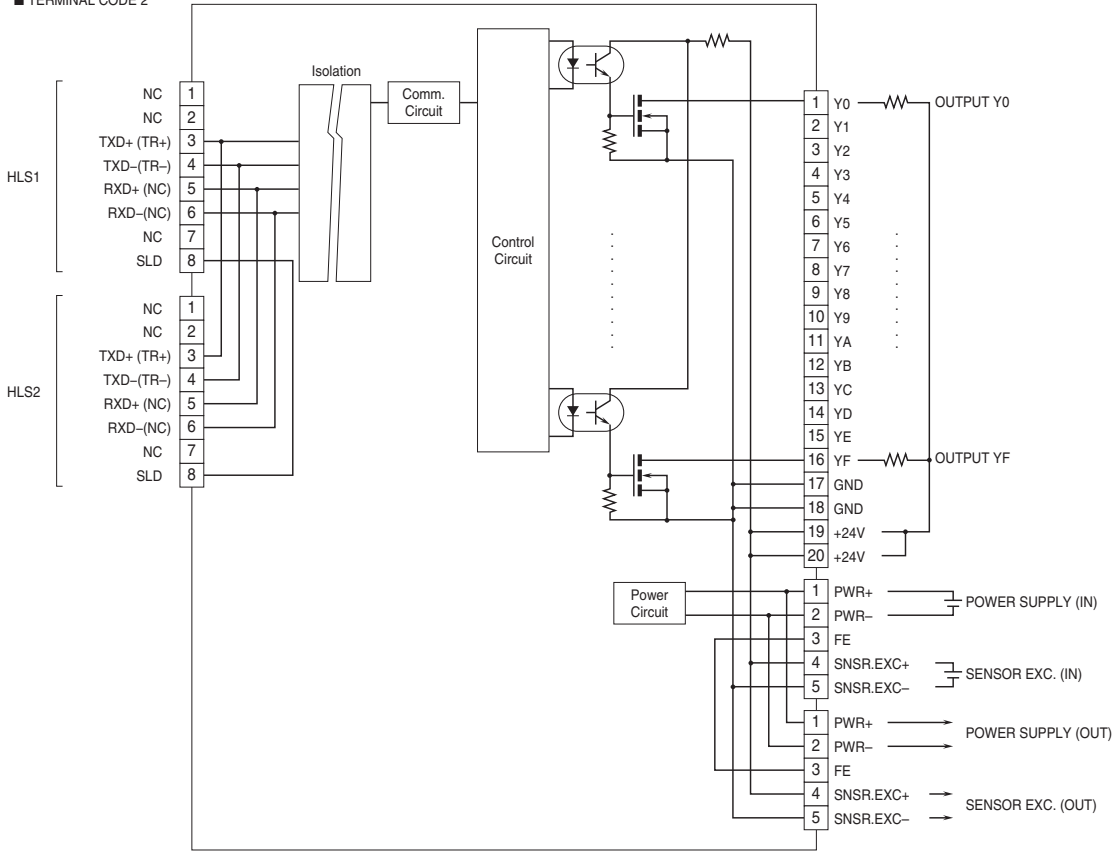

■ TERMINAL CODE 3

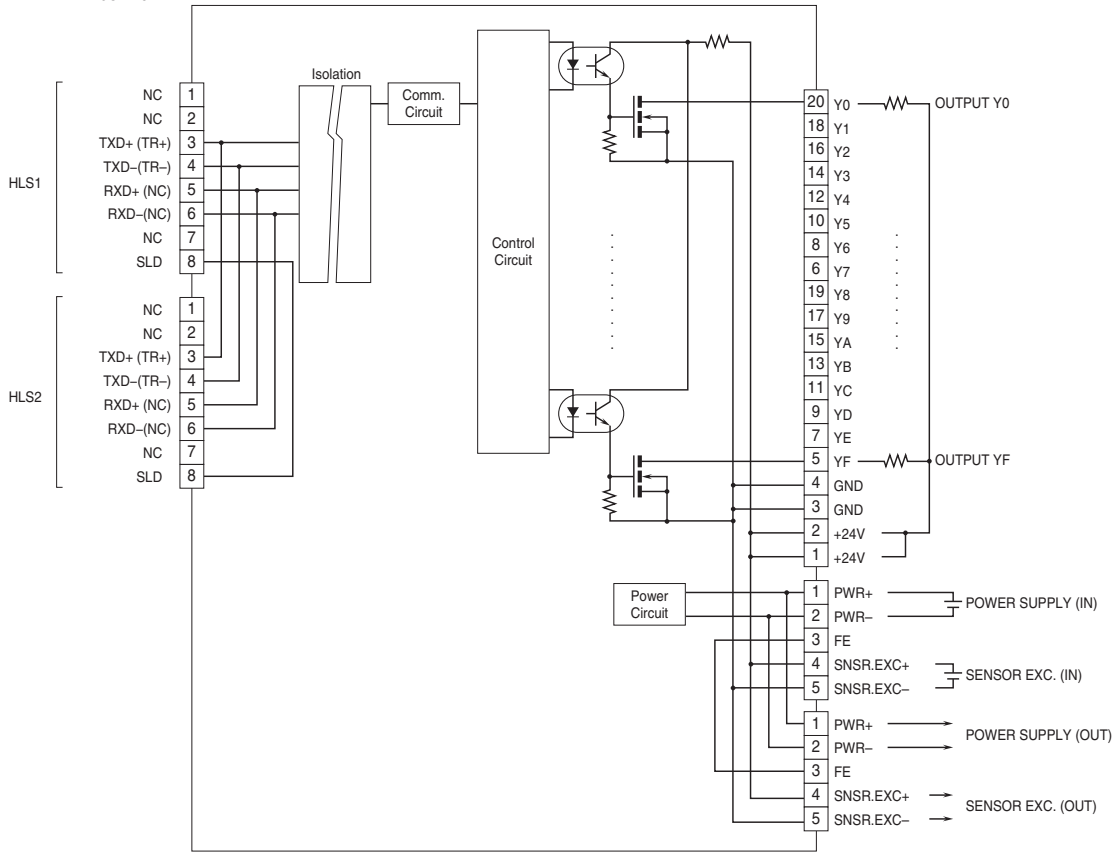

## PNP TRANSISTOR OUTPUT MODULE, 16 points

(MIL connector)

### MODEL:

**R7F4DH-2-DC16B**

**R7F4DH-3-DC16B**

### SPECIFICATIONS

**Common:** Positive common (PNP) per 16 points

**Number of I/O:** Output, 16 points

**Maximum outputs applicable at once:** No limit (at 24 V DC)

**I/O status indicator:** LED turns on with closed contact.

**Isolation:** Output or sensor excitation to HLS to power input to FE

**Data allocation:** 1

**Rated load voltage:** 24 V AC  $\pm 10\%$  (ripple 5 %p-p max.)

**Rated output current:** 0.1 A per point, 1.6 A per common

**Residual voltage:**  $\leq 1.2$  V

**Leakage current:**  $\leq 0.1$  mA

**ON delay:**  $\leq 0.5$  msec.

**OFF delay:**  $\leq 0.5$  msec.

**Overload current protection function:** Limits the current value when overcurrent is detected

**Overheat Protection Function:**

Turns OFF the output when overheat is detected

### TERMINAL ASSIGNMENTS

#### ■ Output Connection

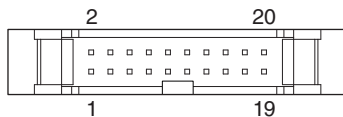

#### 1. Terminal block code 2

PIN No	ID	FUNCTION	PIN No	ID	FUNCTION
1	Y0	Output 0	11	YA	Output 10
2	Y1	Output 1	12	YB	Output 11
3	Y2	Output 2	13	YC	Output 12
4	Y3	Output 3	14	YD	Output 13
5	Y4	Output 4	15	YE	Output 14
6	Y5	Output 5	16	YF	Output 15
7	Y6	Output 6	17	GND	0V
8	Y7	Output 7	18	GND	0V
9	Y8	Output 8	19	+24V	24VDC
10	Y9	Output 9	20	+24V	24VDC

#### 2. Terminal block code 3

PIN No	ID	FUNCTION	PIN No	ID	FUNCTION
1	+24V	24VDC	11	YC	Output 12
2	+24V	24VDC	12	Y4	Output 4
3	GND	0V	13	YB	Output 11
4	GND	0V	14	Y3	Output 3
5	YF	Output 15	15	YA	Output 10
6	Y7	Output 7	16	Y2	Output 2
7	YE	Output 14	17	Y9	Output 9
8	Y6	Output 6	18	Y1	Output 1
9	YD	Output 13	19	Y8	Output 8
10	Y5	Output 5	20	Y0	Output 0

## SCHEMATIC CIRCUITRY

### ■ TERMINAL CODE 2

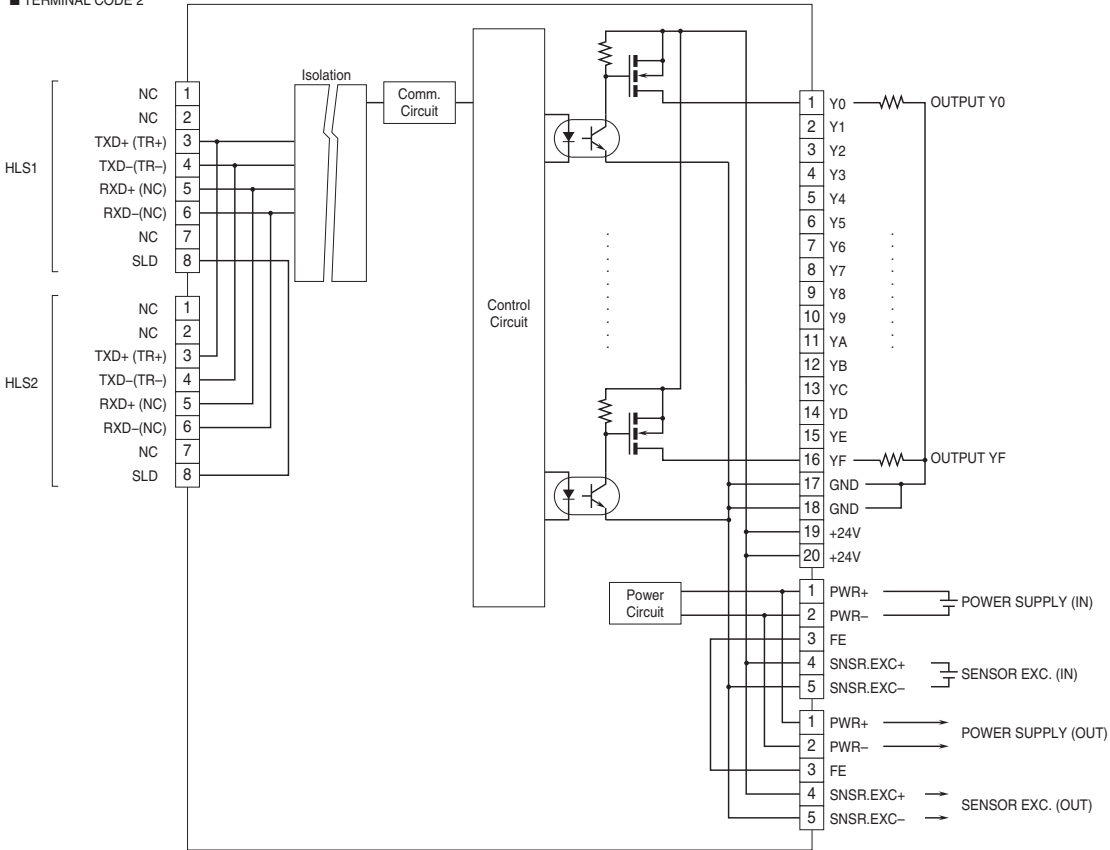

### ■ TERMINAL CODE 3

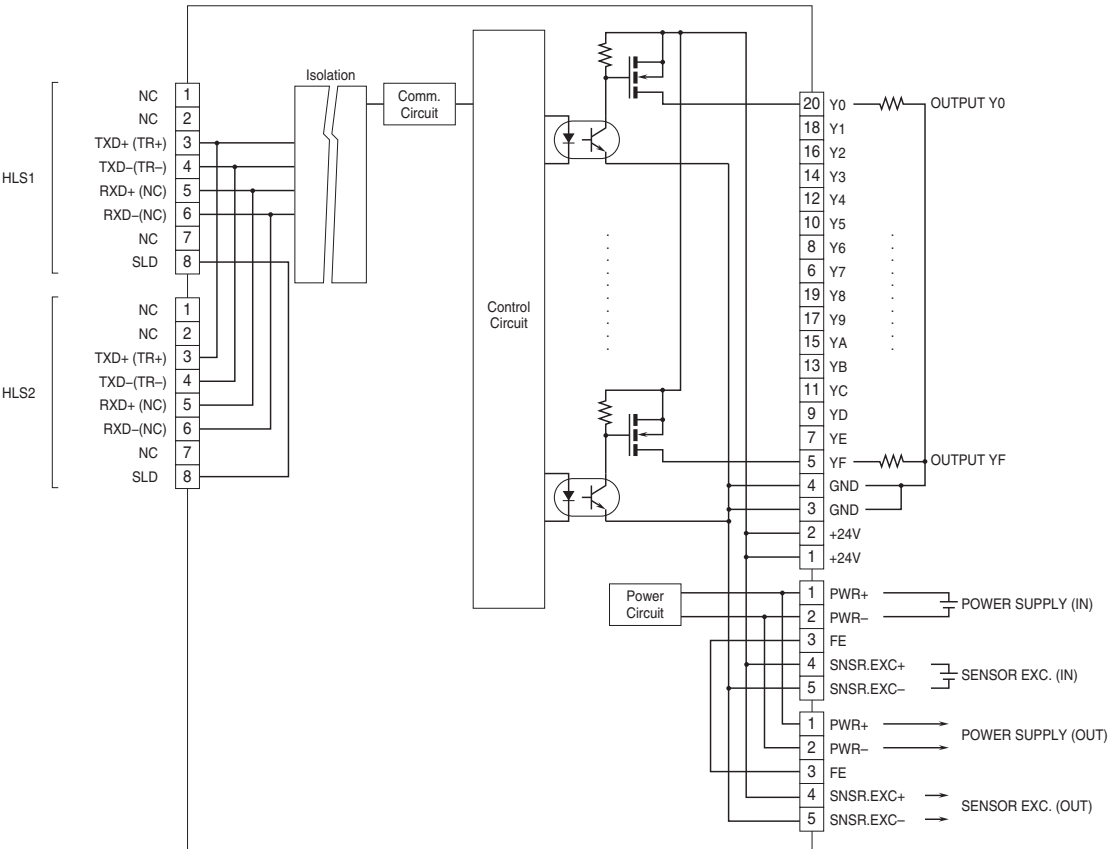

## PNP DISCRETE INPUT &

### NPN TRANSISTOR OUTPUT MODULE, 8 points each

(MIL connector)

### MODEL:

**R7F4DH-2-DAC16A**

**R7F4DH-3-DAC16A**

## SPECIFICATIONS

### COMMON SPECIFICATIONS

**Common:** Negative common per 16 points

**Input rating/load voltage:** 24 V DC  $\pm 10\%$ , ripple 5 %p-p max.

**Number of I/O:** Input, 8 points; Output, 8 points

**Maximum I/O applicable at once:** No limit (at 24 V DC)

**I/O status indicator:** LED turns on with closed contact.

**Isolation:** I/O or sensor excitation to HLS to power input to FE

**Data allocation:** 1

### INPUT

**ON voltage / current:**  $\geq 15$  V DC (I/O's X0 through X7 to 0 V) /  $\geq 3.5$  mA

**OFF voltage / current:**  $\leq 5$  V DC (I/O's X0 through X7 to 0 V) /  $\leq 1$  mA

**Input current:**  $\leq 5.5$  mA per point at 24 V DC

**Input resistance:** Approx. 4.4 k $\Omega$

**ON delay:**  $\leq 0.5$  msec.

**OFF delay:**  $\leq 0.5$  msec.

### OUTPUT

**Rated output current:** 0.1 A per point, 0.8 A per common

**Residual voltage:**  $\leq 1.2$  V

**Leakage current:**  $\leq 0.1$  mA

**ON delay:**  $\leq 0.5$  msec.

**OFF delay:**  $\leq 0.5$  msec.

**Overload current protection function:** Limits the current value when overcurrent is detected

**Overheat Protection Function:**

Turns OFF the output when overheat is detected

## TERMINAL ASSIGNMENTS

### I/O Connection

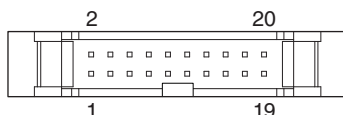

### 1. Terminal block code 2

PIN No	ID	FUNCTION	PIN No	ID	FUNCTION
1	X0	Input 0	11	Y2	Output 2
2	X1	Input 1	12	Y3	Output 3
3	X2	Input 2	13	Y4	Output 4
4	X3	Input 3	14	Y5	Output 5
5	X4	Input 4	15	Y6	Output 6
6	X5	Input 5	16	Y7	Output 7
7	X6	Input 6	17	GND	0V
8	X7	Input 7	18	GND	0V
9	Y0	Output 0	19	+24V	24VDC
10	Y1	Output 1	20	+24V	24VDC

### 2. Terminal block code 3

PIN No	ID	FUNCTION	PIN No	ID	FUNCTION
1	+24V	24VDC	11	Y4	Output 4
2	+24V	24VDC	12	X4	Input 4
3	GND	0V	13	Y3	Output 3
4	GND	0V	14	X3	Input 3
5	Y7	Output 7	15	Y2	Output 2
6	X7	Input 7	16	X2	Input 2
7	Y6	Output 6	17	Y1	Output 1
8	X6	Input 6	18	X1	Input 1
9	Y5	Output 5	19	Y0	Output 0
10	X5	Input 5	20	X0	Input 0

## SCHEMATIC CIRCUITRY

■ TERMINAL CODE 2

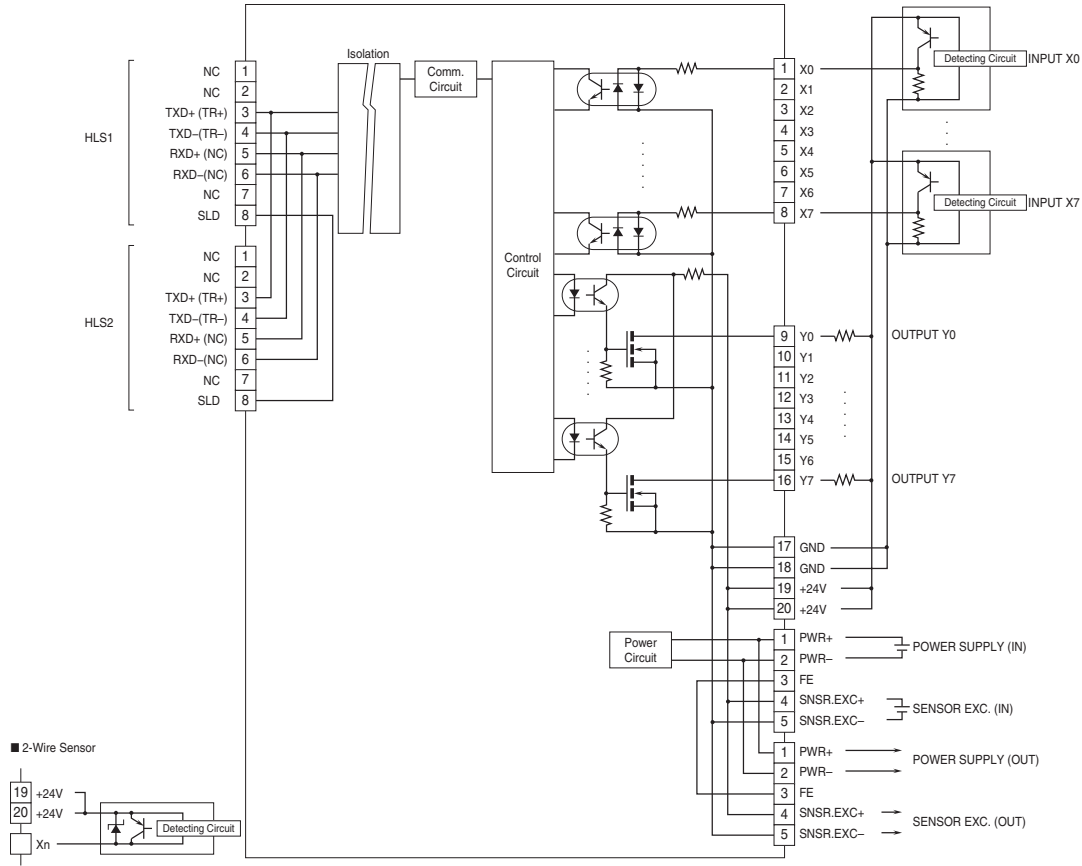

■ TERMINAL CODE 3

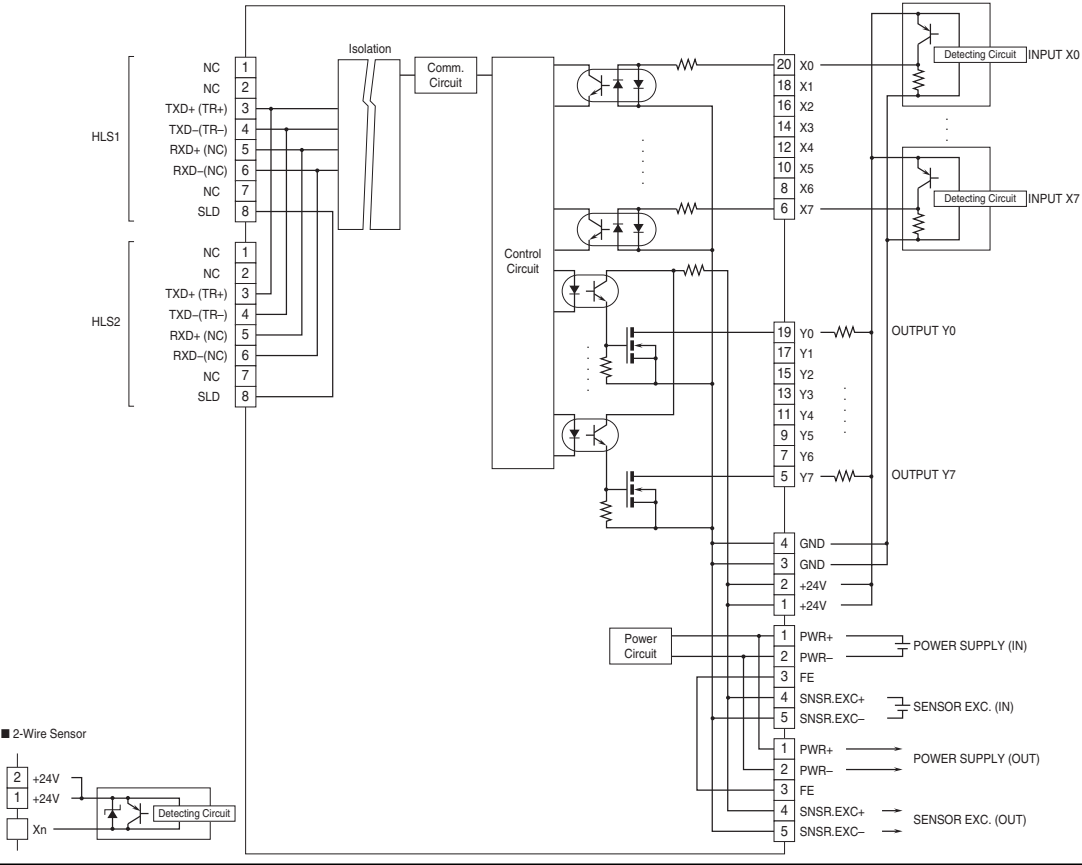

## NPN DISCRETE INPUT &

### PNP TRANSISTOR OUTPUT MODULE, 8 points each

(MIL connector)

#### MODEL:

**R7F4DH-2-DAC16B**

**R7F4DH-3-DAC16B**

## SPECIFICATIONS

### COMMON SPECIFICATIONS

**Common:** Positive common per 16 points

**Input rating/load voltage:** 24 V DC  $\pm 10\%$ , ripple 5 %p-p max.

**Number of I/O:** Input, 8 points; Output, 8 points

**Maximum I/O applicable at once:** No limit (at 24 V DC)

**I/O status indicator:** LED turns on with closed contact.

**Isolation:** I/O or sensor excitation to HLS to power input to FE

**Data allocation:** 1

### INPUT

**ON voltage / current:**  $\geq 15$  V DC (I/O's X0 through X7 to +24 V) /  $\geq 3.5$  mA

**OFF voltage / current:**  $\leq 5$  V DC (I/O's X0 through X7 to +24 V) /  $\leq 1$  mA

**Input current:**  $\leq 5.5$  mA per point at 24 V DC

**Input resistance:** Approx. 4.4 k $\Omega$

**ON delay:**  $\leq 0.5$  msec.

**OFF delay:**  $\leq 0.5$  msec.

### OUTPUT

**Rated output current:** 0.1 A per point, 0.8 A per common

**Residual voltage:**  $\leq 1.2$  V

**Leakage current:**  $\leq 0.1$  mA

**ON delay:**  $\leq 0.5$  msec.

**OFF delay:**  $\leq 0.5$  msec.

**Overload current protection function:** Limits the current value when overcurrent is detected

**Overheat Protection Function:**

Turns OFF the output when overheat is detected

## TERMINAL ASSIGNMENTS

### I/O Connection

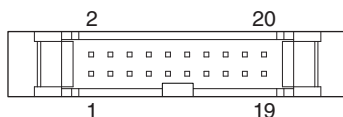

### 1. Terminal block code 2

PIN No	ID	FUNCTION	PIN No	ID	FUNCTION
1	X0	Input 0	11	Y2	Output 2
2	X1	Input 1	12	Y3	Output 3
3	X2	Input 2	13	Y4	Output 4
4	X3	Input 3	14	Y5	Output 5
5	X4	Input 4	15	Y6	Output 6
6	X5	Input 5	16	Y7	Output 7
7	X6	Input 6	17	GND	0V
8	X7	Input 7	18	GND	0V
9	Y0	Output 0	19	+24V	24VDC
10	Y1	Output 1	20	+24V	24VDC

### 2. Terminal block code 3

PIN No	ID	FUNCTION	PIN No	ID	FUNCTION
1	+24V	24VDC	11	Y4	Output 4
2	+24V	24VDC	12	X4	Input 4
3	GND	0V	13	Y3	Output 3
4	GND	0V	14	X3	Input 3
5	Y7	Output 7	15	Y2	Output 2
6	X7	Input 7	16	X2	Input 2
7	Y6	Output 6	17	Y1	Output 1
8	X6	Input 6	18	X1	Input 1
9	Y5	Output 5	19	Y0	Output 0
10	X5	Input 5	20	X0	Input 0

**SCHEMATIC CIRCUITRY**

■ TERMINAL CODE 2

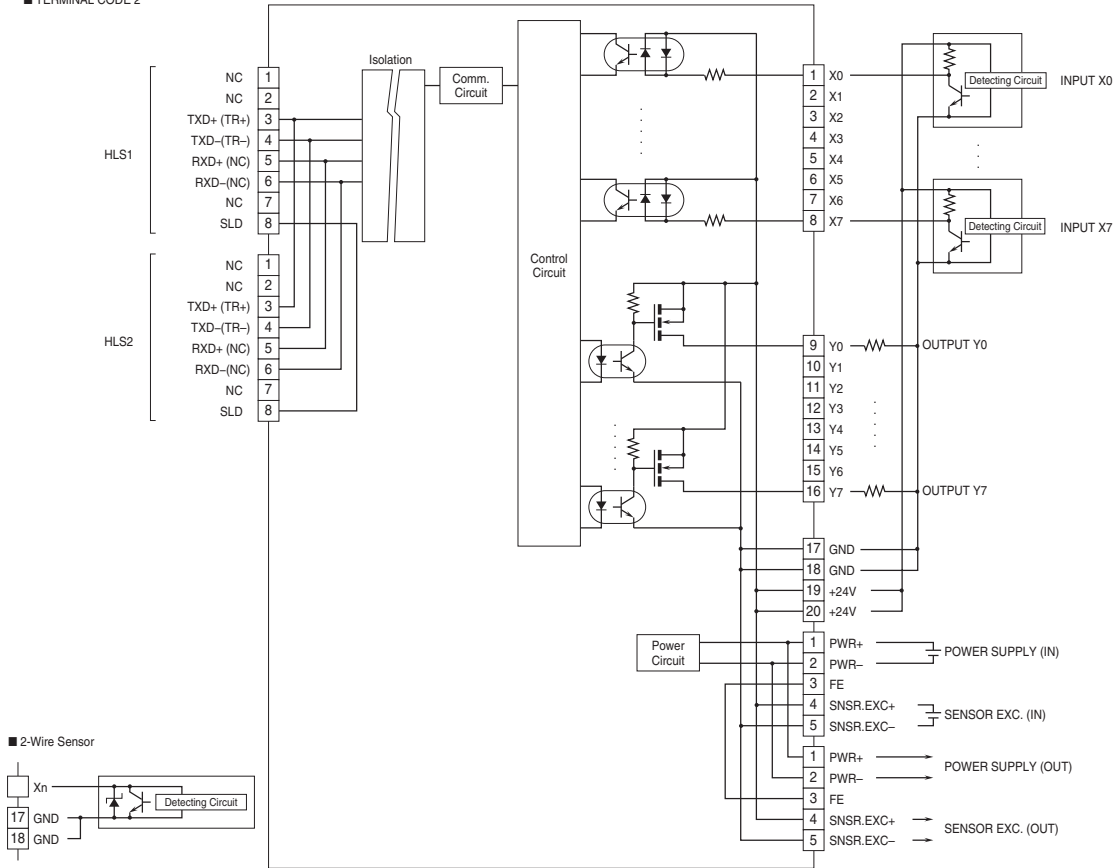

■ TERMINAL CODE 3

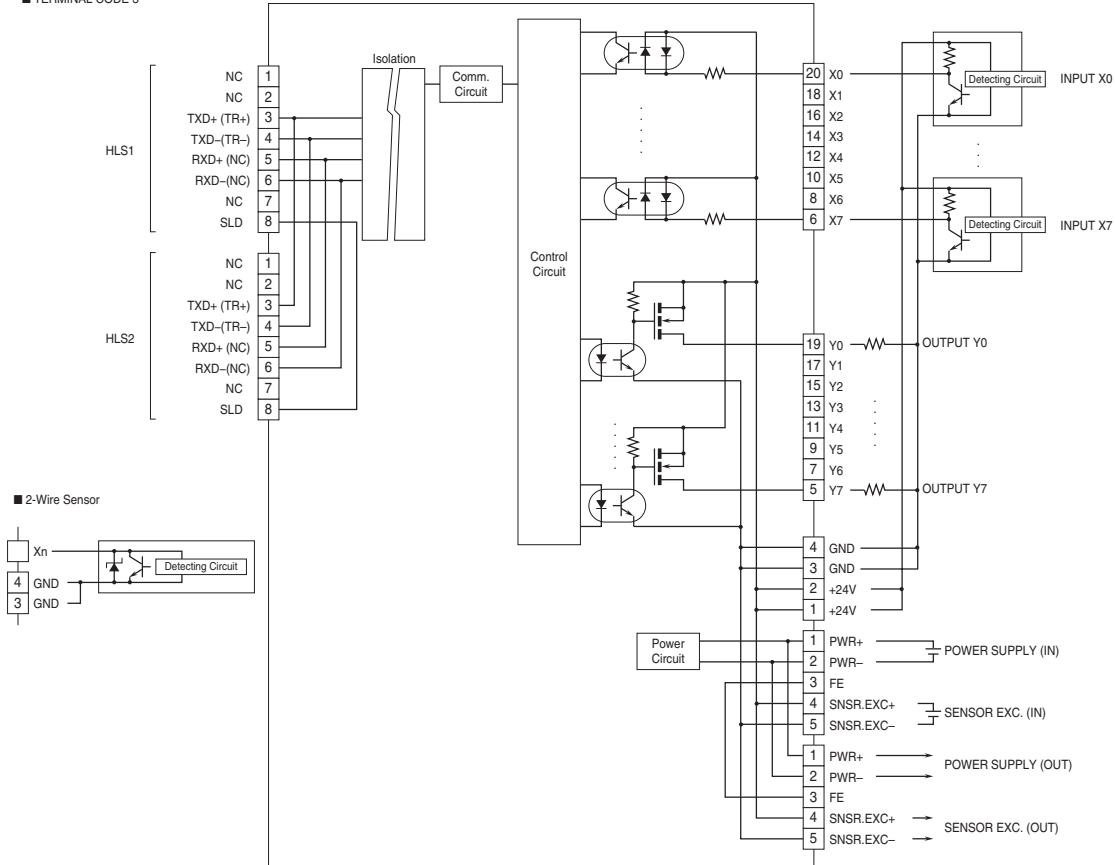

## NPN DISCRETE INPUT &

### NPN TRANSISTOR OUTPUT MODULE, 8 points each

(MIL connector)

#### MODEL:

**R7F4DH-2-DAC16C**

**R7F4DH-3-DAC16C**

## SPECIFICATIONS

### COMMON SPECIFICATIONS

**Input common:** Positive common per 8 points

**Output common:** Negative common per 8 points

**Input rating/load voltage:** 24 V DC  $\pm 10\%$ , ripple 5 %p-p max.

**Number of I/O:** Input, 8 points; Output, 8 points

**Maximum I/O applicable at once:** No limit (at 24 V DC)

**I/O status indicator:** LED turns on with closed contact.

**Isolation:** I/O or sensor excitation to HLS to power input to FE

**Data allocation:** 1

### INPUT

**ON voltage / current:**  $\geq 15$  V DC (I/O's X0 through X7 to +24 V) /  $\geq 3.5$  mA

**OFF voltage / current:**  $\leq 5$  V DC (I/O's X0 through X7 to +24 V) /  $\leq 1$  mA

**Input current:**  $\leq 5.5$  mA per point at 24 V DC

**Input resistance:** Approx. 4.4 k $\Omega$

**ON delay:**  $\leq 0.5$  msec.

**OFF delay:**  $\leq 0.5$  msec.

### OUTPUT

**Rated output current:** 0.1 A per point, 0.8 A per common

**Residual voltage:**  $\leq 1.2$  V

**Leakage current:**  $\leq 0.1$  mA

**ON delay:**  $\leq 0.5$  msec.

**OFF delay:**  $\leq 0.5$  msec.

**Overload current protection function:** Limits the current value when overcurrent is detected

**Overheat Protection Function:**

Turns OFF the output when overheat is detected

## TERMINAL ASSIGNMENTS

### I/O Connection

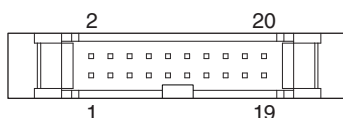

### 1. Terminal block code 2

PIN No	ID	FUNCTION	PIN No	ID	FUNCTION
1	X0	Input 0	11	Y2	Output 2
2	X1	Input 1	12	Y3	Output 3
3	X2	Input 2	13	Y4	Output 4
4	X3	Input 3	14	Y5	Output 5
5	X4	Input 4	15	Y6	Output 6
6	X5	Input 5	16	Y7	Output 7
7	X6	Input 6	17	GND	0V
8	X7	Input 7	18	GND	0V
9	Y0	Output 0	19	+24V	24VDC
10	Y1	Output 1	20	+24V	24VDC

### 2. Terminal block code 3

PIN No	ID	FUNCTION	PIN No	ID	FUNCTION
1	+24V	24VDC	11	Y4	Output 4
2	+24V	24VDC	12	X4	Input 4
3	GND	0V	13	Y3	Output 3
4	GND	0V	14	X3	Input 3
5	Y7	Output 7	15	Y2	Output 2
6	X7	Input 7	16	X2	Input 2
7	Y6	Output 6	17	Y1	Output 1
8	X6	Input 6	18	X1	Input 1
9	Y5	Output 5	19	Y0	Output 0
10	X5	Input 5	20	X0	Input 0

**SCHEMATIC CIRCUITRY**

■ TERMINAL CODE 2

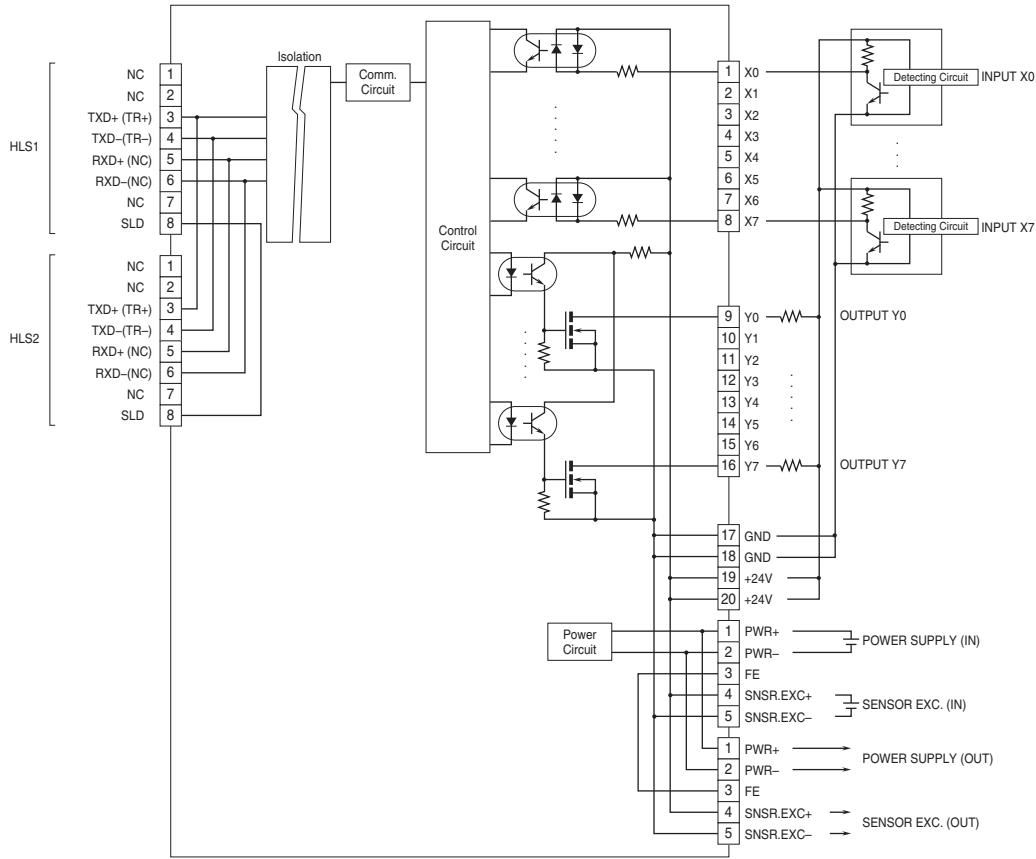

■ TERMINAL CODE 3

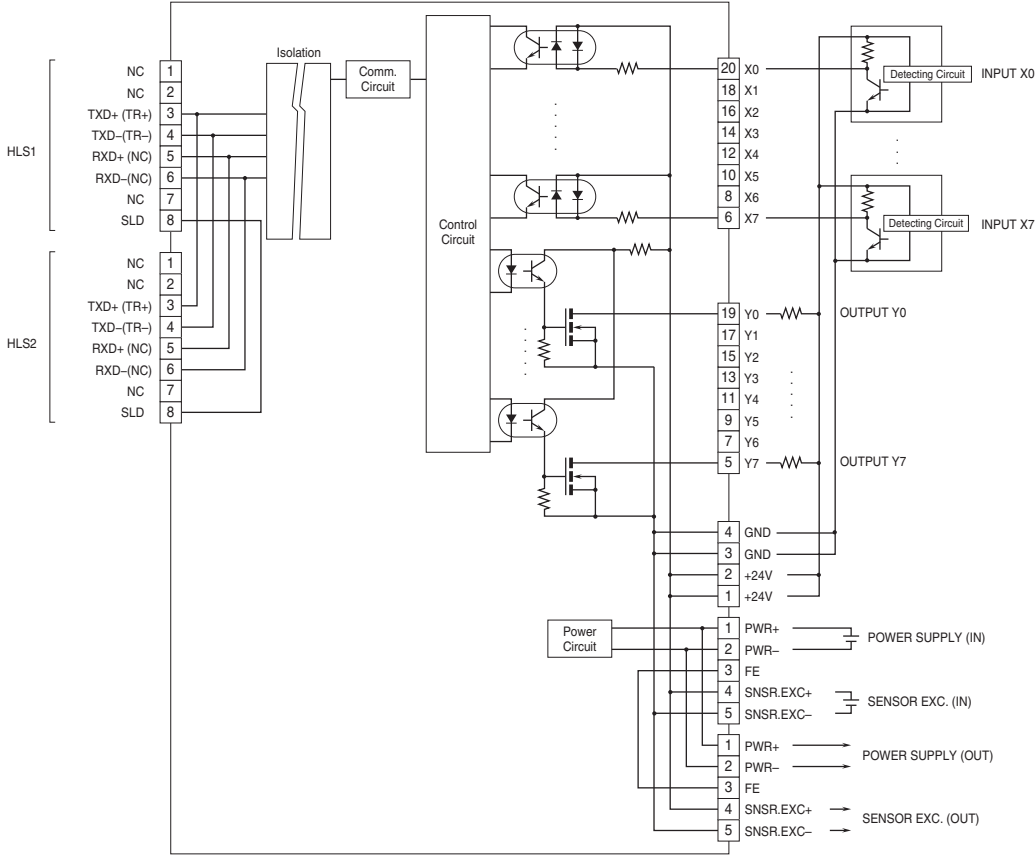

## PNP DISCRETE INPUT &

### PNP TRANSISTOR OUTPUT MODULE, 8 points each

(MIL connector)

#### MODEL:

**R7F4DH-2-DAC16D**

**R7F4DH-3-DAC16D**

## SPECIFICATIONS

### COMMON SPECIFICATIONS

**Input common:** Negative common per 8 points

**Output common:** Positive common per 8 points

**Input rating/load voltage:** 24 V DC  $\pm 10\%$ , ripple 5 %p-p max.

**Number of I/O:** Input, 8 points; Output, 8 points

**Maximum I/O applicable at once:** No limit (at 24 V DC)

**I/O status indicator:** LED turns on with closed contact.

**Isolation:** I/O or sensor excitation to HLS to power input to FE

**Data allocation:** 1

### INPUT

**ON voltage / current:**  $\geq 15$  V DC (I/O's X0 through X7 to 0 V) /  $\geq 3.5$  mA

**OFF voltage / current:**  $\leq 5$  V DC (I/O's X0 through X7 to 0 V) /  $\leq 1$  mA

**Input current:**  $\leq 5.5$  mA per point at 24 V DC

**Input resistance:** Approx. 4.4 k $\Omega$

**ON delay:**  $\leq 0.5$  msec.

**OFF delay:**  $\leq 0.5$  msec.

### OUTPUT

**Rated output current:** 0.1 A per point, 0.8 A per common

**Residual voltage:**  $\leq 1.2$  V

**Leakage current:**  $\leq 0.1$  mA

**ON delay:**  $\leq 0.5$  msec.

**OFF delay:**  $\leq 0.5$  msec.

**Overload current protection function:** Limits the current value when overcurrent is detected

**Overheat Protection Function:**

Turns OFF the output when overheat is detected

## TERMINAL ASSIGNMENTS

### I/O Connection

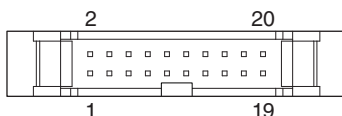

### 1. Terminal block code 2

PIN No	ID	FUNCTION	PIN No	ID	FUNCTION
1	X0	Input 0	11	Y2	Output 2
2	X1	Input 1	12	Y3	Output 3
3	X2	Input 2	13	Y4	Output 4
4	X3	Input 3	14	Y5	Output 5
5	X4	Input 4	15	Y6	Output 6
6	X5	Input 5	16	Y7	Output 7
7	X6	Input 6	17	GND	0V
8	X7	Input 7	18	GND	0V
9	Y0	Output 0	19	+24V	24VDC
10	Y1	Output 1	20	+24V	24VDC

### 2. Terminal block code 3

PIN No	ID	FUNCTION	PIN No	ID	FUNCTION
1	+24V	24VDC	11	Y4	Output 4
2	+24V	24VDC	12	X4	Input 4
3	GND	0V	13	Y3	Output 3
4	GND	0V	14	X3	Input 3
5	Y7	Output 7	15	Y2	Output 2
6	X7	Input 7	16	X2	Input 2
7	Y6	Output 6	17	Y1	Output 1
8	X6	Input 6	18	X1	Input 1
9	Y5	Output 5	19	Y0	Output 0
10	X5	Input 5	20	X0	Input 0

## SCHEMATIC CIRCUITRY

### ■ TERMINAL CODE 2

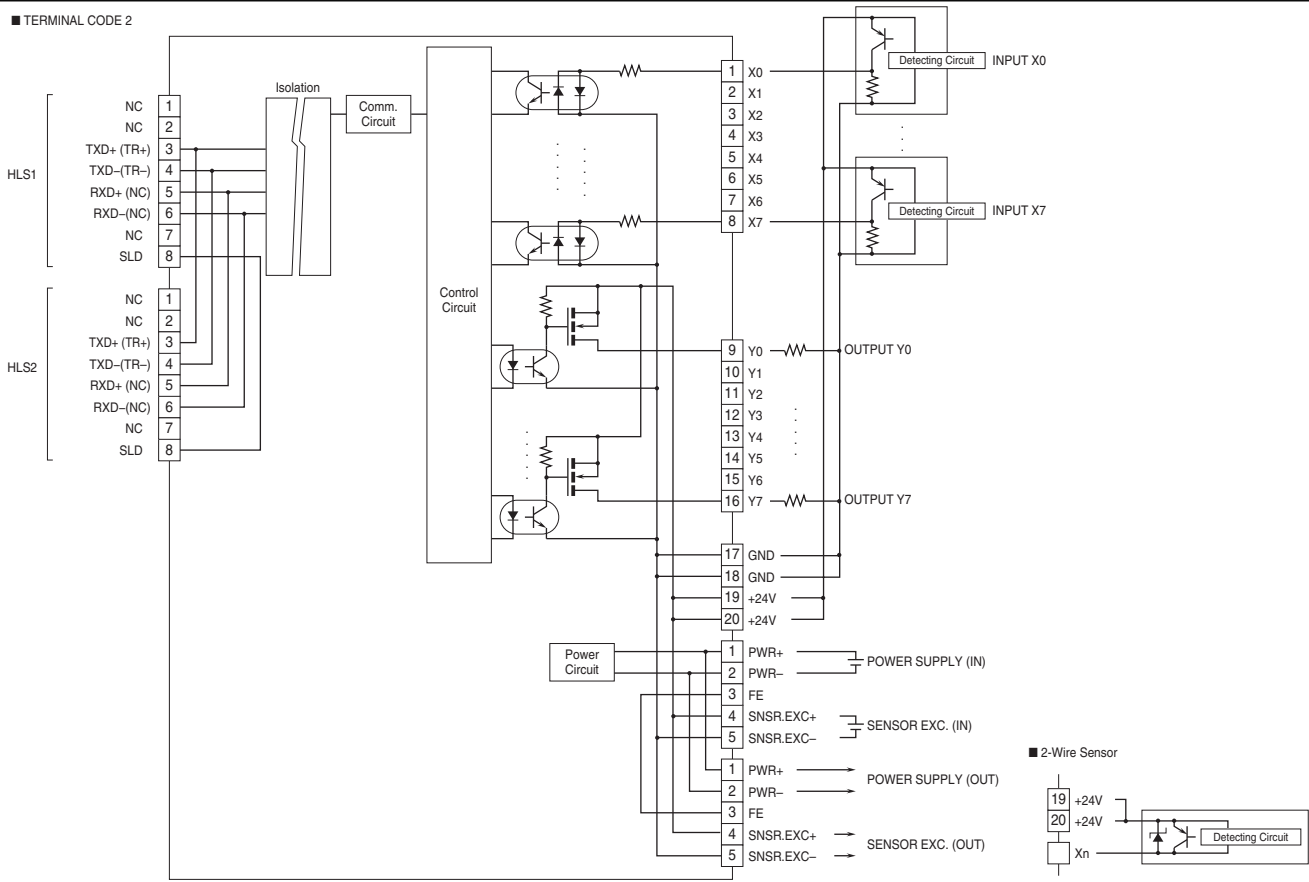

### ■ TERMINAL CODE 3

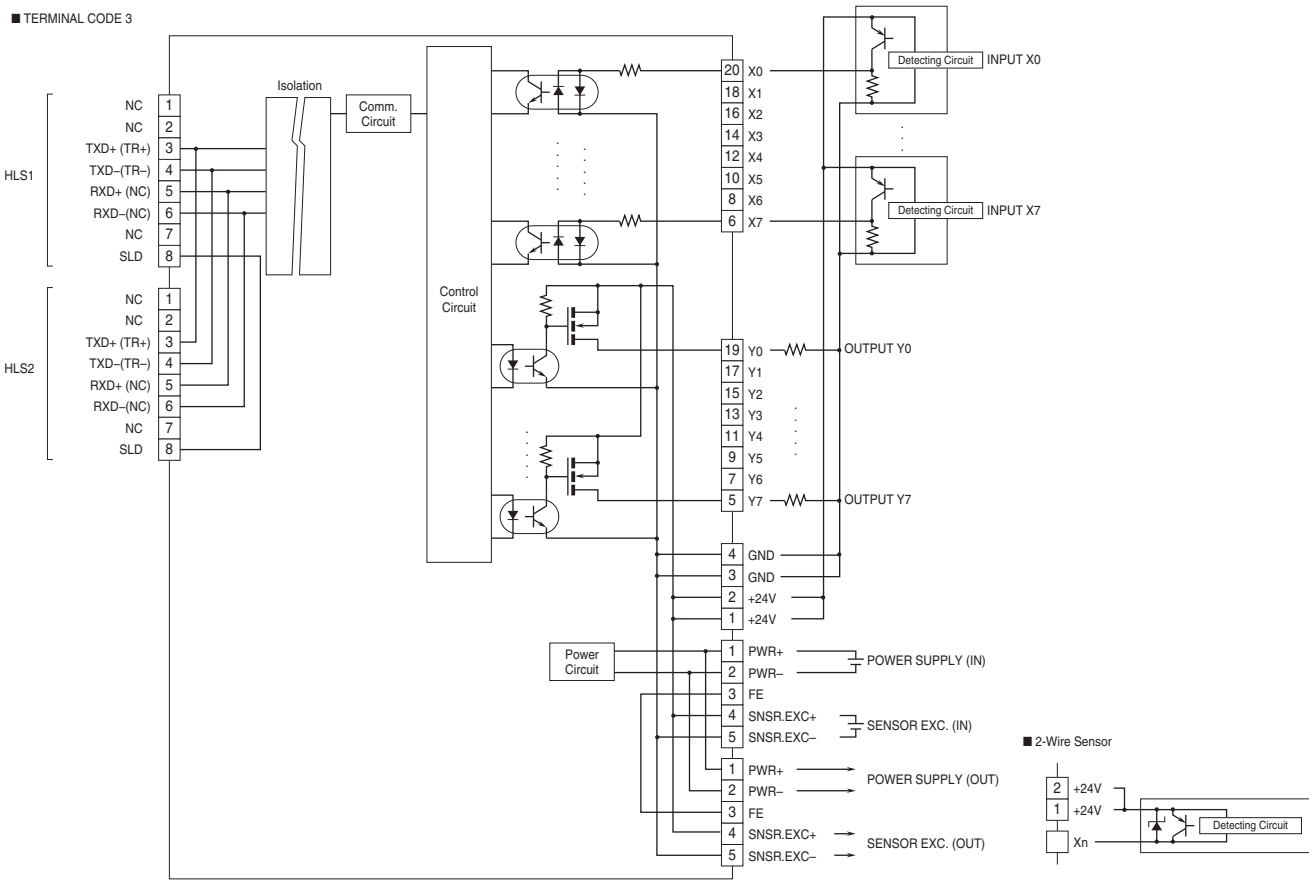

## NPN DISCRETE INPUT MODULE, 16 points

(Tension clamp terminal block)

### MODEL: R7F4DH-4-DA16A

#### SPECIFICATIONS

**Common:** Positive common (NPN) per 16 points

**Number of I/O:** Input, 16 points

**Maximum inputs applicable at once:** No limit (at 24 V DC)

**I/O status indicator:** LED turns on with closed contact.

**Isolation:** Input or sensor excitation to HLS to power input to FE

**Data allocation:** 1

**Rated input voltage:** 24 V DC  $\pm 10\%$ ; ripple 5 %p-p max.

**ON voltage / current:**  $\geq 15$  V DC (input - +24V) /  $\geq 3.5$  mA

**OFF voltage / current:**  $\leq 5$  V DC (input - +24V) /  $\leq 1$  mA

**Input current:**  $\leq 5.5$  mA per point at 24 V DC

**Input resistance:** Approx. 4.4 k $\Omega$

**ON delay:**  $\leq 0.5$  msec.

**OFF delay:**  $\leq 0.5$  msec.

#### TERMINAL ASSIGNMENTS

##### ■ Input Connection

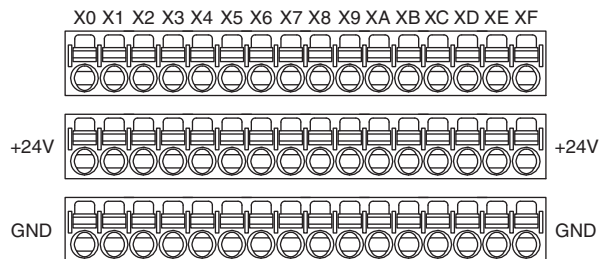

PIN No	ID	FUNCTION	PIN No	ID	FUNCTION
X0	1	X0	X8	1	X8
	2	+24V		2	+24V
	3	GND		3	GND
X1	1	X1	X9	1	X9
	2	+24V		2	+24V
	3	GND		3	GND
X2	1	X2	XA	1	XA
	2	+24V		2	+24V
	3	GND		3	GND
X3	1	X3	XB	1	XB
	2	+24V		2	+24V
	3	GND		3	GND
X4	1	X4	XC	1	XC
	2	+24V		2	+24V
	3	GND		3	GND
X5	1	X5	XD	1	XD
	2	+24V		2	+24V
	3	GND		3	GND
X6	1	X6	XE	1	XE
	2	+24V		2	+24V
	3	GND		3	GND
X7	1	X7	XF	1	XF
	2	+24V		2	+24V
	3	GND		3	GND

**SCHEMATIC CIRCUITRY**

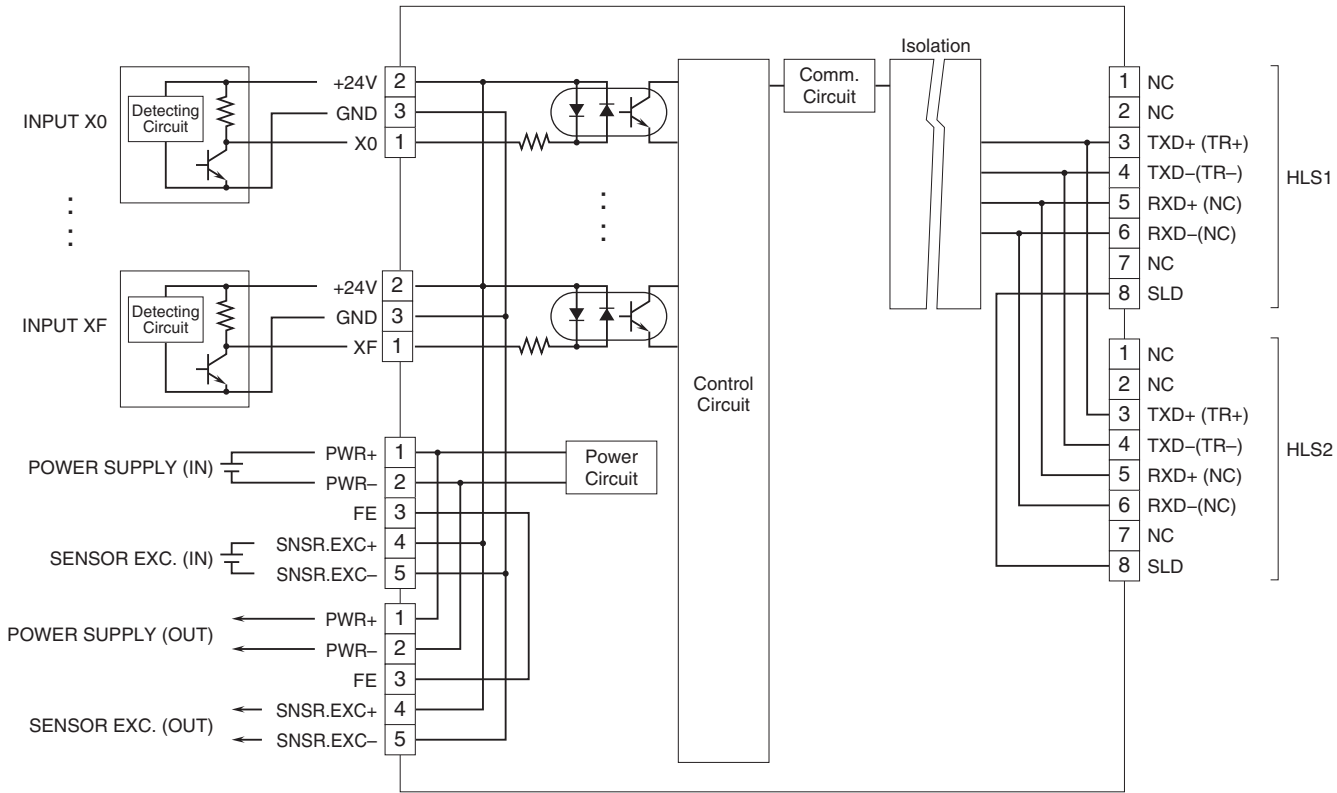

■ 2-Wire Sensor

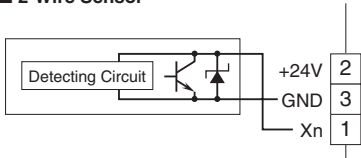

## PNP DISCRETE INPUT MODULE, 16 points

(Tension clamp terminal block)

### MODEL: R7F4DH-4-DA16B

#### SPECIFICATIONS

**Common:** Negative common (PNP) per 16 points

**Number of I/O:** Input, 16 points

**Maximum inputs applicable at once:** No limit (at 24 V DC)

**I/O status indicator:** LED turns on with closed contact.

**Isolation:** Input or sensor excitation to HLS to power input to FE

**Data allocation:** 1

**Rated input voltage:** 24 V DC  $\pm 10\%$ ; ripple 5 %p-p max.

**ON voltage / current:**  $\geq 15$  V DC (input - 0V) /  $\geq 3.5$  mA

**OFF voltage / current:**  $\leq 5$  V DC (input - 0V) /  $\leq 1$  mA

**Input current:**  $\leq 5.5$  mA per point at 24 V DC

**Input resistance:** Approx. 4.4 k $\Omega$

**ON delay:**  $\leq 0.5$  msec.

**OFF delay:**  $\leq 0.5$  msec.

#### TERMINAL ASSIGNMENTS

##### Input Connection

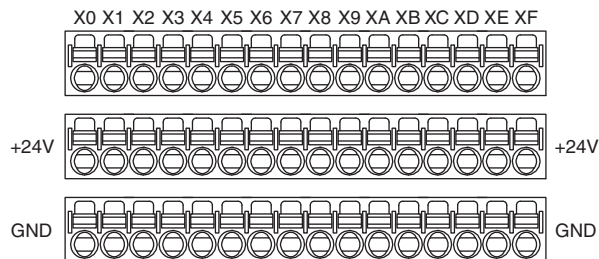

PIN No	ID	FUNCTION	PIN No	ID	FUNCTION
X0	1	X0	X8	1	X8
	2	+24V		2	+24V
	3	GND		3	GND
X1	1	X1	X9	1	X9
	2	+24V		2	+24V
	3	GND		3	GND
X2	1	X2	XA	1	XA
	2	+24V		2	+24V
	3	GND		3	GND
X3	1	X3	XB	1	XB
	2	+24V		2	+24V
	3	GND		3	GND
X4	1	X4	XC	1	XC
	2	+24V		2	+24V
	3	GND		3	GND
X5	1	X5	XD	1	XD
	2	+24V		2	+24V
	3	GND		3	GND
X6	1	X6	XE	1	XE
	2	+24V		2	+24V
	3	GND		3	GND
X7	1	X7	XF	1	XF
	2	+24V		2	+24V
	3	GND		3	GND

**SCHEMATIC CIRCUITRY**

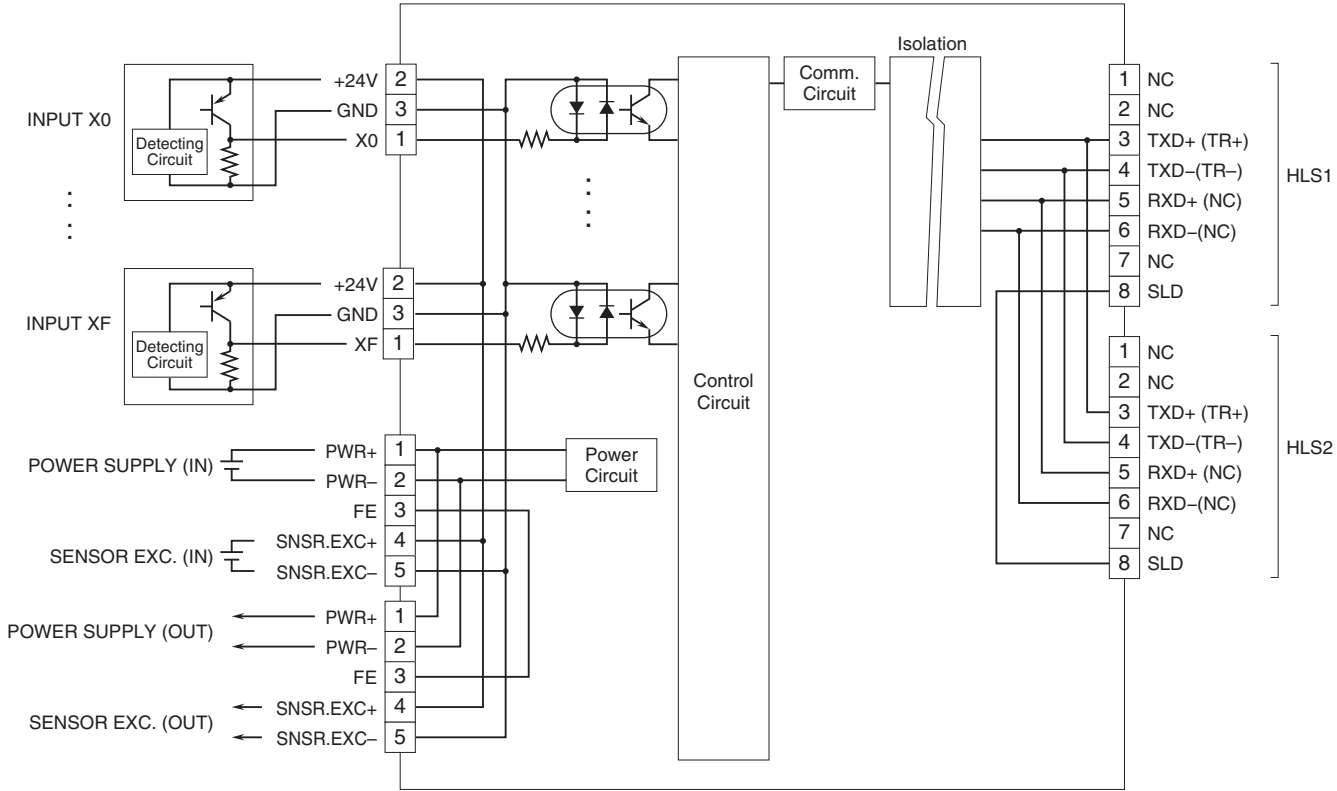

■ 2-Wire Sensor

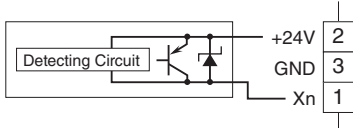

## NPN TRANSISTOR OUTPUT MODULE, 16 points

(Tension clamp terminal block)

### MODEL: R7F4DH-4-DC16A

#### SPECIFICATIONS

**Common:** Negative common (NPN) per 16 points

**Number of I/O:** Output, 16 points

**Maximum outputs applicable at once:** No limit (at 24 V DC)

**I/O status indicator:** LED turns on with closed contact.

**Isolation:** Output or sensor excitation to HLS to power input to FE

**Data allocation:** 1

**Rated load voltage:** 24 V AC  $\pm 10\%$  (ripple 5 %p-p max.)

**Rated output current:** 0.1 A per point, 1.6 A per common

**Residual voltage:**  $\leq 1.2$  V

**Leakage current:**  $\leq 0.1$  mA

**ON delay:**  $\leq 0.5$  msec.

**OFF delay:**  $\leq 0.5$  msec.

**Overload current protection function:** Limits the current value when overcurrent is detected

**Overheat Protection Function:**

Turns OFF the output when overheat is detected

#### TERMINAL ASSIGNMENTS

##### ■ Output Connection

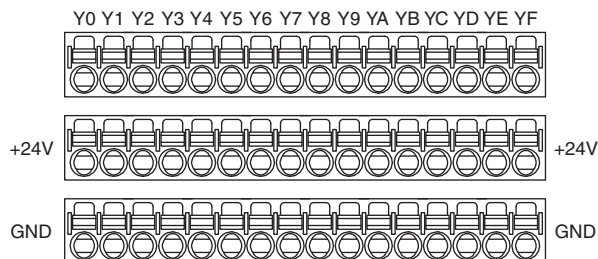

PIN No	ID	FUNCTION	PIN No	ID	FUNCTION
Y0	1	Y0	Y8	1	Y8
	2	+24V		2	+24V
	3	GND		3	GND
Y1	1	Y1	Y9	1	Y9
	2	+24V		2	+24V
	3	GND		3	GND
Y2	1	Y2	YA	1	YA
	2	+24V		2	+24V
	3	GND		3	GND
Y3	1	Y3	YB	1	YB
	2	+24V		2	+24V
	3	GND		3	GND
Y4	1	Y4	YC	1	YC
	2	+24V		2	+24V
	3	GND		3	GND
Y5	1	Y5	YD	1	YD
	2	+24V		2	+24V
	3	GND		3	GND
Y6	1	Y6	YE	1	YE
	2	+24V		2	+24V
	3	GND		3	GND
Y7	1	Y7	YF	1	YF
	2	+24V		2	+24V
	3	GND		3	GND

**SCHEMATIC CIRCUITRY**

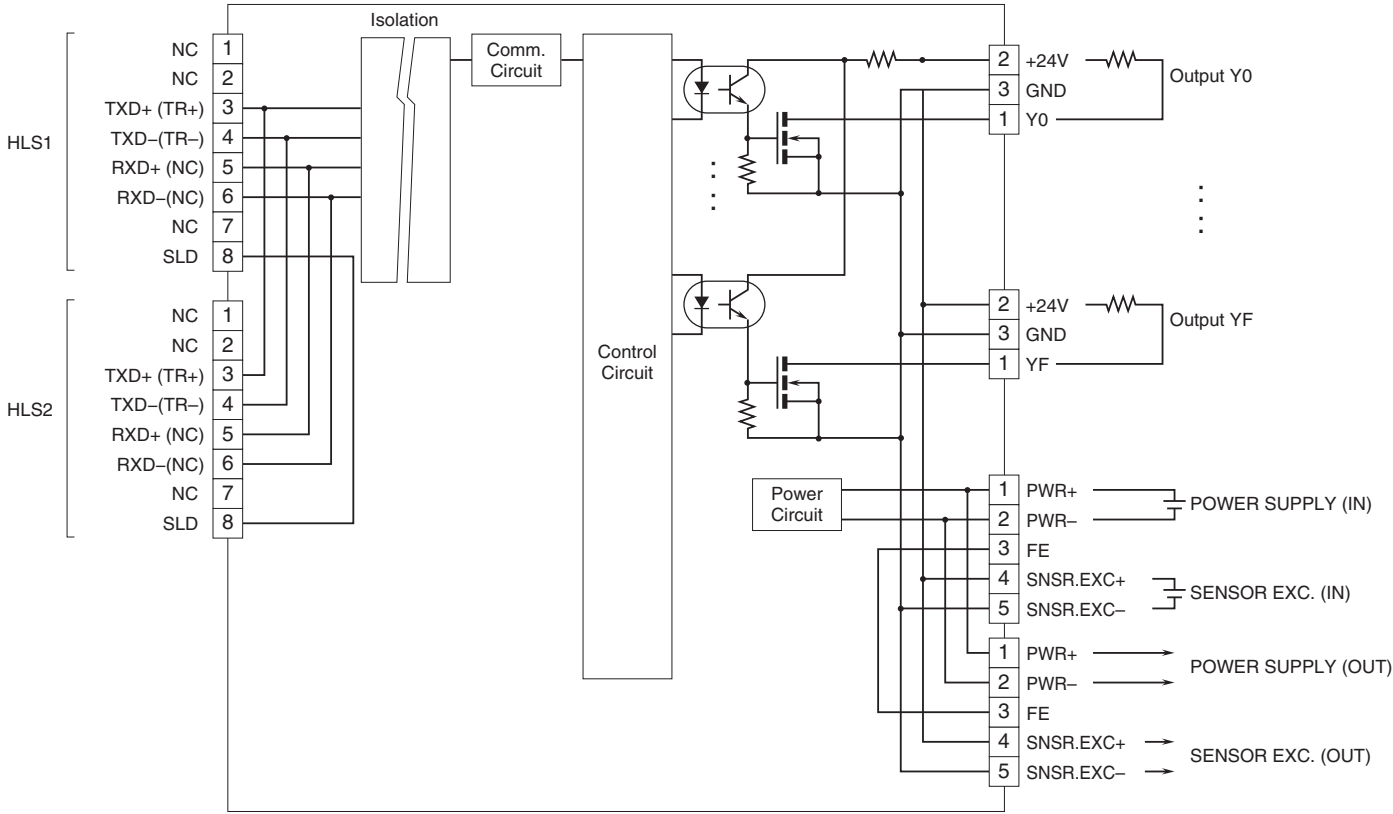

## PNP TRANSISTOR OUTPUT MODULE, 16 points

(Tension clamp terminal block)

### MODEL: R7F4DH-4-DC16B

#### SPECIFICATIONS

**Common:** Positive common (PNP) per 16 points

**Number of I/O:** Output, 16 points

**Maximum outputs applicable at once:** No limit (at 24 V DC)

**I/O status indicator:** LED turns on with closed contact.

**Isolation:** Output or sensor excitation to HLS to power input to FE

**Data allocation:** 1

**Rated load voltage:** 24 V AC  $\pm 10\%$  (ripple 5 %p-p max.)

**Rated output current:** 0.1 A per point, 1.6 A per common

**Residual voltage:**  $\leq 1.2$  V

**Leakage current:**  $\leq 0.1$  mA

**ON delay:**  $\leq 0.5$  msec.

**OFF delay:**  $\leq 0.5$  msec.

**Overload current protection function:** Limits the current value when overcurrent is detected

**Overheat Protection Function:**

Turns OFF the output when overheat is detected

#### TERMINAL ASSIGNMENTS

##### ■ Output Connection

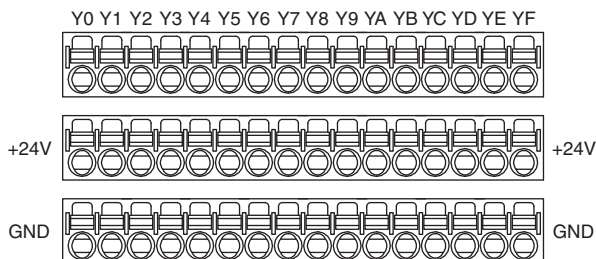

PIN No	ID	FUNCTION	PIN No	ID	FUNCTION
Y0	1	Y0	Y8	1	Y8
	2	+24V		2	+24V
	3	GND		3	GND
Y1	1	Y1	Y9	1	Y9
	2	+24V		2	+24V
	3	GND		3	GND
Y2	1	Y2	YA	1	YA
	2	+24V		2	+24V
	3	GND		3	GND
Y3	1	Y3	YB	1	YB
	2	+24V		2	+24V
	3	GND		3	GND
Y4	1	Y4	YC	1	YC
	2	+24V		2	+24V
	3	GND		3	GND
Y5	1	Y5	YD	1	YD
	2	+24V		2	+24V
	3	GND		3	GND
Y6	1	Y6	YE	1	YE
	2	+24V		2	+24V
	3	GND		3	GND
Y7	1	Y7	YF	1	YF
	2	+24V		2	+24V
	3	GND		3	GND

**SCHEMATIC CIRCUITRY**

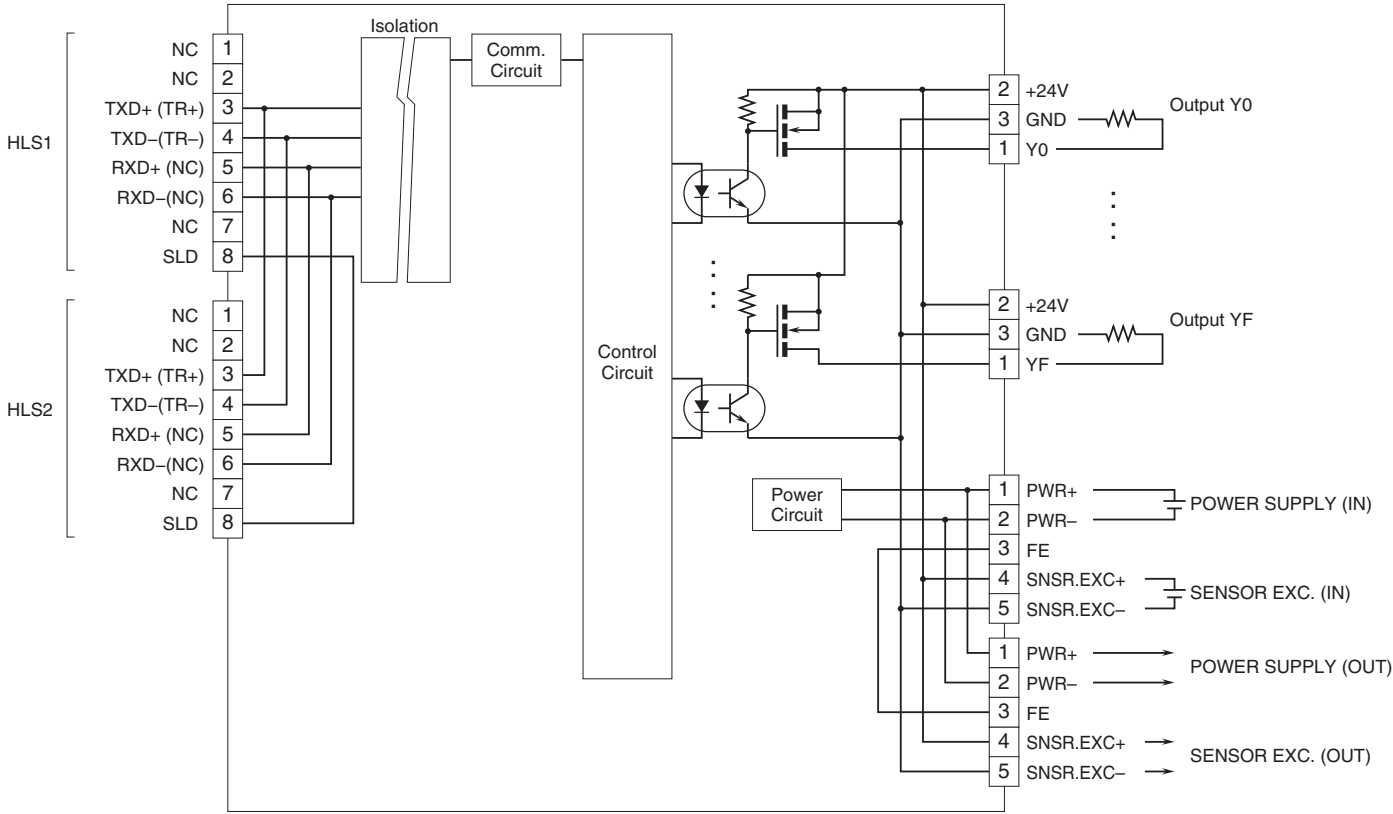

**PNP DISCRETE INPUT & NPN TRANSISTOR OUTPUT MODULE, 8 points each**  
(Tension clamp terminal block)

**MODEL: R7F4DH-4-DAC16A**

**SPECIFICATIONS**

■ COMMON SPECIFICATIONS

**Common:** Negative common per 16 points  
**Input rating/load voltage:** 24 V DC  $\pm 10\%$ , ripple 5 %p-p max.  
**Number of I/O:** Input, 8 points; Output, 8 points  
**Maximum I/O applicable at once:** No limit (at 24 V DC)  
**I/O status indicator:** LED turns on with closed contact.  
**Isolation:** I/O or sensor excitation to HLS to power input to FE

**Data allocation:** 1

■ INPUT

**ON voltage / current:**  $\geq 15$  V DC (I/O's X0 through X7 to 0 V) /  $\geq 3.5$  mA  
**OFF voltage / current:**  $\leq 5$  V DC (I/O's X0 through X7 to 0 V) /  $\leq 1$  mA  
**Input current:**  $\leq 5.5$  mA per point at 24 V DC  
**Input resistance:** Approx. 4.4 k $\Omega$   
**ON delay:**  $\leq 0.5$  msec.  
**OFF delay:**  $\leq 0.5$  msec.

■ OUTPUT

**Rated output current:** 0.1 A per point, 0.8 A per common  
**Residual voltage:**  $\leq 1.2$  V  
**Leakage current:**  $\leq 0.1$  mA  
**ON delay:**  $\leq 0.5$  msec.  
**OFF delay:**  $\leq 0.5$  msec.  
**Overload current protection function:** Limits the current value when overcurrent is detected  
**Overheat Protection Function:** Turns OFF the output when overheat is detected

PIN No	ID	FUNCTION	PIN No	ID	FUNCTION
X0	1	X0	Y0	1	Y0
	2	+24V		2	+24V
	3	GND		3	GND
X1	1	X1	Y1	1	Y1
	2	+24V		2	+24V
	3	GND		3	GND
X2	1	X2	Y2	1	Y2
	2	+24V		2	+24V
	3	GND		3	GND
X3	1	X3	Y3	1	Y3
	2	+24V		2	+24V
	3	GND		3	GND
X4	1	X4	Y4	1	Y4
	2	+24V		2	+24V
	3	GND		3	GND
X5	1	X5	Y5	1	Y5
	2	+24V		2	+24V
	3	GND		3	GND
X6	1	X6	Y6	1	Y6
	2	+24V		2	+24V
	3	GND		3	GND
X7	1	X7	Y7	1	Y7
	2	+24V		2	+24V
	3	GND		3	GND

**TERMINAL ASSIGNMENTS**

■ I/O Connection

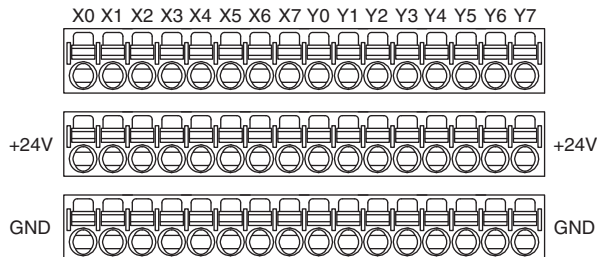

**SCHEMATIC CIRCUITRY**

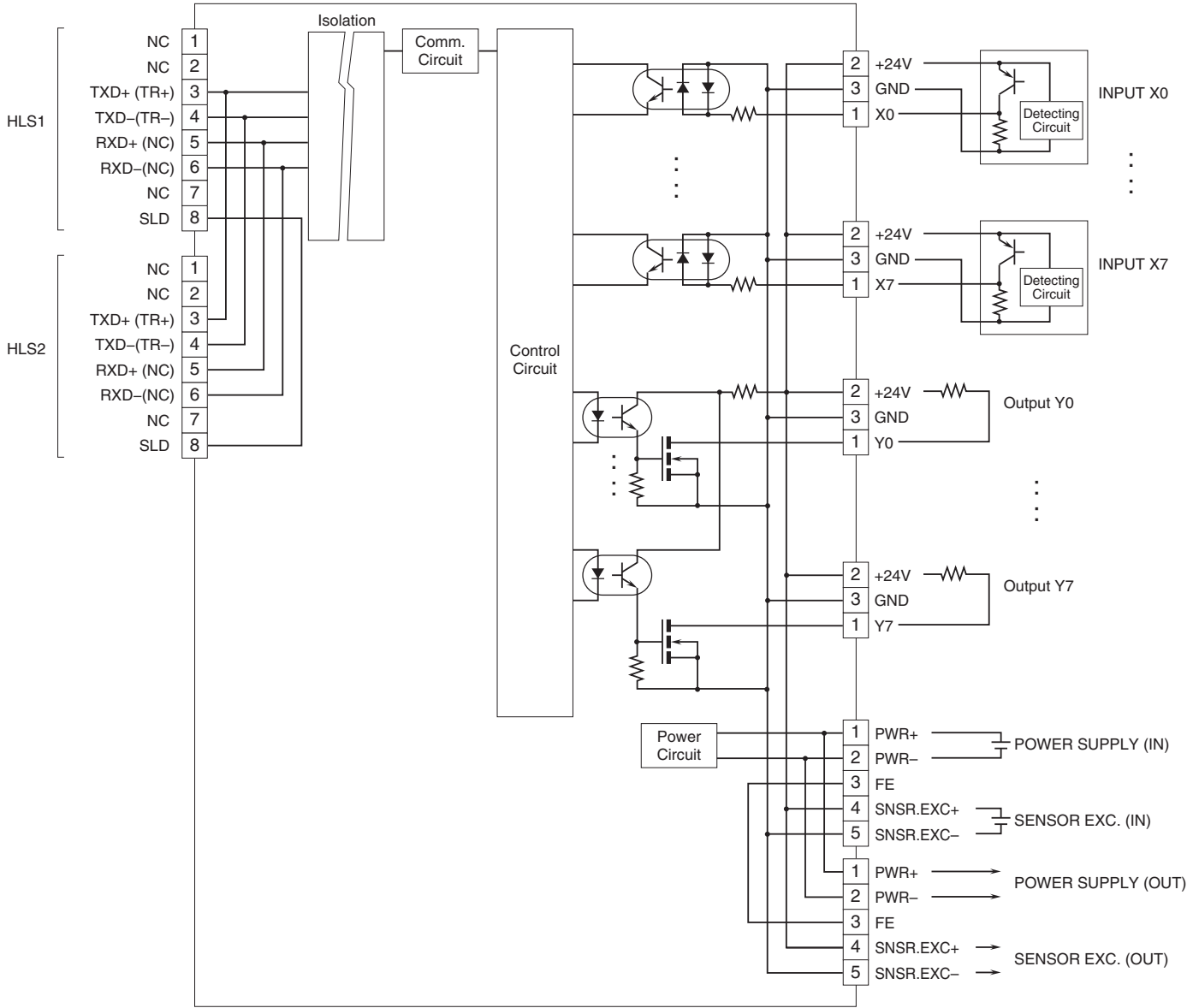

■ 2-Wire Sensor

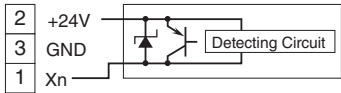

**NPN DISCRETE INPUT & PNP TRANSISTOR OUTPUT MODULE, 8 points each**  
(Tension clamp terminal block)

**MODEL: R7F4DH-4-DAC16B**

**SPECIFICATIONS**

■ COMMON SPECIFICATIONS

**Common:** Positive common per 16 points  
**Input rating/load voltage:** 24 V DC  $\pm 10\%$ , ripple 5 %p-p max.  
**Number of I/O:** Input, 8 points; Output, 8 points  
**Maximum I/O applicable at once:** No limit (at 24 V DC)  
**I/O status indicator:** LED turns on with closed contact.  
**Isolation:** I/O or sensor excitation to HLS to power input to FE  
**Data allocation:** 1

■ INPUT

**ON voltage / current:**  $\geq 15$  V DC (I/O's X0 through X7 to +24 V) /  $\geq 3.5$  mA  
**OFF voltage / current:**  $\leq 5$  V DC (I/O's X0 through X7 to +24 V) /  $\leq 1$  mA  
**Input current:**  $\leq 5.5$  mA per point at 24 V DC  
**Input resistance:** Approx. 4.4 k $\Omega$   
**ON delay:**  $\leq 0.5$  msec.  
**OFF delay:**  $\leq 0.5$  msec.

■ OUTPUT

**Rated output current:** 0.1 A per point, 0.8 A per common  
**Residual voltage:**  $\leq 1.2$  V  
**Leakage current:**  $\leq 0.1$  mA  
**ON delay:**  $\leq 0.5$  msec.  
**OFF delay:**  $\leq 0.5$  msec.  
**Overload current protection function:** Limits the current value when overcurrent is detected  
**Overheat Protection Function:**  
 Turns OFF the output when overheat is detected

PIN No	ID	FUN- TION	PIN No	ID	FUN- TION
X0	1	X0	Y0	1	Y0
	2	+24V		2	+24V
	3	GND		3	GND
X1	1	X1	Y1	1	Y1
	2	+24V		2	+24V
	3	GND		3	GND
X2	1	X2	Y2	1	Y2
	2	+24V		2	+24V
	3	GND		3	GND
X3	1	X3	Y3	1	Y3
	2	+24V		2	+24V
	3	GND		3	GND
X4	1	X4	Y4	1	Y4
	2	+24V		2	+24V
	3	GND		3	GND
X5	1	X5	Y5	1	Y5
	2	+24V		2	+24V
	3	GND		3	GND
X6	1	X6	Y6	1	Y6
	2	+24V		2	+24V
	3	GND		3	GND
X7	1	X7	Y7	1	Y7
	2	+24V		2	+24V
	3	GND		3	GND

**TERMINAL ASSIGNMENTS**

■ I/O Connection

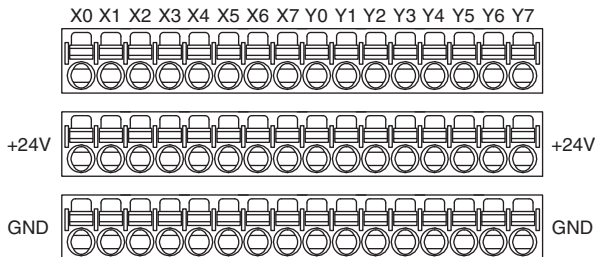

**SCHEMATIC CIRCUITRY**

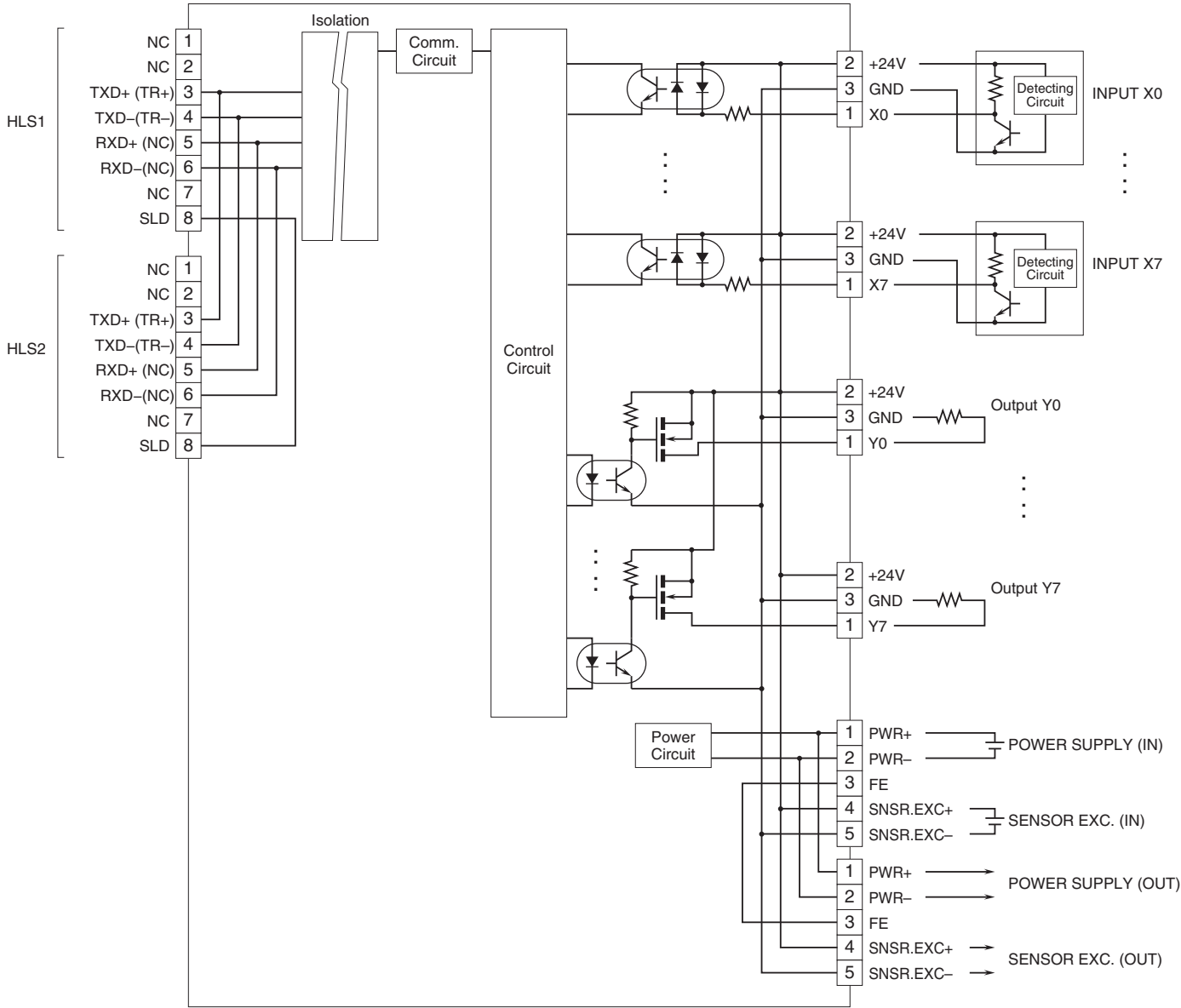

■ 2-Wire Sensor

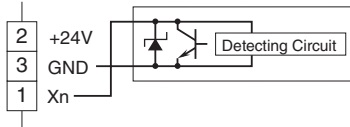

## NPN DISCRETE INPUT & NPN TRANSISTOR OUTPUT MODULE, 8 points each

(Tension clamp terminal block)

### MODEL: R7F4DH-4-DAC16C

#### SPECIFICATIONS

##### COMMON SPECIFICATIONS

- Input common:** Positive common per 8 points
- Output common:** Negative common per 8 points
- Input rating/load voltage:** 24 V DC  $\pm 10\%$ , ripple 5 %p-p max.
- Number of I/O:** Input, 8 points; Output, 8 points
- Maximum I/O applicable at once:** No limit (at 24 V DC)
- I/O status indicator:** LED turns on with closed contact.
- Isolation:** I/O or sensor excitation to HLS to power input to FE
- Data allocation:** 1
- ##### INPUT

  - ON voltage / current:**  $\geq 15$  V DC (I/O's X0 through X7 to +24 V) /  $\geq 3.5$  mA
  - OFF voltage / current:**  $\leq 5$  V DC (I/O's X0 through X7 to +24 V) /  $\leq 1$  mA
  - Input current:**  $\leq 5.5$  mA per point at 24 V DC
  - Input resistance:** Approx. 4.4 k $\Omega$
  - ON delay:**  $\leq 0.5$  msec.
  - OFF delay:**  $\leq 0.5$  msec.
- ##### OUTPUT

  - Rated output current:** 0.1 A per point, 0.8 A per common
  - Residual voltage:**  $\leq 1.2$  V
  - Leakage current:**  $\leq 0.1$  mA
  - ON delay:**  $\leq 0.5$  msec.
  - OFF delay:**  $\leq 0.5$  msec.
  - Overload current protection function:** Limits the current value when overcurrent is detected
  - Overheat Protection Function:** Turns OFF the output when overheat is detected

PIN No	ID	FUNCTION	PIN No	ID	FUNCTION
X0	1	X0	Y0	1	Y0
	2	+24V		2	+24V
	3	GND		3	GND
X1	1	X1	Y1	1	Y1
	2	+24V		2	+24V
	3	GND		3	GND
X2	1	X2	Y2	1	Y2
	2	+24V		2	+24V
	3	GND		3	GND
X3	1	X3	Y3	1	Y3
	2	+24V		2	+24V
	3	GND		3	GND
X4	1	X4	Y4	1	Y4
	2	+24V		2	+24V
	3	GND		3	GND
X5	1	X5	Y5	1	Y5
	2	+24V		2	+24V
	3	GND		3	GND
X6	1	X6	Y6	1	Y6
	2	+24V		2	+24V
	3	GND		3	GND
X7	1	X7	Y7	1	Y7
	2	+24V		2	+24V
	3	GND		3	GND

#### TERMINAL ASSIGNMENTS

##### I/O Connection

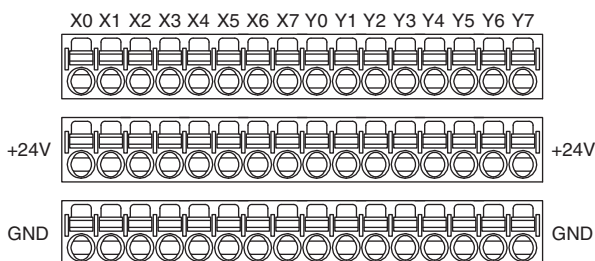

**SCHEMATIC CIRCUITRY**

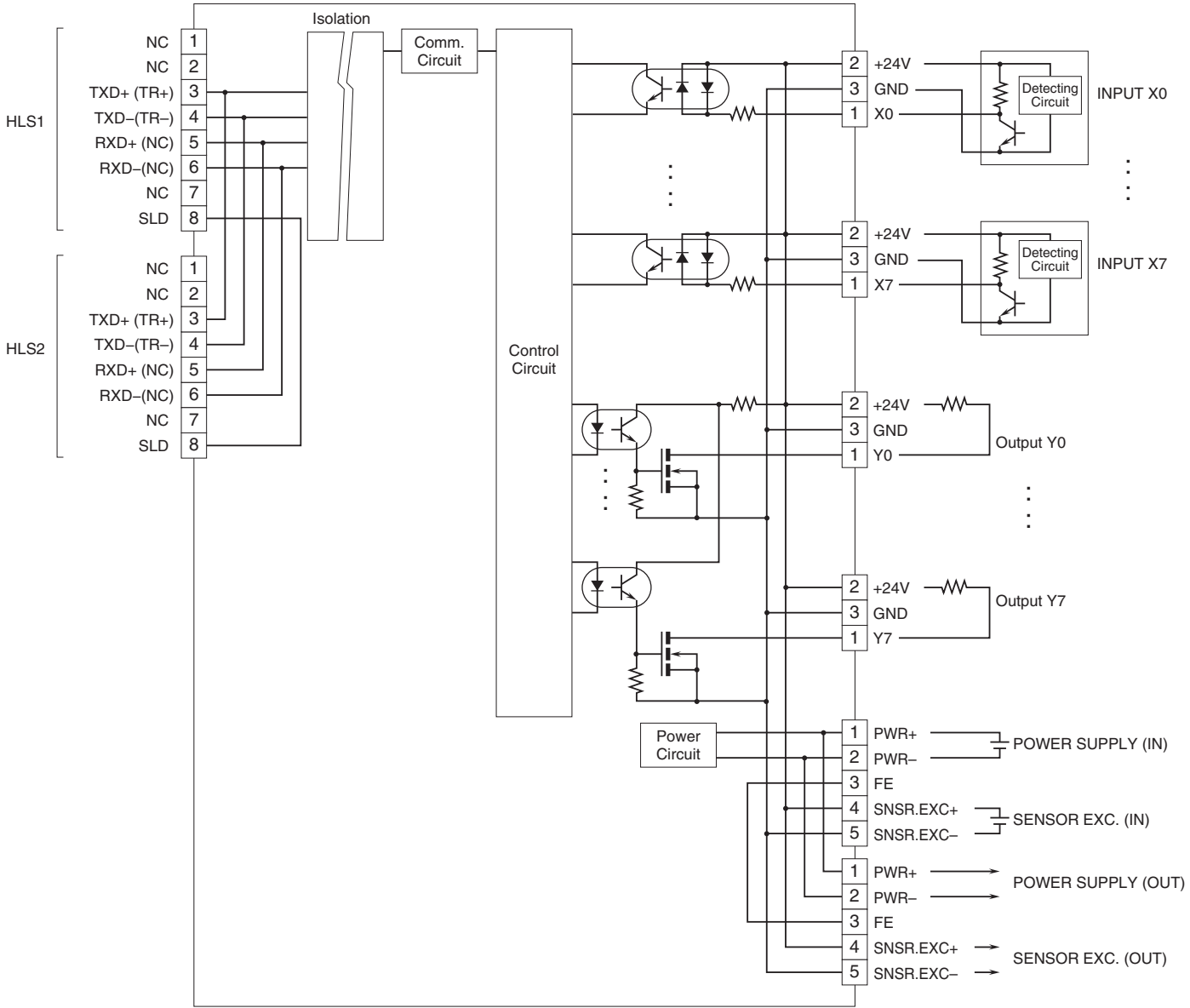

■ 2-Wire Sensor

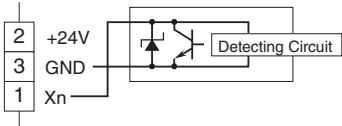

## PNP DISCRETE INPUT & PNP TRANSISTOR OUTPUT MODULE, 8 points each

(Tension clamp terminal block)

### MODEL: R7F4DH-4-DAC16D

#### SPECIFICATIONS

##### COMMON SPECIFICATIONS

**Input common:** Negative common per 8 points  
**Output common:** Positive common per 8 points  
**Input rating/load voltage:** 24 V DC  $\pm 10\%$ , ripple 5 %p-p max.

**Number of I/O:** Input, 8 points; Output, 8 points  
**Maximum I/O applicable at once:** No limit (at 24 V DC)  
**I/O status indicator:** LED turns on with closed contact.  
**Isolation:** I/O or sensor excitation to HLS to power input to FE

**Data allocation:** 1

##### INPUT

**ON voltage / current:**  $\geq 15$  V DC (I/O's X0 through X7 to 0 V)  
 $\geq 3.5$  mA

**OFF voltage / current:**  $\leq 5$  V DC (I/O's X0 through X7 to 0 V)  
 $\leq 1$  mA

**Input current:**  $\leq 5.5$  mA per point at 24 V DC

**Input resistance:** Approx. 4.4 k $\Omega$

**ON delay:**  $\leq 0.5$  msec.

**OFF delay:**  $\leq 0.5$  msec.

##### OUTPUT

**Rated output current:** 0.1 A per point, 0.8 A per common

**Residual voltage:**  $\leq 1.2$  V

**Leakage current:**  $\leq 0.1$  mA

**ON delay:**  $\leq 0.5$  msec.

**OFF delay:**  $\leq 0.5$  msec.

**Overload current protection function:** Limits the current value when overcurrent is detected

**Overheat Protection Function:**

Turns OFF the output when overheat is detected

PIN No	ID	FUNCTION	PIN No	ID	FUNCTION
X0	1	X0	Y0	1	Y0
	2	+24V		2	+24V
	3	GND		3	GND
X1	1	X1	Y1	1	Y1
	2	+24V		2	+24V
	3	GND		3	GND
X2	1	X2	Y2	1	Y2
	2	+24V		2	+24V
	3	GND		3	GND
X3	1	X3	Y3	1	Y3
	2	+24V		2	+24V
	3	GND		3	GND
X4	1	X4	Y4	1	Y4
	2	+24V		2	+24V
	3	GND		3	GND
X5	1	X5	Y5	1	Y5
	2	+24V		2	+24V
	3	GND		3	GND
X6	1	X6	Y6	1	Y6
	2	+24V		2	+24V
	3	GND		3	GND
X7	1	X7	Y7	1	Y7
	2	+24V		2	+24V
	3	GND		3	GND

#### TERMINAL ASSIGNMENTS

##### I/O Connection

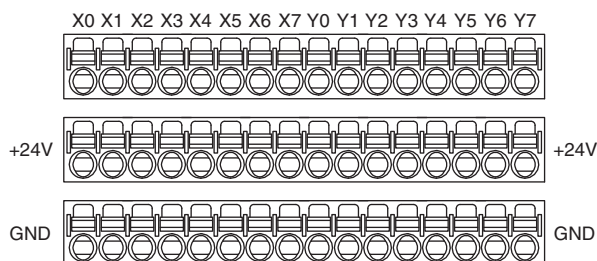

**SCHEMATIC CIRCUITRY**

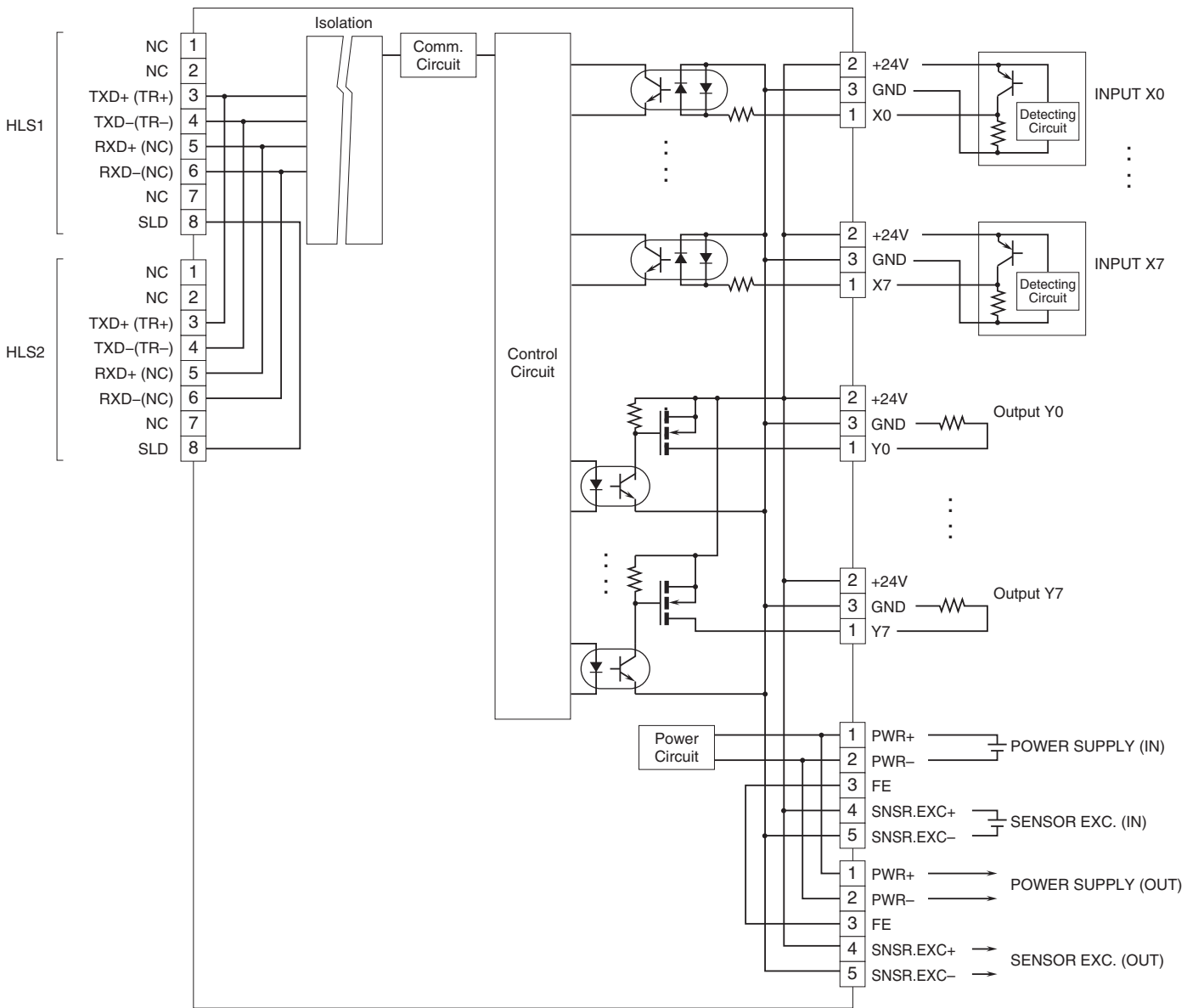

■ 2-Wire Sensor

