

Remote I/O RZMS Series

UNIVERSAL INPUT MODULE

(12 points; isolated)

Functions & Features

- 12-point universal inputs
- Channel-to-channel isolation
- Trigger input and alarm contact output
- Filtering protection against 50/60 Hz noise
- Modbus RS-485 and RS-232-C interface
- Easy system expansion via Modbus RTU

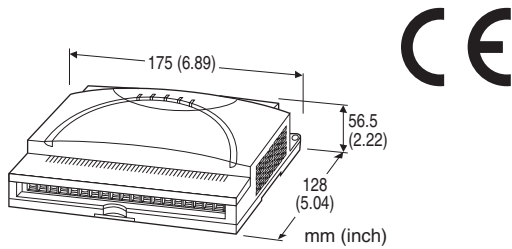

MODEL: RZMS-U9T-[1]

ORDERING INFORMATION

- Code number: RZMS-U9T-[1]

Specify a code from below for [1]

e.g. RZMS-U9T-M2

FIELD TERMINAL TYPE

T: M3 screw terminals

[1] POWER INPUT

AC Power

M2: 100 – 240 V AC (Operational voltage range 85 – 264 V, 47 – 66 Hz)

DC Power

R: 24 V DC

(Operational voltage range 24 V \pm 10 %, ripple 10 %p-p max.)

RELATED PRODUCTS

- Resistor module (model: REM3-250)

Though the REM3 is designed to be mounted directly to this model, we recommend that it be attached to a separate terminal board in order to eliminate its heat conduction to affect the cold junction compensation and the overall measuring accuracy of this model.

- RZXS configurator software (model: RZMSCFG)

Downloadable at M-System's web site.

A dedicated cable is required to connect the module to the

PC. Please refer to the internet software download site or the users manual for the PC configurator for applicable cable types.

GENERAL SPECIFICATIONS

Connection

Power input, transmission: Euro type connector terminal (wire size 0.14 – 1.5 mm² or AWG26 – 16 for both stranded and solid wires)

RS-232-C: 9-pin D-sub connector (male)

I/O: M3 screw terminals

PC Configurator: Miniature jack, RS-232-C level

Isolation: Input 1 to input 2 to input 3 to input 4 to input 5 to input 6 to input 7 to input 8 to input 9 to input 10 to input 11 to input 12 to trigger input to alarm output to RS-232-C or RS-485 or configurator jack to power to FG

Zero/span adjustments: Available with PC Configurator for all types of inputs.

Burnout for T/C and RTD input: Upscale, Downscale or No burnout selectable

Select 'No Burnout' to minimize the measuring errors caused by the sensor/wire resistance and the burnout sensing current.

With RTD input, the signal may go transiently to the opposite direction from the burnout setting.

With DC/potentiometer input, the burnout setting is ignored and the burnout sensing current is cancelled.

In order to specify burnout actions to individual channels, use PC Configurator Software.

Wire resistance compensation for RTD input: Field calibration for 3-wire (or 2-wire) RTD available with PC Configurator software.

Cold junction compensation (CJC) for T/C input: CJC can be enabled or disabled. Reference temperature is measured at the internal sensor by factory setting.

In order to specify cold junction compensation to individual channels, use PC Configurator Software.

Temperature measured at another channel of this model can be specified as the reference point by using PC Configurator Software. This is beneficial to reduce compensation wires' cost when there are many temperature points in remote locations.

Install a relaying terminal board near the sensors and use ordinary copper wires between the board and this model, and assign one channel to measure temperature at the terminal board as the reference.

Operating mode setting: Rotary switch; burnout type, cold junction compensation, line noise frequency, software filter, A/D conversion mode, service channel numbers setting available

Line noise filter: NMNR ratio to the line frequency and its harmonic contents can be optimized. Factory set to 50/60

Hz mode for use with both frequencies. Select either frequency for the most effective result.

Programmable first order lag filter: Time constant selectable with PC Configurator Software.

The use of this filter is disabled at the factory shipment. With the large time constant setting, measured signals during the warm-up immediately after the power is turned on may affect the signals for a long time period.

A/D conversion mode: Fast, Medium or Slow selectable with PC Configurator Software.

With Slow setting, data fluctuations are minimized with limited sampling time (speed).

With Fast setting, sampling time (speed) can be high though data fluctuations increase.

Address setting: Rotary switch; 1 - F (15 nodes)

Indicator LEDs: Five (5) LEDs indicate the module's operating conditions.

Service channel numbers: 12 channels (ch.1 thr. 12) or 6 channels (ch.1 thr. 6) are selectable with PC Configurator. Factory set to 12 channels.

COMMUNICATION

Baud rate: 38.4 kbps

Communication: Half-duplex, asynchronous, no procedure

Protocol: Modbus RTU

Refer to Modbus Protocol Reference Guide (EM-5650) for supported functions.

■ RS-232-C

Standard: Conforms to RS-232-C, EIA

Transmission distance: 10 meters max.

■ RS-485

Standard: Conforms to RS-485, EIA

Transmission distance: 500 meters max.

Transmission media: Shielded twisted-pair cable (CPEV-S 0.9 dia.)

INPUT SPECIFICATIONS

• DC Voltage

Input resistance: 900 kΩ min.

Excluding the case in which, with range setting other than ± 12 V, ± 6 V or ± 3 V, a voltage exceeding ± 1.3 V is applied.

Input range: ± 60 mV, ± 125 mV, ± 250 mV, ± 500 mV, ± 1000 mV, ± 3 V, ± 6 V, ± 12 V

■ THERMOCOUPLE

Input resistance: 900 kΩ minimum

Input type: (PR), K (CA), E (CRC), J (IC), T (CC), B (RH), R, S, C (WRe 5-26), N, U, L, P (Platinel II)

Burnout sensing

Upscale: ≤ 130 nA

Downscale: ≤ 220 nA

No burnout: ≤ 10 nA

Burnout sensing time

K, E, J, N, L, P (upscale): ≤ 20 seconds

Others: ≤ 10 seconds

■ RTD (3-wire)

Excitation: 1.25 V / (1.25 kΩ + load resistance across the terminals A - C); 1.00 mA with 10 Ω across A - C; 0.55 mA with 1000 Ω across A - C

Allowable leadwire resistance: 20 Ω per wire

Input type: Pt 100 (JIS '89), Pt 100 (JIS '97, IEC), Pt 200, Pt 300, Pt 400, Pt 500, Pt 1000, Pt 50Ω (JIS '81), JPt 100 (JIS '89), Ni 100, Ni 120, Ni 508.4Ω, Ni-Fe 604, Cu 10 @ 25°C

Burnout sensing

Upscale or Downscale: ≤ 130 nA

No burnout: ≤ 10 nA

Burnout sensing time: ≤ 10 seconds

■ POTENTIOMETER

Excitation: 1.25 V / (1.31 kΩ + load resistance across the terminals A - C); 0.83 mA with 200 Ω across A - C; 0.20 mA with 5 kΩ across A - C

Allowable leadwire resistance: 20 Ω per wire

Total resistance: See Potentiometer Input Table of the "Input type, Range, Accuracy & Temperature Coefficient" section.

■ TRIGGER INPUT: Dry contact; detected ON at ≤ 0.8 V

Voltage across the terminals: ≤ 2.5 V

Current across the terminals: ≤ 4.0 mA

■ SAMPLING TIME

LINE NOISE FILTER FREQ.	SERVICE CH. NO.	A/D CONVERSION (sec)		
		MEDIUM	SLOW	FAST
50 Hz	12 ch	0.68	0.94	0.43
	6 ch	0.38	0.53	0.26
50/60 Hz	12 ch	0.63	0.87	0.40
	6 ch	0.35	0.49	0.24
60 Hz	12 ch	0.59	0.80	0.38
	6 ch	0.33	0.45	0.22

Multipled by two (2) for RTD and potentiometer input.

OUTPUT SPECIFICATIONS

■ ALARM OUTPUT: Photo MOSFET relay (no polarity); ≤ 50 Ω at ON, ≥ 1 MΩ at OFF; OFF when not powered

Peak load voltage: 50 V max.

Continuous load current: 50 mA max.

Peak load current: 300 mA max. (≤ 0.1 sec.)

INSTALLATION

Power Consumption

•AC: Approx. 5 VA

•DC: Approx. 1.2 W

Operating temperature: -5 to +60°C (23 to 140°F)

Operating humidity: 30 to 90 %RH (non-condensing)

Mounting: Surface or DIN rail

Weight: 520 g (1.15 lbs)

PERFORMANCE

Accuracy: See "Input type, Range, Accuracy & Temperature Coefficient" section.

Cold junction compensation error: (°C)

$\leq \pm[0.6 + |\text{Ambient Temp.} - 25| \times 0.04]$

(in stable ambient temperature; e.g. $\pm 1.0^\circ\text{C}$ at 15°C and 35°C)

Applicable with balanced terminal temperature.

Error will increase by imbalances caused by direct mounting of the REM3 to the terminals.

Temp. coefficient: See "Input type, Range, Accuracy & Temperature Coefficient" section.

Response time (Assuming the fastest reading on Modbus)

• **DC of ± 1000 mV or narrower ranges or T/C:**

$\leq [\text{Sampling Time} + 0.3 \text{ sec.}] (0 - 90 \%)$

• **DC of ± 3 V or wider ranges:**

$\leq [\text{Sampling Time} + 0.5 \text{ sec.}] (0 - 90 \%)$

• **RTD or potentiometer:**

$\leq [\text{Sampling Time} + 0.3 \text{ sec.}] (0 - 90 \%)$

Insulation resistance: $\geq 100 \text{ M}\Omega$ with 500 V DC

Dielectric strength: 500 V_{peak} @1 minute

(input 1 to input 2 to input 3 to input 4 to input 5 to input 6 to input 7 to input 8 to input 9 to input 10 to input 11 to input 12 to trigger input to alarm output to RS-232-C or RS-485 or configurator jack to power or FG)

2000 V AC @ 1 minute (power to FG)

Note: Peak value including both AC and DC (e.g. 354 V AC with 0 V DC).

Though the withstand voltage is limited to 500 V_{peak} between the I/O (analog inputs, trigger input or alarm output) and the power input, there will be no dielectric breakdown between the I/O (with or without grounding) and other terminals even when 2000 V AC is applied across FG and the power input if the earth terminal is adequately grounded.

Line noise normal mode rejection: ≥ 100 dB

Magnitude of the effects of normal mode 50/60 Hz noise, with the most appropriate line noise filter frequency setting. Each input circuit has a CR filter of sufficient large time constant so that there will be little effect of line noise such as 500 mV AC superposed on a thermocouple or ± 60 mV input.

Common mode noise rejection

Magnitude of the effects of voltages applied across the terminal C and the ground terminal when there is no potential difference among all the C terminals.

DC: N/A

AC, ± 3 V, ± 6 V, ± 12 V: Approx. 86 dB

AC, other ranges: Approx. 120 dB

Common mode noise rejection between channels:

Magnitude of the effects of DC/50/60 Hz voltages applied across the terminals C of the present and the last scanned channels. (Data are scanned from ch 1 to ch 12 in turn and back to ch 1 again.)

DC, ± 3 V, ± 6 V, ± 12 V: Approx. 100 dB

DC, other ranges: Approx. 120 dB

AC, ± 3 V, ± 6 V, ± 12 V: Approx. 86 dB

AC, other ranges: Approx. 106 dB

High common mode noise between channels may compromise the accuracies in low millivolts measuring including thermocouple input.

We recommend that C terminals of each channel be cross-wired and then connected to the ground terminal to ensure the measurement of the highest accuracy.

If such configuration is not possible, take special consideration to minimize the channel-to-channel common mode noise and the potential against the ground terminal. The potential of the open terminal C against the ground terminal equals to that of the last scanned channel. If ch 2 and ch 3 are not connected, the accuracy of ch 4 measurement is affected by potential difference between the C terminals of ch 1 and ch 4.

STANDARDS & APPROVALS

CE conformity:

EMC Directive (2004/108/EC)

EMI EN 61000-6-4: 2007

EMS EN 61000-6-2: 2005

Low Voltage Directive (2006/95/EC)

EN 61010-1

Installation Category II

Pollution Degree 2

Power input to input or output: Reinforced insulation (300 V)

INPUT TYPE, RANGE, ACCURACY & TEMPERATURE COEFFICIENT

Applicable with the common mode voltage 0 V between C terminals of all channels and between C terminal of each channel and the ground terminal.

The effects by the following factors are excluded:

Fast A/D conversion mode; temperature drift with the REM3 directly mounted to the I/O terminals; wire resistance; burnout sensing current with upscale/downscale settings.

DC Voltage Input

INPUT RANGE	ACCURACY (mV)
±60mV	±0.05
±125mV	±0.07
±250mV	±0.13
±500mV	±0.25
±1000mV	±0.5
±3V	±2.5
±6V	±5
±12V	±10

Thermocouple Input, Celsius

T/C	USABLE RANGE (°C)	CONFORMANCE RANGE (°C)	ACCURACY (°C)
(PR)	0 to 1770	400 to 1770	±4.6
K (CA)	-270 to +1370	0 to 1370	±1.5
E (CRC)	-270 to +1000	0 to 1000	±0.8
J (IC)	-210 to +1200	0 to 1200	±1.0
T (CC)	-270 to +400	0 to 400	±1.3
B (RH)	100 to 1820	700 to 1820	±7.2
R	-50 to +1760	400 to 1760	±4.8
S	-50 to +1760	400 to 1760	±5.3
C (WRe 5-26)	0 to 2320	0 to 2320	±4.9
N	-270 to +1300	0 to 1300	±1.9
U	-200 to +600	0 to 600	±1.3
L	-200 to +900	0 to 900	±1.0
P (Platinel II)	0 to 1395	0 to 1395	±1.7

Thermocouple Input, Fahrenheit

T/C	USABLE RANGE (°F)	CONFORMANCE RANGE (°F)	ACCURACY (°F)
(PR)	32 to 3218	752 to 3218	±8.28
K (CA)	-454 to +2498	32 to 2498	±2.7
E (CRC)	-454 to +1832	32 to 1832	±1.44
J (IC)	-346 to +2192	32 to 2192	±1.8
T (CC)	-454 to +752	32 to 752	±2.34
B (RH)	212 to 3308	1292 to 3308	±13.0
R	-58 to +3200	752 to 3200	±8.64
S	-58 to +3200	752 to 3200	±9.54
C (WRe 5-26)	32 to 4208	32 to 4208	±8.82
N	-454 to +2372	32 to 2372	±3.42
U	-328 to +1112	32 to 1112	±2.34
L	-328 to +1652	32 to 1652	±1.8
P (Platinel II)	32 to 2543	32 to 2543	±3.06

Note 1: Measuring accuracy at 50µV emf.

Note 2: CJC error is not included.

RTD Input, Celsius

RTD	USABLE RANGE (°C)	ACCURACY	
		at ≤ 0°C	at ≥ 0°C
Pt 100 (JIS '97, IEC)	-200 to +850	±0.4°C	±[0.4°C + Measured Value × 0.1%] (±1.3°C at 850°C)
Pt 200	-200 to +850	±0.3°C	±[0.3°C + Measured Value × 0.17%] (±1.8°C at 850°C)
Pt 300	-200 to +850	±[0.4°C + Measured Value × 0.08%] (±0.24°C at -200°C)	±[0.4°C + Measured Value × 0.21%] (±2.2°C at 850°C)
Pt 400	-200 to +850	±[0.4°C + Measured Value × 0.11%] (±0.18°C at -200°C)	±[0.4°C + Measured Value × 0.21%] (±2.2°C at 850°C)
Pt 500	-200 to +850	±[0.4°C + Measured Value × 0.13%] (±0.14°C at -200°C)	±[0.4°C + Measured Value × 0.26%] (±2.6°C at 850°C)
Pt 1000	-200 to +850	±[0.4°C + Measured Value × 0.15%] (±0.10°C at -200°C)	±[0.4°C + Measured Value × 0.4%] (±3.8°C at 850°C)
Pt 100 (JIS '89)	-200 to +660	±0.4°C	±[0.4°C + Measured Value × 0.1%] (±1.1°C at 650°C)
JPt 100 (JIS '89)	-200 to +510	±0.4°C	±[0.4°C + Measured Value × 0.1%] (±0.91°C at 510°C)
Pt 50Ω (JIS '81)	-200 to +649	±0.5°C at ≤160°C, ±[0.4°C + Measured Value × 0.1%] at ≥160°C (±1.049°C at 649°C)	
Ni 100	-80 to +260	±0.3°C	
Ni 120	-80 to +260	±0.3°C	
Ni 508.4Ω	-50 to +280	±[0.25°C + Measured Value × 0.06%] (±0.22°C at -50°C, ±0.42°C at 280°C)	
Ni-Fe 604	-200 to +200	±0.9°C at -200°C, ±0.6°C at -150°C, ±0.5°C at ±100°C, ±0.7°C at 200°C	
Cu 10 @25°C	-50 to +250	±1.2°C (only after the field calibrations)	

RTD Input, Fahrenheit

RTD	USABLE RANGE (°F)	ACCURACY	
		at ≤ 32°F	at ≥ 32°F
Pt 100 (JIS '97, IEC)	-328 to +1562	±0.72°F	±[0.72°F + Measured Value × 0.1%] (±2.34°F at 1562°F)
Pt 200	-328 to +1562	±0.54°F	±[0.54°F + Measured Value × 0.17%] (±3.24°F at 1562°F)
Pt 300	-328 to +1562	±[0.72°F + Measured Value × 0.08%] (±0.44°F at -328°F)	±[0.72°F + Measured Value × 0.21%] (±4.0°F at 1562°F)
Pt 400	-328 to +1562	±[0.72°F + Measured Value × 0.11%] (±0.33°F at -328°F)	±[0.72°F + Measured Value × 0.21%] (±3.96°F at 1562°F)
Pt 500	-328 to +1562	±[0.72°F + Measured Value × 0.13%] (±0.26°F at -328°F)	±[0.72°F + Measured Value × 0.26%] (±4.68°F at 1562°F)
Pt 1000	-328 to +1562	±[0.72°F + Measured Value × 0.15%] (±0.18°F at -328°F)	±[0.72°F + Measured Value × 0.4%] (±6.84°F at 1562°F)
Pt 100 (JIS '89)	-328 to +1220	±0.72°F	±[0.72°F + Measured Value × 0.1%] (±1.98°F at 1220°F)
JPt 100 (JIS '89)	-328 to +950	±0.72°F	±[0.72°F + Measured Value × 0.1%] (±1.64°F at 950°F)
Pt 50Ω (JIS '81)	-328 to +1200	±0.9°F at ≤320°F, ±[0.72°F + Measured Value × 0.1%] at ≥320°F (±1.888°F at 1200°F)	
Ni 100	-112 to +500	±0.54°F	
Ni 120	-112 to +500	±0.54°F	
Ni 508.4Ω	-58 to +536	±[0.45°F + Measured Value × 0.06%] (±0.40°F at -58°F, ±0.76°F at 536°F)	
Ni-Fe 604	-328 to +392	±1.62°F at -328°F, ±1.08°F at -238°F, ±0.9°F at ±212°F, ±1.26°F at 392°F	
Cu 10 @25°C	-58 to +482	±2.16°F (only after the field calibrations)	

Note 1: The lower the temperature range, the better the accuracy is for Pt 300, Pt 400, Pt 500, Pt 1000 and Ni 508.4Ω.

'Measured Value' in the equations is not an absolute value. Include the minus sign when calculating accuracies.

Note 2: For Cu 10 @25°C, be sure to perform the field calibrations of wire imbalance and zero/span by using the PC Configurator software.

Potentiometer Input

TOTAL RESISTANCE	ACCURACY
Up to 200Ω	±0.12% at 200Ω
Up to 500Ω	±0.14% at 500Ω
Up to 5kΩ	±0.14% at 1kΩ ±0.10% at 2kΩ or 5kΩ

Temperature Coefficient

INPUT TYPE	TEMPERATURE COEFFICIENT	
DC Voltage	±[Nominal Input Range × 0.015%]/°C or ±[Nominal Input Range × 0.008%]/°F (e.g. ±0.018mV/°C with ±60mV range)	
Thermocouple	±[Accuracy / 3] °C/°C or ±[Accuracy / 3] °F/°F (e.g. ±0.27°C/°C with E thermocouple)	
RTD	at ≤ 0°C or 32°F	at ≥ 0°C or 32°F
Pt 100 (JIS '97, IEC)	±0.041°C/°C ±0.041°F/°F	±[0.041°C + Measured Value × 0.026%]/°C ±[0.041°F + Measured Value × 0.026%]/°F
Pt 200	±0.044°C/°C ±0.044°F/°F	±[0.044°C + Measured Value × 0.033%]/°C ±[0.044°F + Measured Value × 0.033%]/°F
Pt 300	±0.047°C/°C ±0.047°F/°F	±[0.047°C + Measured Value × 0.04%]/°C ±[0.047°F + Measured Value × 0.04%]/°F
Pt 400	±0.05°C/°C ±0.05°F/°F	±[0.05°C + Measured Value × 0.052%]/°C ±[0.05°F + Measured Value × 0.052%]/°F
Pt 500	±0.053°C/°C ±0.053°F/°F	±[0.053°C + Measured Value × 0.053%]/°C ±[0.053°F + Measured Value × 0.053%]/°F
Pt 1000	±[0.068°C + Measured Value × 0.025%]/°C ±[0.068°F + Measured Value × 0.025%]/°F	±[0.068°C + Measured Value × 0.087%]/°C ±[0.068°F + Measured Value × 0.087%]/°F
Pt 100 (JIS '89)	±0.041°C/°C ±0.041°F/°F	±[0.041°C + Measured Value × 0.024%]/°C ±[0.041°F + Measured Value × 0.024%]/°F
JPt 100 (JIS '89)	±0.041°C/°C ±0.041°F/°F	±[0.041°C + Measured Value × 0.023%]/°C ±[0.041°F + Measured Value × 0.023%]/°F
Pt 50 (JIS '81)	±0.039°C/°C ±0.039°F/°F	±[0.039°C + Measured Value × 0.021%]/°C ±[0.039°F + Measured Value × 0.021%]/°F
Ni 100	±0.028°C/°C ±0.028°F/°F	±[0.028°C + Measured Value × 0.01%]/°C ±[0.028°F + Measured Value × 0.01%]/°F
Ni 120	±0.028°C/°C ±0.028°F/°F	±[0.028°C + Measured Value × 0.01%]/°C ±[0.028°F + Measured Value × 0.01%]/°F
Ni 508.4Ω	±0.046°C/°C ±0.046°F/°F	±[0.046°C + Measured Value × 0.018%]/°C ±[0.046°F + Measured Value × 0.018%]/°F
Ni-Fe 604	±0.058°C/°C at ≤-200°C, ±0.043°C/°C at -150°C, ±0.04°C/°C at -100°C, ±[0.047°C + Measured Value × 0.023%]/°C at ≥0°C ±0.058°F/°F at ≤-328°F, ±0.043°F/°F at -238°F, ±0.04°F/°F at -148°F, ±[0.047°F + Measured Value × 0.023%]/°F at ≥32°F	
Cu 10 @25°C	±0.07°C/°C or ±0.07°F/°F	
Potentiometer	±0.005%/°C or ±0.003%/°F	

EXTERNAL VIEW

TOP VIEW

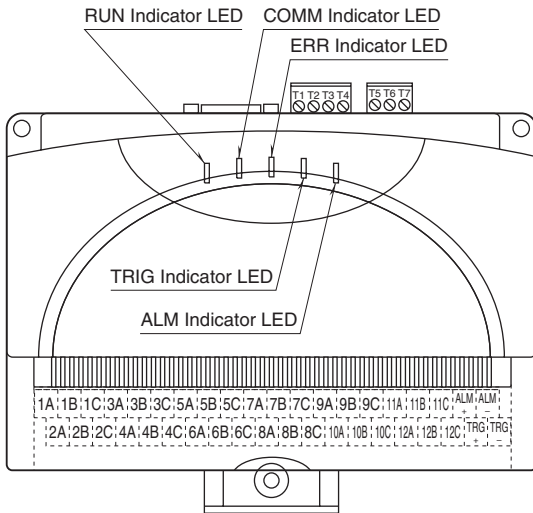

REAR VIEW

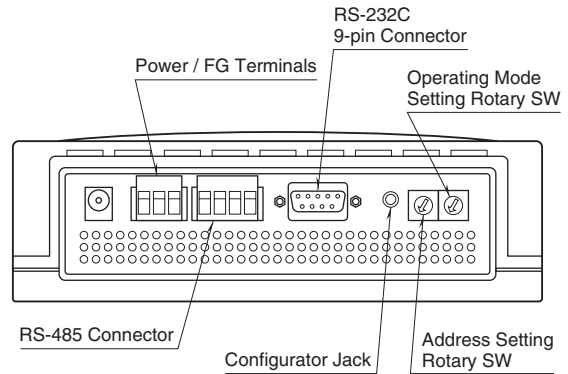

INDICATOR LED

- RUN: Green LED blinks when the internal microprocessor is operating normally.
- COMM: Communication LED. Amber light turns on when the RZMS is receiving normal data query frames from Modbus and sending responses out.
- ERR: Error LED. Red light turns on with internal errors and blinks when the RZMS is receiving abnormal data query frames from Modbus.
- TRG: Trigger LED. Amber light turns on when the trigger contact input turns on.
- ALM: Alarm LED. Amber light turns on when the alarm contact output turns on.

RS-232-C INTERFACE



ABBR.	PIN NO.	EXPLANATION OF FUNCTION
BA (SD)	2	Transmitted Data
BB (RD)	3	Received Data
AB (SG)	5	Signal Common
CB (CS)	7	Clear to Send
CA (RS)	8	Request to Send
	1	Not Used.
	4	DO NOT connect. Connecting may cause malfunctions.
	6	
	9	

RS-232-C CABLE

- Use a 'Straight' cable to connect this model to a PC if not with the cable included in the product package.
- For connecting this model to the R1M or the R2K-1 via RS-232-C, the RS-232-C cable must satisfy the following conditions:
 - Includes the connections shown with solid lines in the figure below.
 - Pins No. 8 are not connected between each other. (May cause breakdowns.)
 'Interlink' or 'Reverse' cables are usually applicable.

Pin Assignments

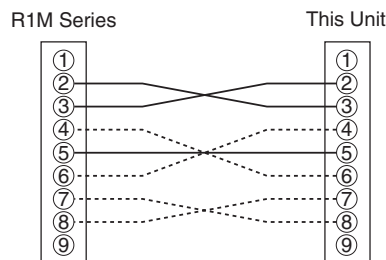

The above connection including solid and broken lines is an example of 'Interlink' cable.

CONNECTION DIAGRAM

Note: In order to improve EMC performance, bond the FG terminal to ground.

Caution: FG terminal is NOT a protective conductor terminal.

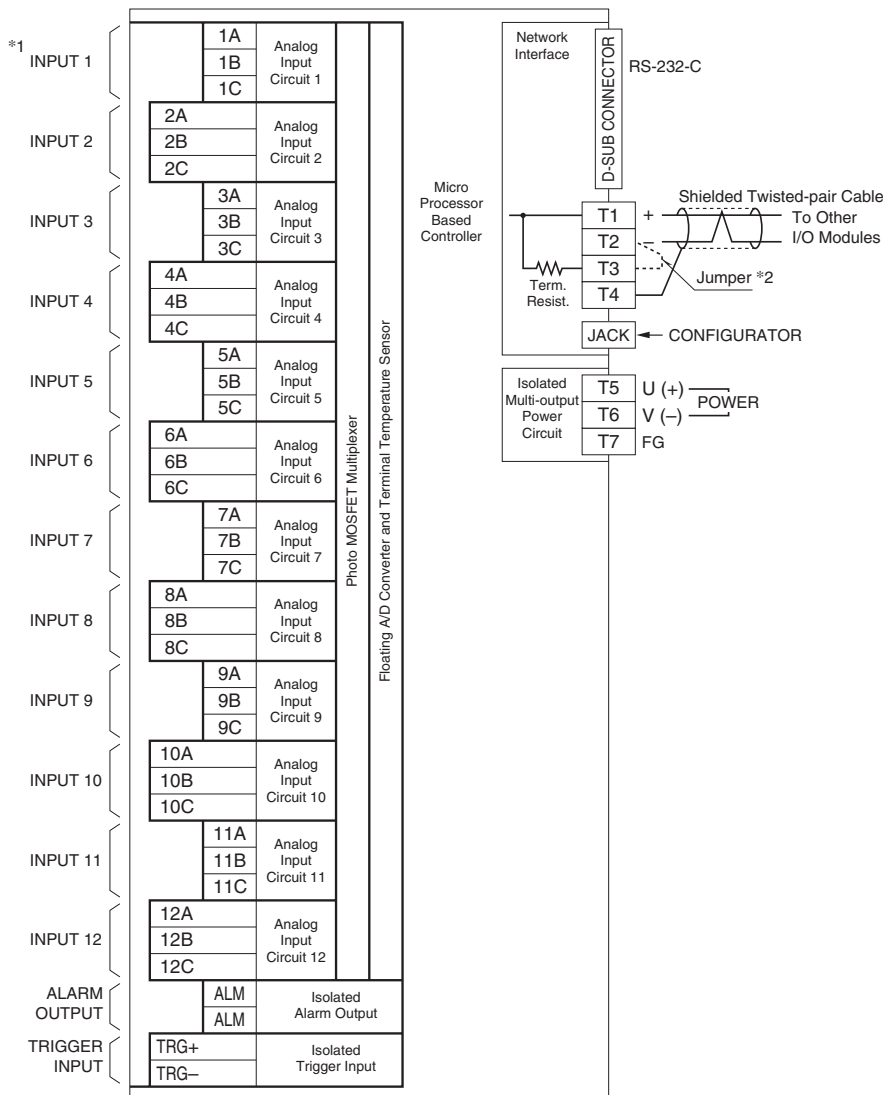

*1 Input Connection Examples

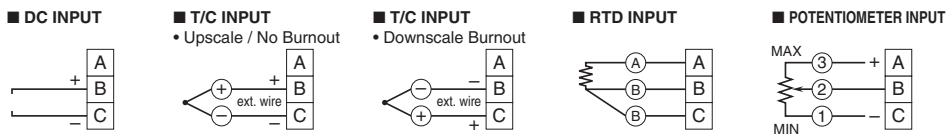

*2 When the device is located at the end of a transmission line via twisted-pair cable, (when there is no cross-wiring), close across the terminal T2 – T3 with the attached jumper pin (or with a leadwire).
When the device is not at the end, remove the jumper pin.

Remark 1: In order to protect the RZMS-U9 module and connected devices in connecting/disconnecting Modbus cable or the configurator cable, be sure to earth FG terminals of the RZMS-U9 and the connected device to a most stable earth point in the environment. Grounding is also effective to eliminate problems caused by noises.

Remark 2: Be careful to eliminate noise as much as possible by e.g. using shielded cables.

Remark 3: The smaller is common mode voltage (DC and AC) between C terminals and between C and FG, the better is measuring accuracy. Connecting between C terminals and if possible to FG will yield the best accuracy.

Remark 4: Resistor modules (model: REM3-250) can be connected to 1A through 12C terminals to convert current inputs into voltage. However, it is not recommended when TC inputs are mixed because the heat developed on and around the REM3 affects the cold junction compensation performance. We recommend that REM3 be connected on a separate terminal board.

Remark 5: When the internal temperature sensors are used for CJC, temperature imbalance around the terminal block affects greatly the CJC accuracy. In order to minimize such imbalance, do not use wires of large diameter which has large heat dissipation. Be sure to close the terminal cover. Do not expose the module directly in the line of wind from a cooling fan.

Remark 6: Two-wire RTD can be used by closing across B and C terminals. Be sure to compensate wire resistance by Configurator Software.

MODBUS COMMUNICATION

■ COMMUNICATION PARAMETERS

PARAMETER	SPECIFICATION
Data Mode	RTU
Baud Rate	9600 / 19200 / 38400 (*) bps
Parity	None / Odd (*) / Even
Bit Length	8
Stop Bit	1 (*) / 2
Node Address	1 (*) to 15
Floating Point Data Interface	Normal (*) / Swapped
	RS-232-C/ RS-485

(*) Ex-factory setting

■ FUNCTION CODES & SUPPORTED CODES

CODE	NAME		
01	Read Coil Status	X	Digital output from the slave
02	Read Input Status	X	Status of digital inputs to the slave
03	Read Holding Registers	X	General purpose register within the slave
04	Read Input Registers	X	Collected data from the field by the slave
05	Force Single Coil	X	Digital output from the slave
06	Preset Single Registers	X	General purpose register within the slave
07	Read Exception Status		
08	Diagnostics		
09	Program 484		
10	Poll 484		
11	Fetch Comm. Event Counter		Fetch a status word and an event counter
12	Fetch Comm. Event Log		A status word, an event counter, a message count and a field of event bytes
13	Program Controller		
14	Poll Controller		
15	Force Multiple Coils	X	Digital output from the slave
16	Preset Multiple Registers	X	General purpose register within the slave
17	Report Slave ID		Slave type / 'RUN' status
18	Program 884/M84		
19	Reset Comm. Link		
20	Read General Reference		
21	Write General Reference		
22	Mask Write 4X Register		
23	Read/Write 4X Register		
24	Read FIFO Queue		

■ DATA ADDRESS

	ADDRESS	DATA FORMAT	NAME
Coil (0X)	1	bit	Alarm output
	33 - 44	bit	Cold junction compensation SW
Input Status (1X)	1	bit	Trigger contact input
	33 - 44	bit	ADC overrange
Input Register (3X)	1 - 12	I	Analog input, integer
	17 - 40	F	Analog input, floating point (engineering unit value V, °C, %)
	49 - 72	F	Terminal temperature per channel (°C)
	81 - 92	I	Channel status
	201 - 224	F	Analog input, raw data (V, Ω, %)
	302	I	Mode switch setting
	513	I	Analog input status
	514 - 521	B16	Model No.
	522 - 529	B16	Serial No.
	530 - 537	B16	Hardware version No.
Holding Register (4X)	538 - 545	B16	Firmware version No.
	49 - 72	F	Input filter time constant per channel (seconds)
	145 - 156	I	Input type No. per channel
	161 - 172	I	Burnout type per channel
	573	I	Line noise filtering frequency

bit = 1 bit, I = 16-bit integer, F = 32-bit floating, B16 = 16-byte character

Accessing addresses other than described above may affect the device operation or cause errors.

EXTERNAL DIMENSIONS & TERMINAL ASSIGNMENTS unit: mm (inch)

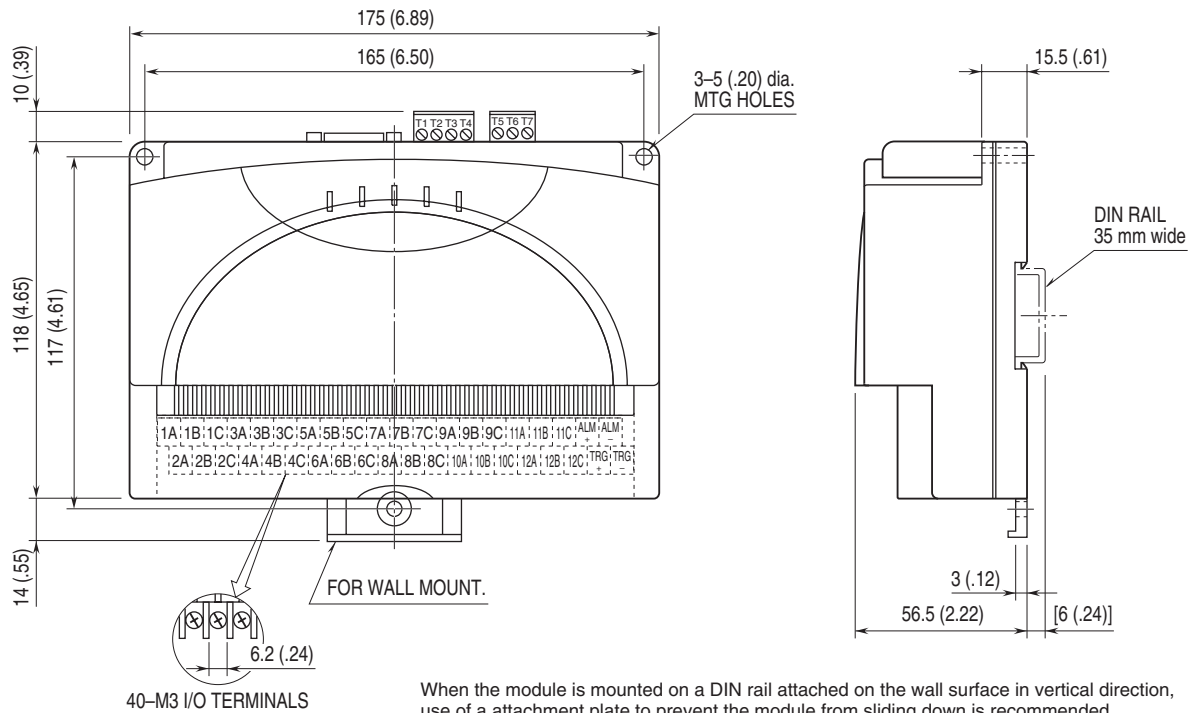

SYSTEM CONFIGURATION EXAMPLES

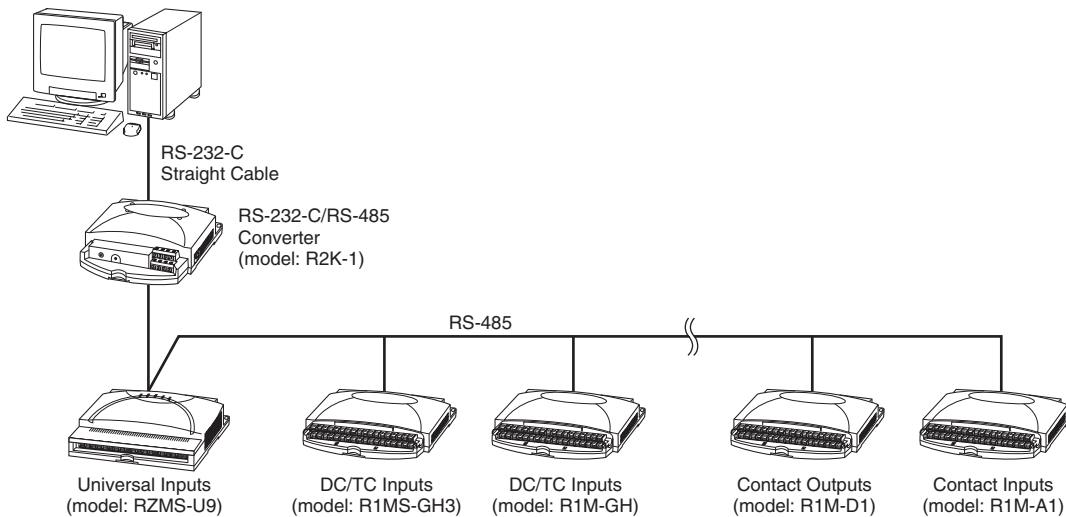

When the cable distance between the PC and the I/O modules is long, insert an RS-232-C/RS-485 Converter for isolation.



Specifications are subject to change without notice.