

Super-mini Terminal Block Signal Conditioners M5-UNIT

CT TRANSMITTER

(clamp-on current sensor)

Functions & Features

- Converts an alternating current into a standard process signal
- Easy-to-install clamp-on type current sensor without needing a current transformer
- Clamp-on current sensor included
- Wide input range from 10 A up to 600 A
- True RMS sensing
- High-density mounting
- Power LED

Typical Applications

- Centralized monitoring and control of motors at a supervisory panel
- Monitoring abnormal load current at motors to detect pump malfunctions

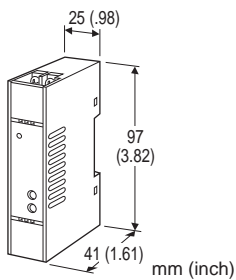

MODEL: M5CTC-[1][2][3]-[4][5]

ORDERING INFORMATION

Specify a code from below for each [1] through [5].

- Code number: M5CTC-[1][2][3]-[4][5]
(e.g. M5CTC-150A-R/Q)

Specify variables.

- Special output range (For codes Z & 0)

[1] SENSOR

- 1: Leadwire type CLSA
- 2: Screw terminal type CLSB

[2] INPUT

- 10: 0 - 10 A AC
- 15: 0 - 15 A AC
- 20: 0 - 20 A AC
- 30: 0 - 30 A AC
- 40: 0 - 40 A AC

50: 0 - 50 A AC

60: 0 - 60 A AC

75: 0 - 75 A AC

100: 0 - 100 A AC

125: 0 - 125 A AC

150: 0 - 150 A AC

175: 0 - 175 A AC

200: 0 - 200 A AC

225: 0 - 225 A AC

250: 0 - 250 A AC

300: 0 - 300 A AC

350: 0 - 350 A AC

400: 0 - 400 A AC

500: 0 - 500 A AC

600: 0 - 600 A AC (Not selectable with the sensor type code 1 'Leadwire type CLSA')

[3] OUTPUT

Current

A: 4 - 20 mA DC (Load resistance 550 Ω max.)

Z: Specify current (See OUTPUT SPECIFICATIONS)

Voltage

4: 0 - 10 V DC (Load resistance 1000 Ω min.)

5: 0 - 5 V DC (Load resistance 500 Ω min.)

6: 1 - 5 V DC (Load resistance 500 Ω min.)

4W: -10 - +10 V DC (Load resistance 8000 Ω min.)

5W: -5 - +5 V DC (Load resistance 4000 Ω min.)

0: Specify voltage (See OUTPUT SPECIFICATIONS)

[4] POWER INPUT

AC Power

M: 85 - 264 V AC (Operational voltage range 85 - 264 V, 47 - 66 Hz)

DC Power

R: 24 V DC

(Operational voltage range 24 V \pm 10 %, ripple 10 %p-p max.)

[5] OPTIONS

blank: none

/Q: With options (specify the specification)

SPECIFICATIONS OF OPTION: Q

COATING (For the detail, refer to M-System's web site.)

/C01: Silicone coating

/C02: Polyurethane coating

/C03: Rubber coating

ACCESSORIES

The clamp-on current sensor is included in the product package.

■ CLAMP-ON CURRENT SENSOR (leadwire type CLSA)

- 0 – 10 A through 0 – 75 A Use

Sensor model No.: CLSA-08

Sensor cable model No.: CLSA-08C-30

Applicable cable diameter: Max. 10.0

Sensor leadwire: AWG 22

Weight: 45 g (1.6 oz)

- 0 – 100 A Use

Sensor model No.: CLSA-12

Sensor cable model No.: CLSA-08C-30

Applicable cable diameter: Max. 16.0

Sensor leadwire: AWG 22

Weight: 70 g (2.5 oz)

- 0 – 125 A through 0 – 300 A Use

Sensor model No.: CLSA-30

Applicable cable diameter: Max. 24.0

Sensor leadwire: AWG 18, 200 mm

Weight: 200 g (7.1 oz)

- 0 – 350 A through 0 – 500 A Use

Sensor model No.: CLSA-50

Applicable cable diameter: Max. 36.0

Sensor leadwire: AWG 18, 200 mm

Weight: 300 g (10.6 oz)

■ CLAMP-ON CURRENT SENSOR (screw terminal type CLSB)

Connection: M3 screw terminal (torque 0.5 N·m)

Screw terminal: Nickel-plated steel

Output wiring: Use AWG22 or thicker wires for the output.

Twist the paired wires, extendable up to 30 meters.

- 0 – 10 A through 0 – 50 A Use

Sensor model No.: CLSB-05

Applicable cable diameter: Max. 10.0

Weight: 45 g (1.6 oz)

- 0 – 60 A through 0 – 100 A Use

Sensor model No.: CLSB-10

Applicable cable diameter: Max. 16.0

Weight: 80 g (2.8 oz)

- 0 – 125 A through 0 – 200 A Use

Sensor model No.: CLSB-20

Applicable cable diameter: Max. 24.0

Weight: 200 g (7.1 oz)

- 0 – 225 A through 0 – 400 A Use

Sensor model No.: CLSB-40

Applicable cable diameter: Max. 35.0

Weight: 300 g (10.6 oz)

- 0 – 500 A through 0 – 600 A Use

Sensor model No.: CLSB-60

Applicable cable diameter: Max. 35.0

Weight: 360 g (12.7 oz)

Note 1: The output values may vary depending on the accuracy of engagement at the clamp connection.

Note 2: The sensor is detachable up to 100 times (approx.).

Note 3: The sensor's mechanical construction may cause it

to generate resonance sound. However, it does not affect the performance of the sensor.

GENERAL SPECIFICATIONS

Construction: Terminal block

Connection: M3.5 screw terminals (torque 0.8 N·m)

Screw terminal: Nickel-plated steel

Housing material: Flame-resistant resin (black)

Isolation: Sensor core to input or output to power

Input waveform

RMS sensing: Up to 15 % of 3rd harmonic content

Zero adjustment: -2 to +2 % (front)

Span adjustment: 98 to 102 % (front)

Power LED: Green light turns on when the power is supplied.

INPUT SPECIFICATIONS

Frequency: 50 / 60 Hz

Overload capacity

CLSA - 08: 120 A continuous

CLSA - 12: 300 A continuous

CLSA - 30: 360 A continuous

CLSA - 50: 600 A continuous

CLSB - 05: 100 A continuous

CLSB - 10: 200 A continuous

CLSB - 20: 300 A continuous

CLSB - 40: 600 A continuous

CLSB - 60: 720 A continuous

Operational range: 5 – 120 % of rating

Be sure that the input voltage is of 440 V or less.

OUTPUT SPECIFICATIONS

■ **DC Current:** 0 – 20 mA DC

Minimum span: 1 mA

Offset: Max. 1.5 times span

Load resistance: Output drive 11 V max.

■ **DC Voltage:** 0 – 10 V DC

Minimum span: 1 V

Offset: Max. 1.5 times span

Load resistance: Output drive 10 mA max.; at ≥ 1 V

INSTALLATION

Power Consumption

• **AC:**

Approx. 2 VA at 100 V

Approx. 3 VA at 200 V

Approx. 3 VA at 264 V

• **DC:** Approx. 2 W

Operating temperature: -5 to +55°C (23 to 131°F)

Operating humidity: 0 to 90 %RH (non-condensing)

Mounting: DIN rail

Weight: 80 g (2.8 oz)

PERFORMANCE in percentage of span

Accuracy: $\pm 0.5\%$ with input 5 - 100 %

(Input 10 - 100 % for the output codes 4W and 5W)

Temp. coefficient: $\pm 0.015\%/^{\circ}\text{C}$ ($\pm 0.008\%/^{\circ}\text{F}$)

Response time: ≤ 0.5 sec. (0 - 90 %)

Ripple: 0.5 %p-p max.

Line voltage effect: $\pm 0.1\%$ over voltage range

Insulation resistance: $\geq 100\ \text{M}\Omega$ with 500 V DC

Dielectric strength

DC powered:

2000 V AC @1 minute (input or output to power to ground)

1000 V AC @1 minute (sensor core to sensor output)

AC powered:

1500 V AC @1 minute (input or output to power to ground)

1000 V AC @1 minute (sensor core to sensor output)

FRONT VIEW

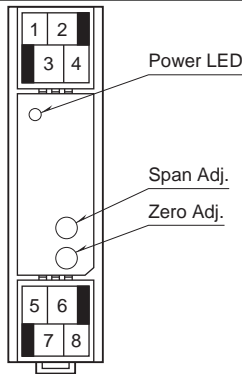

DIMENSIONS unit: mm (inch)

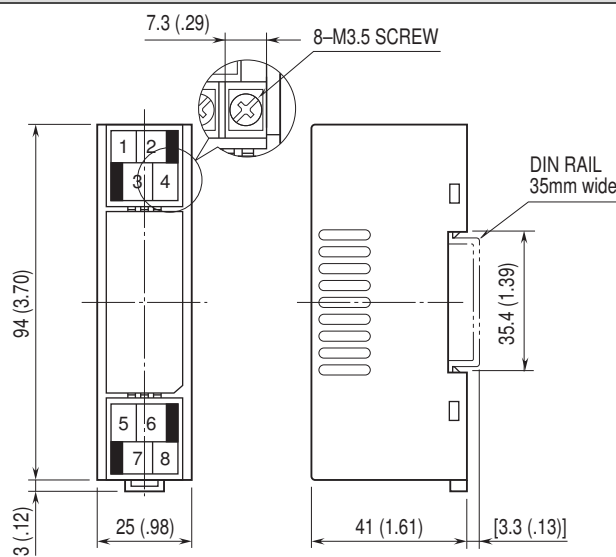

• When mounting, no extra space is needed between units.

■ Sensor model No.: CLSA-08

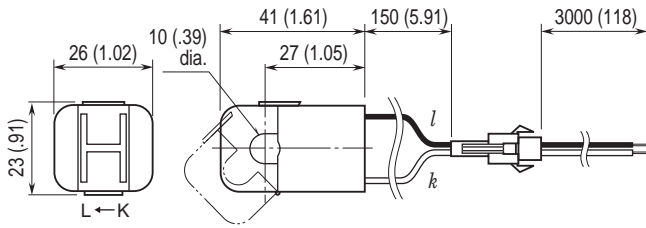

■ Sensor model No.: CLSA-12

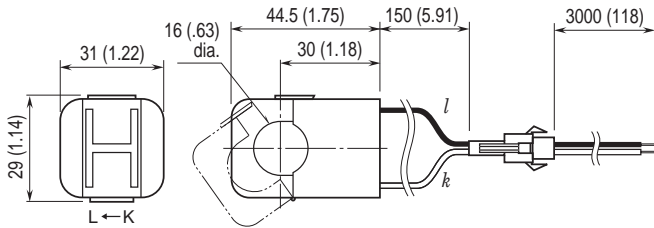

■ Sensor model No.: CLSA-30

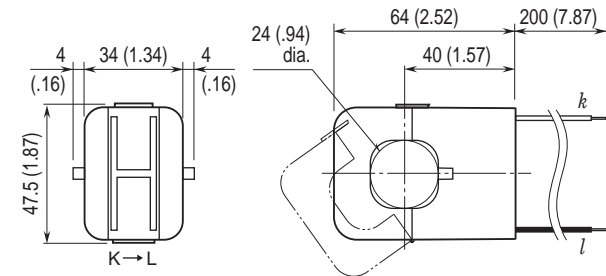

■ Sensor model No.: CLSA-50

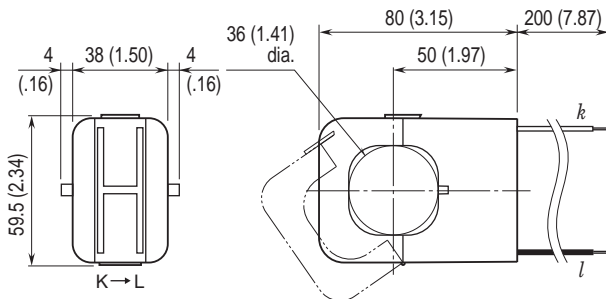

■ Sensor model No.: CLSB-05

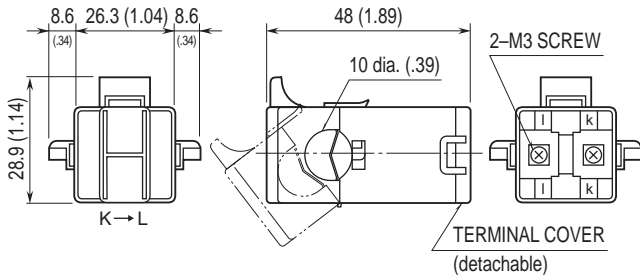

■ Sensor model No.: CLSB-10

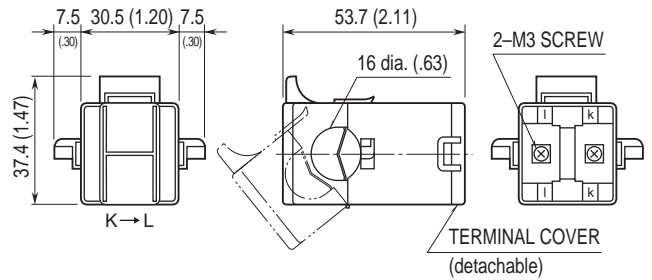

■ Sensor model No.: CLSB-20

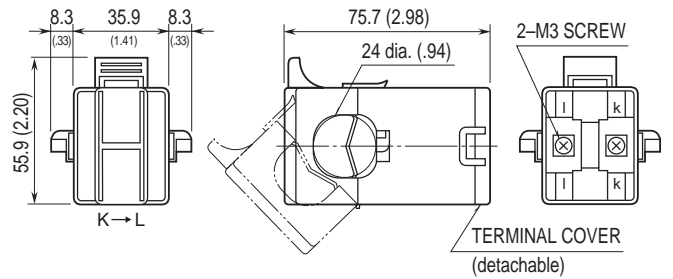

■ Sensor model No.: CLSB-40

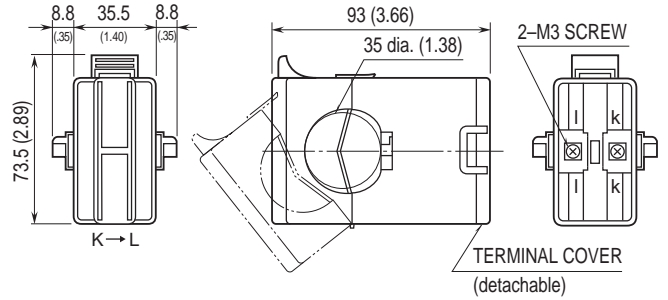

■ Sensor model No.: CLSB-60

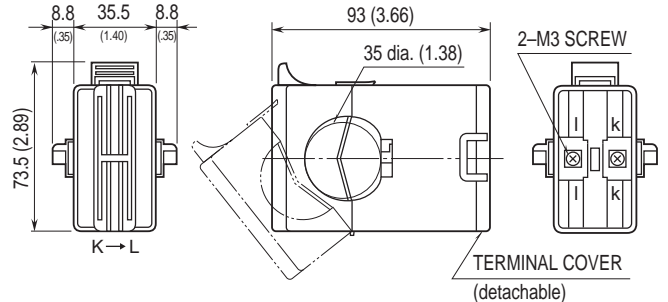

SCHEMATIC CIRCUITRY & CONNECTION DIAGRAM

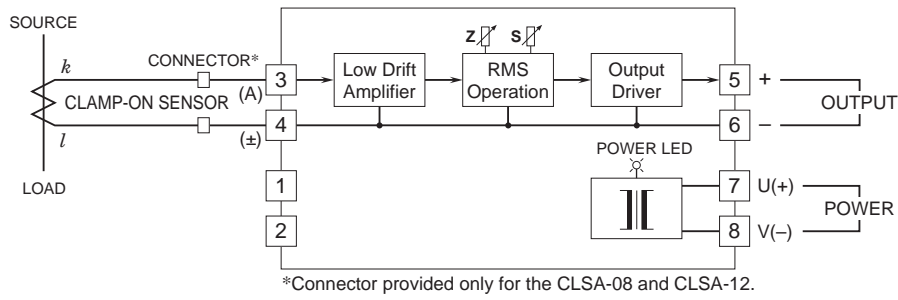

Specifications are subject to change without notice.