

## Super-mini Signal Conditioners Mini-M Series

### UNIVERSAL TRANSMITTER

(PC programmable)

#### Functions & Features

- Accepts direct inputs from various sensors and provides a standard process signal
- I/O types and calibration ranges are fully programmable via a PC
- Linearization up to 100 points can be programmed for DC and potentiometer inputs
- Isolation between input - output - power
- CE marking
- UL approval

#### Typical Applications

- Signal conversion between control room and field instrumentation with isolation
- Ideal for use as a fast solution, multifunctional spare part

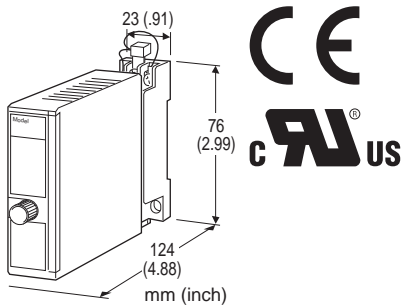

### MODEL: M2XU-[1][2]-[3][4]

#### ORDERING INFORMATION

- Code number: M2XU-[1][2]-[3][4]
- Specify a code from below for each [1] through [4]. (e.g. M2XU-00-R/CE/Q)
- Specify the specification for option code /Q (e.g. /C01/S01)

Non-specified orders will be shipped at default factory settings (M2XU-00: 4 - 20 mA input/4 - 20 mA output). However, the power suffix code **must** be specified. If you specify full code numbers without specific calibration ranges, default settings will be used.

#### [1] INPUT

**0:** User-calibrated (Factory default: 4 - 20 mA DC)  
If the unit is to be factory-calibrated to a specific input type, please select from the following:

##### Current

**Z1:** Range 0 - 50 mA DC (Input resistance 100 Ω)

##### Voltage

**S1:** Range -1 - +1 V DC (Input resistance 1 MΩ min.)

**S2:** Range -10 - +10 V DC (Input resistance 1 MΩ min.)

##### Thermocouple

**T1:** (PR) (Usable Range 0 to 1760°C, 32 to 3200°F)

**T2:** K (CA) (Usable range -270 to +1370°C, -454 to +2498°F)

**T3:** E (CRC) (Usable range -270 to +1000°C, -454 to +1832°F)

**T4:** J (IC) (Usable range -210 to +1200°C, -346 to +2192°F)

**T5:** T (CC) (Usable range -270 to +400°C, -454 to +752°F)

**T6:** B (RH) (Usable range 0 to 1820°C, 32 to 3308°F)

**T7:** R (Usable range -50 to +1760°C, -58 to +3200°F)

**T8:** S (Usable range -50 to +1760°C, -58 to +3200°F)

**T9:** C(WRe 5-26) (Usable range 0 to 2315°C, 32 to 4199°F)

**TN:** N (Usable range -270 to +1300°C, -454 to +2372°F)

**TU:** U (Usable range -200 to +400°C, -328 to +752°F)

**TL:** L (Usable range -200 to +900°C, -328 to +1652°F)

**TP:** Platine II (Usable range 0 to 1395°C, 32 to 2543°F)

**T0:** Specify (Please provide an emf table.)

##### RTD

**(2- or 3-wire)**

**R1:** JPt 100 (JIS'89)

(Usable range: -200 to +500°C, -328 to +932°F)

**R3:** Pt 100 (JIS'89)

(Usable range: -200 to +850°C, -328 to +1562°F)

**R4:** Pt 100 (JIS'97, IEC)

(Usable range: -200 to +850°C, -328 to +1562°F)

**R5:** Pt 50 Ω (JIS'81)

(Usable range: -200 to +649 °C, -328 to +1200°F)

**R6:** Ni 508.4 Ω

(Usable range: -50 to +200°C, -58 to +392°F)

**R7:** Pt 1000

(Usable range: -200 to +200°C, -328 to +392°F)

**R8:** Ni 100 (100 Ω @ 0°C)

(Usable range: -50 to +200°C, -58 to +392°F)

**R9:** Cu 10 (10 Ω @25°C)

(Usable range: -50 to +200°C, -58 to +392°F)

**R0:** Specify (Please provide a resistance table.)

##### Potentiometer

**M:** Total resistance 100 Ω - 10 kΩ

#### [2] OUTPUT

**0:** User-calibrated (Factory default: 4 - 20 mA DC)

If the unit is to be factory-calibrated to a specific output type, please select from the following:

##### Current

**Z1:** Range 0 - 20 mA DC

##### Voltage

**V1:** Range -2.5 - +2.5 V DC

**V2:** Range -10 - +10 V DC

**[3] POWER INPUT****AC Power**

**M2:** 100 – 240 V AC (Operational voltage range 85 – 264 V, 47 – 66 Hz)  
(90 – 264 V for UL)

**DC Power**

**R:** 24 V DC  
(Operational voltage range 24 V  $\pm$ 10 %, ripple 10 %p-p max.)  
**P:** 110 V DC  
(Operational voltage range 85 – 150 V, ripple 10 %p-p max.)  
(110 V  $\pm$ 10 % for UL)

**[4] OPTIONS (multiple selections)****STANDARDS & APPROVALS (must be specified)**

**/N:** Without CE or UL

**/CE:** CE marking

**/UL:** UL approval (CE marking)

**OTHER OPTIONS**

**blank:** none

**/Q:** Option other than the above (specify the specification)  
(UL not available)

**SPECIFICATIONS OF OPTION: Q (multiple selections)****COATING (For the detail, refer to M-System's web site.)**

**/C01:** Silicone coating

**/C02:** Polyurethane coating

**/C03:** Rubber coating

**TERMINAL SCREW MATERIAL**

**/S01:** Stainless steel

**RELATED PRODUCTS**

- JX configurator connection kit (model: JXCON)

**GENERAL SPECIFICATIONS**

**Construction:** Plug-in

**Connection:** M3 screw terminals (torque 0.8 N·m)

**Housing material:** Flame-resistant resin (black)

**Isolation:** Input to output to power

**Overrange output:** Approx. -15 to +115 %  
(Negative current output is not provided.)

**Manual zero adjustments:** -5 to +5 %  
(factory setting: 0 %)

**Manual span adjustments:** 95 to 105 %  
(factory setting: 100 %)

**Programming:** PC programmable features include:

- T/C and RTD type and temp. range
- Input and output ranges
- Zero and span adjustments
- Simulated output
- User's linearization table (max. 100 points, specified within

-15 – +115 % for both input and output)

• User's TC/RTD table

**Burnout (T/C, RTD and Pot.):** Upscale standard; downscale or no burnout options are PC programmable

**Linearization (T/C, RTD input):** Standard tables stored in memory

**Cold junction compensation (T/C):** CJC sensor (included) to be attached to the input terminals

**Status indicator LED:** Flashing patterns indicate different operating status of the transmitter.

**Configurator connection:** 2.5 dia. miniature jack; RS-232C level

**INPUT SPECIFICATIONS**

• **DC Current:** Shunt resistor attached to the input terminals (0.5 W)

**Operational range:** 0 – 70 mA DC with 100  $\Omega$ , 0.5 W

**Input range:** 0 – 50 mA DC

**Minimum span:** 2 mA

**Offset:** Lower range can be any specific value within the input range provided that the minimum span is maintained. If not specified, the input range is 4 – 20 mA DC.

• **DC Voltage**

**Operational range:** -11.5 – +11.5 V DC

**Input range:** -10 – +10 V DC

**Minimum span:** 10 mV for S1; 100 mV for S2

**Offset:** Lower range can be any specific value within the input range provided that the minimum span is maintained. If not specified, the input range is shown below.

S1: 0 – 100 mV DC

S2: 1 – 5 V DC

• **THERMOCOUPLE**

For T/C types K, E, T, B, R, S or N, the accuracy in the temperature ranges near the lower limit may be out of the described value. Consult M-System for more detail.

**Input resistance:** 1 M $\Omega$  min.

**Burnout sensing:** 45 nA  $\pm$ 10 %

**Offset:** Lower range can be any specific value within the input range provided that the minimum span is maintained. If not specified, the input range is shown below.

T1 PR : 0 – 1600°C

T2 K : 0 – 1000°C

T3 E : 0 – 500°C

T4 J : 0 – 500°C

T5 T : 0 – 300°C

T6 B : 0 – 1800°C

T7 R : 0 – 1600°C

T8 S : 0 – 1600°C

T9 C (WRe 5 - 26) : 0 – 2000°C

TN N : 0 – 1000°C

TU U : 0 – 300°C

TL L : 0 – 500°C

TP Platinel II : 0 - 1200°C

- **RTD:** 2- or 3-wire RTD

**Maximum leadwire resistance:** 200 Ω per wire (3 -wire)

**Sensing current:** ≤ 1.0 mA

If not specified, the input range is shown below.

R1: JPt 100 0 - 100°C

R3: Pt 100 0 - 100°C

R4: Pt 100 0 - 100°C

R5: Pt 50 Ω 0 - 200°C

R6: Ni 508.4 Ω 0 - 100°C

R7: Pt 1000 0 - 100°C

R8: Ni 100 0 - 100°C

R9: Cu 10 0 - 100°C

- **POTENTIOMETER:** 100 Ω - 10 kΩ

**Minimum span:**

(Range) 0 - 100 Ω : 2.5 Ω

0 - 300 Ω : 3.0 Ω

0 - 1000 Ω : 10 Ω

0 - 10 kΩ : 10 Ω

**Excitation:** ≤ 0.5 V DC at 1000 Ω

If not specified, the input range is 0 - 1000 Ω.

## OUTPUT SPECIFICATIONS

- **DC Current**

**Operational range:** 0 - 24 mA DC

**Output range:** 0 - 20 mA DC

**Minimum span:** 1 mA

**Offset:** Lower range can be any specific value within the output range provided that the minimum span is maintained.

**Load resistance:** Output drive 15 V max.

(e.g. 4 - 20 mA: 750 Ω [15 V / 20 mA])

If not specified, the output range is 4 - 20 mA DC.

- **DC VOLTAGE**

**Code V1 (narrow spans)**

**Operational range:** -3 - +3 V DC

**Output range:** -2.5 - +2.5 V DC

**Minimum span:** 250 mV

**Code V2 (wide spans)**

**Operational range:** -11.5 - +11.5 V DC

**Output range:** -10 - +10 V DC

**Minimum span:** 1 V

**Offset:** Lower range can be any specific value within the output range provided that the minimum span is maintained.

**Load resistance:** Output drive 1 mA max.

(e.g. 1 - 5 V: 5000 Ω [5 V / 1 mA])

If not specified, the output range is shown below.

V1: 0 - 1 V DC

V2: 1 - 5 V DC

## INSTALLATION

**Power Consumption**

• **AC Power input:** Approx. 6 VA

• **DC Power input:** Approx. 3 W

**Operating temperature:** -30 to +60°C (-22 to +140°F)

**Operating humidity:** 30 to 90 %RH (non-condensing)

**Mounting:** Surface or DIN rail

**Weight:** 120 g (0.26 lbs)

## PERFORMANCE

**Accuracy:** Input accuracy + output accuracy

**Input accuracy** (% of input range)

Inversely proportional to span.

(DC) -1 - +1 V : ±0.02

-10 - +10 V : ±0.02

0 - 50 mA : ±0.02

Except the input resistor error.

(T/C) (PR) : ±0.08

K (CA) : ±0.02

E (CRC) : ±0.02

J (IC) : ±0.04

T (CC) : ±0.06

B (RH) : ±0.12

R : ±0.08

S : ±0.08

C (WRe 5 - 26) : ±0.04

N : ±0.04

U : ±0.04

L : ±0.04

P (Platinel II) : ±0.04

(RTD) JPt 100 (JIS '89) : ±0.04

Pt 100 (JIS '89) : ±0.03

Pt 100 (JIS '97, IEC) : ±0.03

Pt 50 Ω (JIS '81) : ±0.04

Ni 508.4 Ω : ±0.05

Pt 1000 : ±0.08

Ni 100 : ±0.14

Cu 10 : ±0.6

(Pot.) 0 - 100 Ω : ±0.08

0 - 300 Ω : ±0.04

0 - 1000 Ω : ±0.04

0 - 10 kΩ : ±0.04

**Output accuracy:** ±0.02 % of output range

Inversely proportional to span.

**Cold junction compensation error:**

±0.4°C or ±0.7°F (at 20°C ±10°C or 68°F ±18°F)

**Temp. coefficient**

(at -5 to +55°C [23 to 131°F] of I/O range)

**Input:** ±0.016 %/°C (±0.009 %/°F) with current

±0.004 %/°C (±0.002 %/°F) with voltage

±0.004 %/°C (±0.002 %/°F) with T/C

±0.004 %/°C (±0.002 %/°F) with RTD

±0.004 %/°C (±0.002 %/°F) with Pot.

**Output:** ±0.013 %/°C (±0.007 %/°F)

**Response time:**

≤ 0.5 sec.(0 - 90 %) with current

≤ 0.5 sec.(0 - 90 %) with voltage

≤ 1.5 sec.(0 - 90 %) with T/C

≤ 0.9 sec.(0 - 90 %) with RTD

≤ 0.9 sec. (0 - 90 %) with Pot.

**Burnout response:** ≤ 10 sec.

**Line voltage effect:** ±0.1 % over voltage range

**Insulation resistance:** ≥ 100 MΩ with 500 V DC

**Dielectric strength:** 2000 V AC @1 minute (input to output to power to ground)

## CALCULATION EXAMPLES OF OVERALL ACCURACY

[Example] Input Type -10 - +10 V, Input Range 1 - 5 V,

Output Type 0 - 20 mA, Output Range 0 - 10 mA

Max. Input Range (20 V) / Span (4 V) × 0.02 % = 0.1 %

Max. Output Range (20 mA) / Span (10 mA) × 0.02 % = 0.04 %

Overall accuracy = 0.1 + 0.04 = ±0.14 %

## STANDARDS & APPROVALS

**CE conformity:**

EMC Directive (2004/108/EC)

EN 61000-6-4 (EMI)

EN 61000-6-2 (EMS)

Low Voltage Directive (2006/95/EC)

EN 61010-1

Installation Category II

Pollution Degree 2

Max. operating voltage 300 V

Input or output to power: Reinforced insulation

Input to output: Basic insulation

**Approval:**

UL/C-UL nonincendive Class I, Division 2,

Groups A, B, C, and D hazardous locations

(UL 1604, CAN/CSA-C22.2 No.213)

UL/C-UL general safety requirements

(UL 61010B-1, CAN/CSA-C22.2 No.1010-1)

## EXTERNAL VIEW

### FRONT VIEW (with cover open)

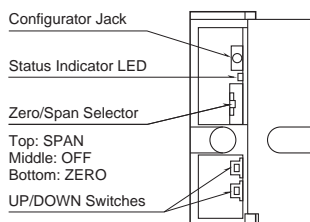

The front cover cannot be opened to 180 deg. when flush with neighboring units.

### RIGHT SIDE VIEW

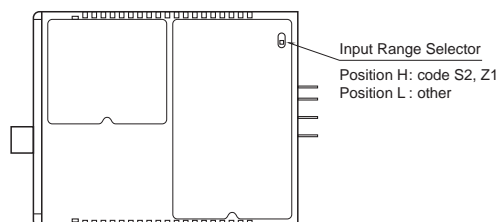

Refer to the instruction manual for detailed procedures.

## DIMENSIONS unit: mm (inch)

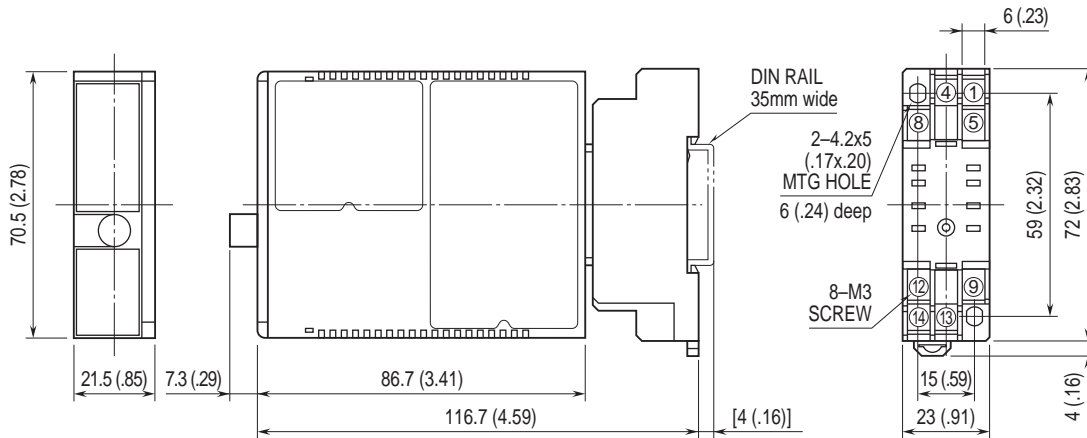

• When mounting, no extra space is needed between units.

## TERMINAL ASSIGNMENTS unit: mm (inch)

Use the input resistor (model: REM2) for a DC current input, and the CJC sensor (model: CJM) for a thermocouple input, both included in the package.

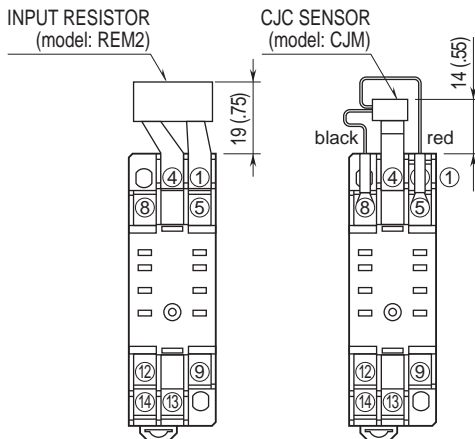

## SCHEMATIC CIRCUITRY & CONNECTION DIAGRAM

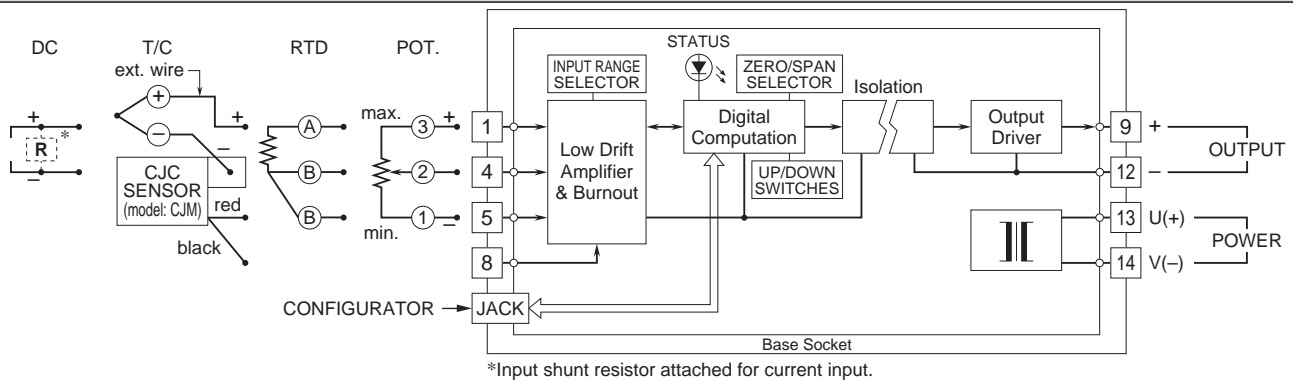



Specifications are subject to change without notice.