

Super-mini Signal Conditioners Mini-M Series

THERMOCOUPLE TRANSMITTER

(PC programmable)

Functions & Features

- Accepts direct input from a thermocouple and provides a linearized process signal
- PC programmable
- Wide selection of thermocouples
- User's temperature table can be used
- Leadwire resistance compensation
- CE marking
- UL approval

Typical Applications

- Small burnout sensing current enables long distance transmission with minimum offset drifts
- Electric furnace (isolation ensured even when 200 V AC power for heater leaks through furnace wall)
- No burnout type can connect to a single T/C in parallel with a recorder
- Ideal for quick spare part

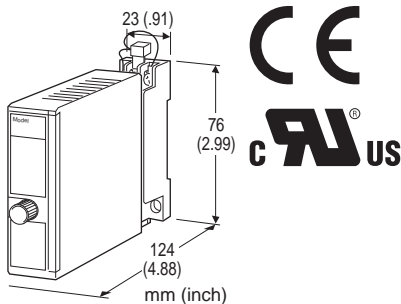

MODEL: M2XT2-[1][2]-[3][4]

ORDERING INFORMATION

- Code number: M2XT2-[1][2]-[3][4]
- Specify a code from below for each [1] through [4].
(e.g. M2XT2-2Z1-M2/BL/CE/Q)
- K thermocouple setting will be used if the input code is not specified.
- Temperature range (e.g. 0 - 800°C)
 - Output range (e.g. 4 - 20 mA DC)
 - Specify the specification for option code /Q (e.g. /C01/S01)

[1] INPUT THERMOCOUPLE

- 1: (PR)
- 2: K (CA)

- 3: E (CRC)
 - 4: J (IC)
 - 5: T (CC)
 - 6: B (RH)
 - 7: R
 - 8: S
 - 9: C (WRe 5-26)
 - N: N
 - U: U
 - L: L
 - P: Platinel II
 - 0: Specify
- (Configurator software is used to change the input type and precise range.)

[2] OUTPUT

Current

Z1: Range 0 - 20 mA DC

Voltage

V1: Range -2.5 - +2.5 V DC

V2: Range -10 - +10 V DC

(Configurator software is used to change output over the described range of the selected suffix code. For changing out of this range, set the Output Range Selectors inside the unit before software adjustment.)

[3] POWER INPUT

AC Power

M2: 100 - 240 V AC (Operational voltage range 85 - 264 V, 47 - 66 Hz)
(90 - 264 V for UL)

DC Power

R: 24 V DC
(Operational voltage range 24 V \pm 10 %, ripple 10 %p-p max.)
P: 110 V DC
(Operational voltage range 85 - 150 V, ripple 10 %p-p max.)
(110 V \pm 10 % for UL)

[4] OPTIONS (multiple selections)

Burnout

blank: Upscale burnout
/BL: Downscale burnout
(UL not available)
/BN: No burnout
(UL not available)

Standards & Approvals (must be specified)

/N: Without CE or UL
/CE: CE marking
/UL: UL approval, CE marking

Other Options

blank: none

/Q: Option other than the above (specify the specification)
(UL not available)

U U: 0–300°C
L L: 0–500°C
P Platinel II: 0–1200°C

SPECIFICATIONS OF OPTION: Q (multiple selections)

COATING (For the detail, refer to M-System's web site.)

/C01: Silicone coating
/C02: Polyurethane coating
/C03: Rubber coating

TERMINAL SCREW MATERIAL

/S01: Stainless steel

RELATED PRODUCTS

- JX configurator connection kit (model: JXCON)

GENERAL SPECIFICATIONS

Construction: Plug-in

Connection: M3 screw terminals (torque 0.8 N·m)

Housing material: Flame-resistant resin (black)

Isolation: Input to output to power

Overrange output: Approx. -15 to +115 %
(Negative current output is not provided.)

Manual zero/span adjustments: See Front View.

Programming: Downloaded from PC; T/C type, temp. range, output range, zero and span, simulating output, etc.

Burnout protection: Upscale standard; downscale or no burnout optional by programming
(Set to "no burnout" when the unit is connected with another instrument in parallel.)

Linearization: Standard

Cold junction compensation: CJC sensor attached to the input terminals

Status indicator LED: Flashing patterns indicate different operating status of the transmitter.

Configurator connection: 2.5 dia. miniature jack;
RS-232-C level

INPUT SPECIFICATIONS

Input resistance: 1 MΩ min.

Burnout sensing: 45 nA ±10 %

If not specified, the input range is shown below.

1 PR: 0–1600°C
2 K: 0–1000°C
3 E: 0–500°C
4 J: 0–500°C
5 T: 0–300°C
6 B: 0–1800°C
7 R: 0–1600°C
8 S: 0–1600°C
9 C (WRe 5-26): 0–2000°C
N N: 0–1000°C

OUTPUT SPECIFICATIONS

■ **DC Current**

Operational range: 0 – 24 mA DC

Output range: 0 – 20 mA DC

Minimum span: 1 mA

Offset: Lower range can be any specific value within the output range provided that the minimum span is maintained.

Load resistance: Output drive 15 V max.

(e.g. 4 – 20 mA: 750 Ω [15 V / 20 mA])

If not specified, the output range is 4 – 20 mA DC.

■ **DC Voltage**

Code V1 (narrow spans)

Operational range: -3 – +3 V DC

Output range: -2.5 – +2.5 V DC

Minimum span: 250 mV

Code V2 (wide spans)

Operational range: -11.5 – +11.5 V DC

Output range: -10 – +10 V DC

Minimum span: 1 V

Offset: Lower range can be any specific value within the output range provided that the minimum span is maintained.

Load resistance: Output drive 1 mA max.

(e.g. 1 – 5 V: 5000 Ω [5 V / 1 mA])

If not specified, the output range is shown below.

V1: 0 – 1 V DC

V2: 1 – 5 V DC

INSTALLATION

Power Consumption

• **AC:**

Approx. 3 VA at 100 V

Approx. 4 VA at 200 V

Approx. 5 VA at 264 V

• **DC:** Approx. 2 W

Operating temperature: -30 to +60°C (-22 to +140°F)

Operating humidity: 30 to 90 %RH (non-condensing)

Mounting: Surface or DIN rail

Weight: 120 g (0.26 lbs)

PERFORMANCE

Accuracy: [Table 1 Accuracy value + Cold Junction

Compensation Error 0.5°C (0.9°F)] or ±0.1 % of span, whichever is greater.

Add 0.2 % when the output span equals 1/10 or narrower of the max. span.

Cold junction compensation error:

±0.5°C at 25 ±10°C

±0.9°F at 77 ±18°F

Temp. coefficient: ±0.015 %/°C (±0.008 %/°F) of max. span at -5 to +55°C [23 to 131°F]

Response time: ≤ 0.9 sec. (0 - 90 %)

Burnout response: ≤ 10 sec.

Line voltage effect: ±0.1 % over voltage range

Insulation resistance: ≥ 100 MΩ with 500 V DC

Dielectric strength: 2000 V AC @1 minute (input to output to power to ground)

CALCULATION EXAMPLES OF OVERALL ACCURACY

[Example 1]

Input: K thermocouple, 0 - 1000°C, Output: 4 - 20 mA DC

1) Absolute value accuracy (Table 1): 0.25°C

2) CJC error (0.5°C) added: 0.75°C

3) $0.75^\circ\text{C} / 1000^\circ\text{C} \times 100 = 0.075 \%$

4) $0.075 \% < 0.1 \%$ of span. ➔ 0.1 % is selected.

5) Output span 16 mA (= 20 mA - 4 mA)

Max. span 20 mA

Output span ≥ 1/10 of max. span ➔ No need of adding 0.2 %.

6) Overall accuracy equals ±0.1 % of span

[Example 2]

Input: K thermocouple, 50 - 150°C, Output: 2.0 - 2.5 V DC

1) Absolute value accuracy (Table 1): 0.25°C

2) CJC error (0.5°C) added: 0.75°C

3) $0.75^\circ\text{C} / (150 - 50)^\circ\text{C} \times 100 = 0.75 \%$

4) $0.75 \% > 0.1 \%$ of span. ➔ 0.75 % is selected.

5) Output span 0.5 V (= 2.5 V - 2.0 V)

Max. span 5 V

Output span ≤ 1/10 of max. span ➔ Add 0.2 %.

6) Overall accuracy equals ±0.95 % of span (0.75 + 0.2)

Table 1.

THERMO-COUPLE	°C			
	MIN. SPAN	MAXIMUM RANGE	ACCURACY	CONFORMANCE RANGE
(PR)	20	0 to 1760	±1.00	0 to 1760
K (CA)	20	-270 to +1370	±0.25	-150 to +1370
E (CRC)	20	-270 to +1000	±0.20	-170 to +1000
J (IC)	20	-210 to +1200	±0.25	-180 to +1200
T (CC)	20	-270 to +400	±0.25	-170 to +400
B (RH)	20	0 to 1820	±0.75	400 to 1760
R	20	-50 to +1760	±0.50	200 to 1760
S	20	-50 to +1760	±0.50	0 to 1760
C (WRe 5-26)	20	0 to 2315	±0.80	0 to 2315
N	20	-270 to +1300	±0.30	-130 to +1300
U	20	-200 to +600	±0.20	-200 to +600
L	20	-200 to +900	±0.25	-200 to +900
P (Platinel II)	20	0 to 1395	±0.25	0 to 1395
THERMO-COUPLE	°F			
	MIN. SPAN	MAXIMUM RANGE	ACCURACY	CONFORMANCE RANGE
(PR)	36	32 to 3200	±1.80	32 to 3200
K (CA)	36	-454 to +2498	±0.45	-238 to +2498
E (CRC)	36	-454 to +1832	±0.36	-274 to +1832
J (IC)	36	-346 to +2192	±0.45	-292 to +2192
T (CC)	36	-454 to +752	±0.45	-274 to +752
B (RH)	36	32 to 3308	±1.35	752 to 3200
R	36	-58 to +3200	±0.90	392 to 3200
S	36	-58 to +3200	±0.90	32 to 3200
C (WRe 5-26)	36	32 to 4199	±1.44	32 to 4199
N	36	-454 to +2372	±0.54	-202 to +2372
U	36	-328 to +1112	±0.36	-328 to +1112
L	36	-328 to +1652	±0.45	-328 to +1652
P (Platinel II)	36	32 to 2543	±0.45	32 to 2543

STANDARDS & APPROVALS

CE conformity:

EMC Directive (2004/108/EC)

EN 61000-6-4 (EMI)

EN 61000-6-2 (EMS)

Low Voltage Directive (2006/95/EC)

EN 61010-1

Installation Category II

Pollution Degree 2

Max. operating voltage 300 V

Input or output to power: Reinforced insulation

Input to output: Basic insulation

Approval:

UL/C-UL nonincendive Class I, Division 2,

Groups A, B, C, and D hazardous locations

(UL 1604, CAN/CSA-C22.2 No.213)

UL/C-UL general safety requirements

(UL 61010B-1, CAN/CSA-C22.2 No.1010-1)

EXTERNAL VIEW

FRONT VIEW (with cover open)

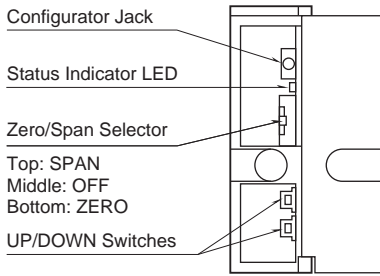

LEFT SIDE VIEW (with cover removed)

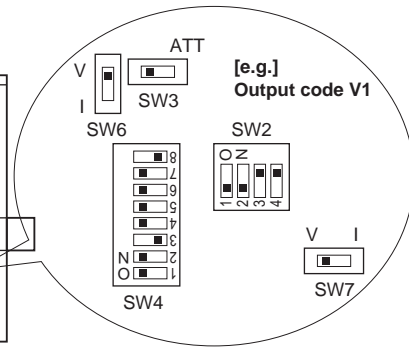
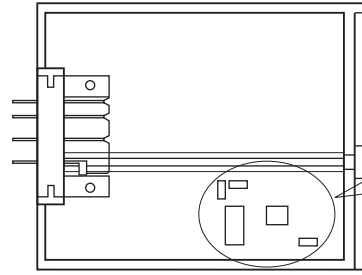

Output Range Selectors

The front cover cannot be turned open by 180 deg. when there is no extra space between units.

Refer to the instruction manual for detailed procedures.

DIMENSIONS unit: mm (inch)

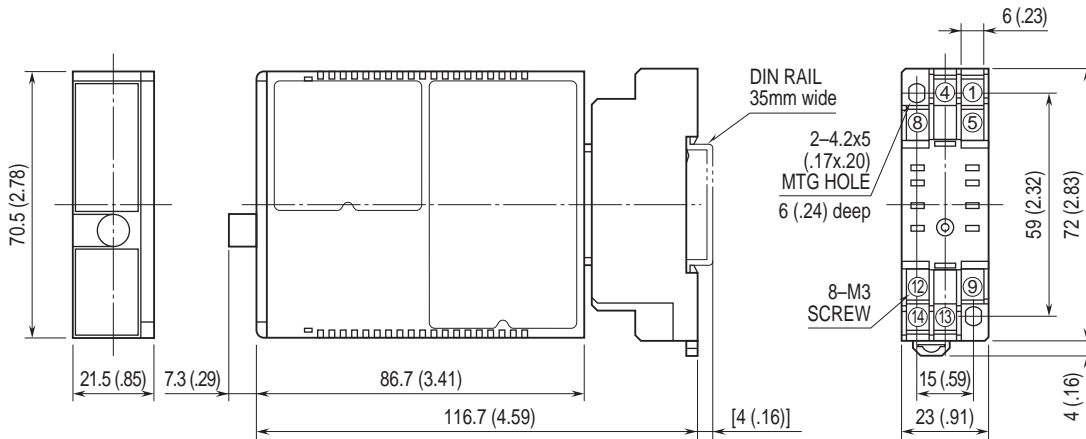

• When mounting, no extra space is needed between units.

TERMINAL ASSIGNMENTS unit: mm (inch)

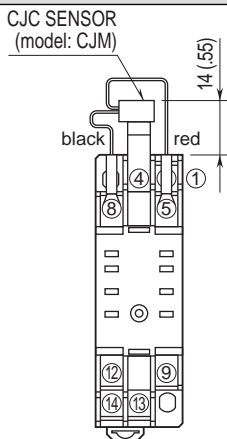

SCHEMATIC CIRCUITRY & CONNECTION DIAGRAM

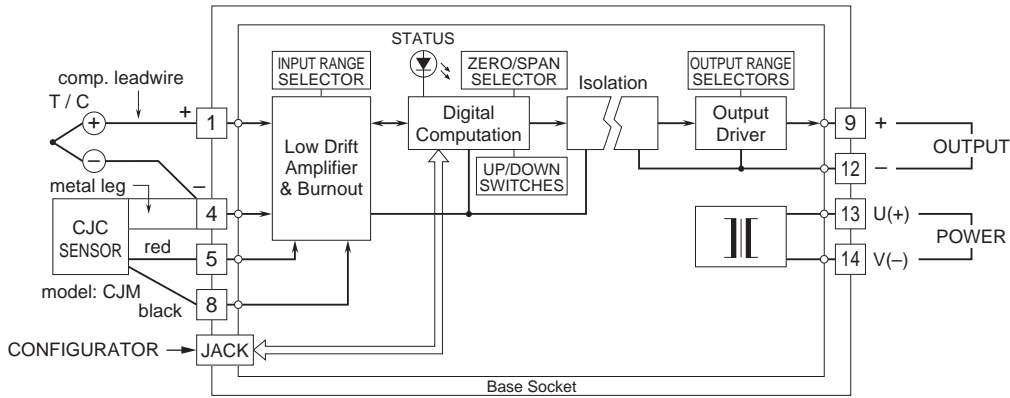

Specifications are subject to change without notice.