

Super-mini Signal Conditioners Mini-M Series

DISCONTINUED MODEL

Replaced with Model M2XPA3

FREQUENCY TRANSMITTER

(PC programmable)

Functions & Features

- Converts the output from a pulse-type transducer into a standard process signal
- PC programmable
- Sensor excitation
- Direct RS-422 input
- CE marking
- UL approval

Typical Applications

- Positive displacement flowmeters, turbine flowmeters and vortex flowmeters
- Measuring rotation speed of a machine generating dry contact signals

MODEL: M2XPA2-[1][2][3]-[4][5]

ORDERING INFORMATION

- Code number: M2XPA2-[1][2][3]-[4][5]

Specify a code from below for each [1] through [5].

- (e.g. M2XPA2-A14Z1-M2/CE/Q)
- Specify the specification for option code /Q (e.g. /C01/S01)
- Non-specified orders will be shipped at default factory settings (M2XPA2-000: Open collector input/12 V excitation/4- 20 mA output). However, a power suffix code must be specified.

If you specify a full code number without specific calibration ranges, the input frequency is factory set to the maximum range available for the selected input code and the output is set to the default range.

Use Ordering Information Sheet (No. ESU-5060).

[1] INPUT

0: User-calibrated (Factory default: open collector, 0 - 100 kHz)

If the unit is to be factory-calibrated to a specific input type, please select from the following:

- A1:** Open collector
- A2:** Mechanical contact
- B:** Voltage pulse
- G:** Two-wire current pulse
- J:** RS-422 line driver pulse

Configurator software is used to change the frequency range. The input type can be switched to other than the one of the selected suffix code by selecting the input type selectors inside the unit before software adjustment.

[2] EXCITATION

0: User-calibrated (Factory default: 12 V DC / 5 mA)

If the unit is to be factory-calibrated to a specific voltage value, please select from the following:

- 2:** 4 V DC / 5 mA
- 3:** 8 V DC / 5 mA
- 4:** 12 V DC / 5 mA

Configurator software is used to change the excitation value.

[3] OUTPUT

0: User-calibrated (Factory default: 4 - 20 mA)

If the unit is to be factory-calibrated to a specific output type, please select from the following:

Current

Z1: Range 0 - 20 mA DC

Voltage

V1: Range -2.5 - +2.5 V DC

V2: Range -10 - +10 V DC

(Configurator software is used to adjust the output range and to change the output over the described range of the selected suffix code.)

[4] POWER INPUT

AC Power

M2: 100 - 240 V AC (Operational voltage range 85 - 264 V, 47 - 66 Hz)
(90 - 264 V for UL)

DC Power

R: 24 V DC
(Operational voltage range 24 V \pm 10 %, ripple 10 %p-p max.)

P: 110 V DC
(Operational voltage range 85 - 150 V, ripple 10 %p-p max.)
(110 V \pm 10 % for UL)

[5] OPTIONS (multiple selections)

STANDARDS & APPROVALS (must be specified)

- /N:** Without CE or UL
- /CE:** CE marking
- /UL:** UL approval (CE marking)

OTHER OPTIONS

- blank:** none
- /Q:** Option other than the above (specify the specification)
(UL not available)

SPECIFICATIONS OF OPTION: Q (multiple selections)

COATING (For the detail, refer to M-System's web site.)

- /C01: Silicone coating
- /C02: Polyurethane coating
- /C03: Rubber coating

TERMINAL SCREW MATERIAL

- /S01: Stainless steel

RELATED PRODUCTS

- JX configurator connection kit (model: JXCON)

GENERAL SPECIFICATIONS

Construction: Plug-in

Connection: M3 screw terminals (torque 0.8 N·m)

Housing material: Flame-resistant resin (black)

Isolation: Input to output to power

Overrange output: Approx. -15 to +115 % at 1 - 5 V

Zero adjustment: -5 to +5 % (front)

Span adjustment: 95 to 105 % (front)

Configuration: Via PC Configurator Software (model: JXCON) on the Windows PC connected to the front jack.

Programmable features include: I/O type and range, Zero and span adjustments, Low-end cutout, etc.

DIP switch settings:

- Input Type
 - Pulse Sensing (Capacitor Coupled, DC Coupled)
 - Noise Filter
- Large (time constant 50 ms), Small (time constant 10 ms), Without

INPUT SPECIFICATIONS

Measurable frequencies: Minimum span 10 % of the frequency range selected among:

0 - 10 Hz, 0 - 100 Hz, 0 - 1 kHz, 0 - 10 kHz, 0 - 100 kHz

Pulse width time requirement: Min. 5 µsec., max. 10 sec.

• Open Collector

Maximum frequency: 0 - 100 kHz

Input amplitude: Min. 4 V, max. 12 V

Sensing voltage / current:

Approx. 12 V, 8 V or 4 V DC @1 mA

Detecting levels: ≤ 200 Ω for ON; ≥ 200 kΩ for OFF

If not specified, the input range is 0 - 100 kHz.

• Mechanical Contact

Maximum frequency: 0 - 10 Hz

Input amplitude: Min. 4 V, max. 12 V

Sensing voltage / current:

Approx. 12 V, 8 V or 4 V DC @1 mA

Detecting levels: ≤ 200 Ω for ON; ≥ 200 kΩ for OFF

If not specified, the input range is 0 - 10 Hz.

• Voltage Pulse

Maximum frequency: 0 - 100 kHz

Waveform: Square or sine

Input impedance: 10 kΩ min.

Input amplitude: Min. 0.1 Vp-p, max. 100 Vp-p

Maximum voltage between input terminals: See table 1.

Detecting levels: -2 - +4 V

If not specified, the input range is 0 - 100 kHz.

• Two-wire Current Pulse

Maximum frequency: 0 - 100 kHz

Input resistance: Receiving resistor 100 Ω

Input range: 0 - 25 mA

Input amplitude: Min. 4 mA, max. 20 mA

Detecting levels: -2 - +4 V

If not specified, the input range is 0 - 100 kHz.

• RS-422 LINE DRIVER PULSE

Maximum frequency: 0 - 100 kHz

Receiver: Conforms to RS-422

If not specified, the input range is 0 - 100 kHz.

[Table 1.(Voltage Pulse)]

AMPLITUDE	MAXIMUM VOLTAGE
50 - 100V p-p	100V *1
25 - 50V p-p	50V
10 - 25V p-p	25V
5 - 10V p-p	10V
1 - 5V p-p	5V
0.5 - 1V p-p	1V
0.1 - 0.5V p-p	0.5V *2

*1, Max. 70V for CE conformance or UL approval.

*2, Max. input frequency limited to 50 kHz.

OUTPUT SPECIFICATIONS

• **DC Current:**Operational range: 0 - 24 mA DC

Output range: 0 - 20 mA DC

Minimum span: 1 mA

Offset: Lower range can be any specific value within the output range provided that the minimum span is maintained.

Load resistance: Output drive 12 V max.

(e.g. 4 - 20 mA: 600 Ω [12 V / 20 mA])

If not specified, the output range is 4 - 20 mA DC.

• DC VOLTAGE

Code V1 (narrow spans)

Conformance range: -3 - +3 V DC

Output range: -2.5 - +2.5 V DC

Minimum span: 250 mV

Code V2 (wide spans)

Conformance range: -11.5 - +11.5 V DC

Output range: -10 - +10 V DC

Minimum span: 1 V

Offset: Lower range can be any specific value within the output range provided that the minimum span is maintained.

Load resistance: Output drive 1 mA max.

(e.g. 1 - 5 V: 5000 Ω [5 V / 1 mA])

If not specified, the output range is shown below.

V1: 0 - 1 V DC

V2: 1 - 5 V DC

INSTALLATION

Power Consumption

•AC Power input:

Approx. 4 VA at 100 V

Approx. 5 VA at 200 V

Approx. 6 VA at 264 V

•DC Power input: Approx. 3 W

Operating temperature: -5 to +55°C (23 to 131°F)

Operating humidity: 30 to 90 %RH (non-condensing)

Mounting: Surface or DIN rail

Weight: 150 g (0.33 lbs)

PERFORMANCE

Accuracy: Input accuracy + output accuracy

Inversely proportional to the span.

Input accuracy: ±0.03 % of the selected freq. range

Output accuracy: ±0.03 % of the selected output range

See CALCULATION EXAMPLES OF OVERALL ACCURACY.

Temp. coefficient: ±0.015 %/°C (±0.008 %/°F) of I/O range at -5 to +55°C [23 to 131°F]

Response time: Ts + Td (0 - 90 %)

Ts : Measuring Time = Sampling time x 4

Td : Delay = 300 msec.

[Example] Sampling time 50 msec. (standard setting)

Delay time 300 msec.

When the input cycle is shorter than the sampling time, the response time is calculated as:

50 msec. x 4 + 300 msec. = 500 msec.

When the input cycle is longer than the sampling time, the response time becomes longer accordingly.

Line voltage effect: ±0.1 % over voltage range

Insulation resistance: ≥ 100 MΩ with 500 V DC

Dielectric strength: 2000 V AC @1 minute (input to output to power to ground)

■RESPONSE TIME

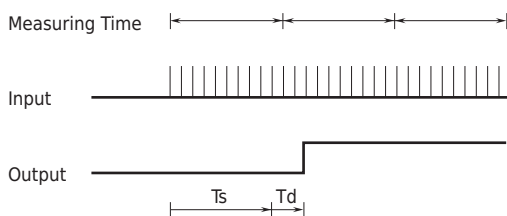

Ts : Measuring Time = Sampling time x 4

Td : Delay = 300 msec.

CALCULATION EXAMPLES OF OVERALL ACCURACY

[Example] Open collector input, 0 - 50 kHz; 1 - 5 V output.

Selected freq. range (100 kHz) / Input span (50 kHz) x

Accuracy (0.03 %) = 0.06 % (Input accuracy)

Selected output range (20 V) / Output span (4 V) x

Accuracy (0.03 %) = 0.15 % (Output accuracy)

Overall accuracy = 0.06 + 0.15 = ±0.21 %

STANDARDS & APPROVALS

CE conformity:

EMC Directive (2004/108/EC)

EN 61000-6-4 (EMI)

EN 61000-6-2 (EMS)

Low Voltage Directive (2006/95/EC)

EN 61010-1

Installation Category II

Pollution Degree 2

Max. operating voltage 300 V

Input or output to power: Reinforced insulation

Input to output: Basic insulation

Approval:

UL/C-UL nonincendive Class I, Division 2,

Groups A, B, C, and D hazardous locations

(ANSI/ISA-12.12.01, CAN/CSA-C22.2 No.213)

UL/C-UL general safety requirements

(UL 61010B-1, CAN/CSA-C22.2 No.1010-1)

EXTERNAL VIEW

FRONT VIEW (with cover open)

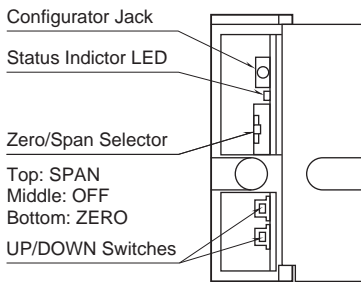

The front cover cannot be opened to 180 deg. when flush with neighboring units.

LEFT SIDE VIEW (with cover removed)

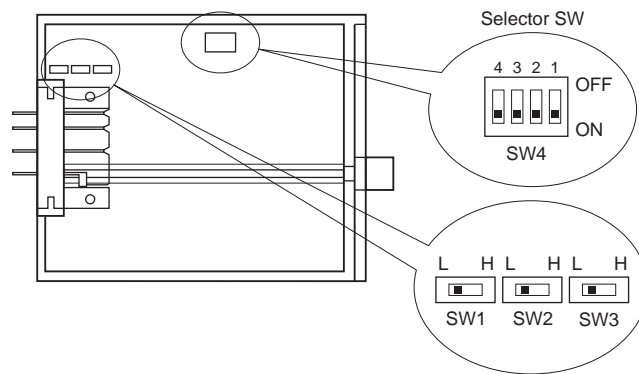

Refer to the instruction manual for detailed procedures.

DIMENSIONS unit: mm (inch)

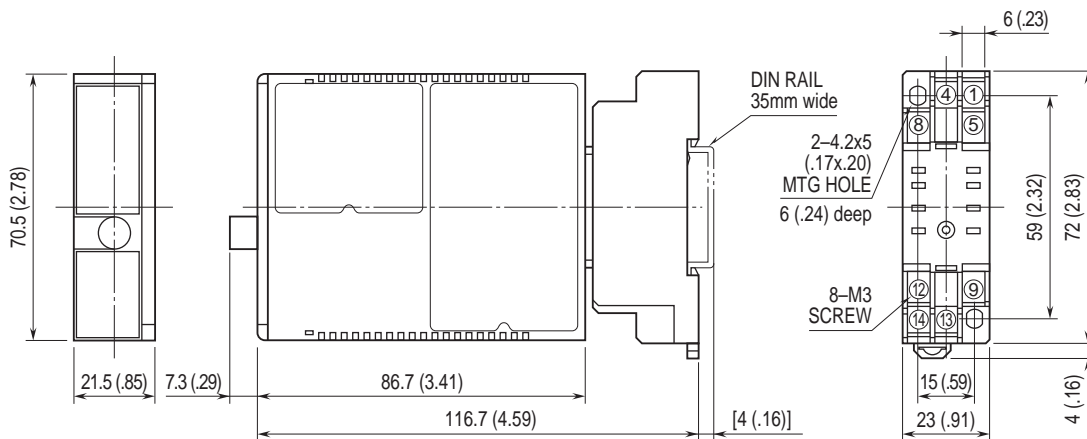

• When mounting, no extra space is needed between units.

SCHEMATIC CIRCUITRY & CONNECTION DIAGRAM

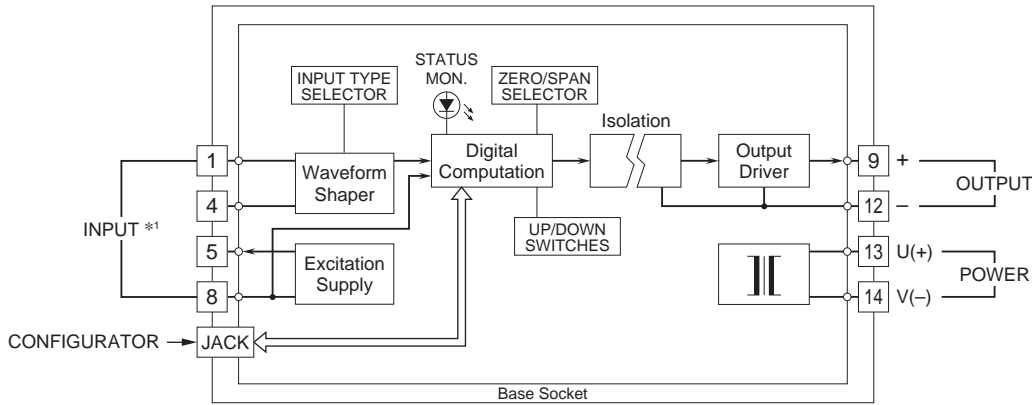

*1. Input Connection Examples

■ Dry Contact

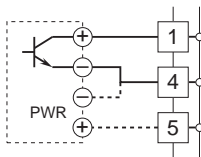

■ Voltage Pulse

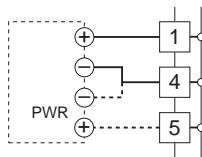

■ 2-Wire Current Pulse

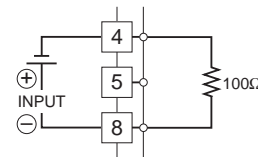

■ Mechanical Contact

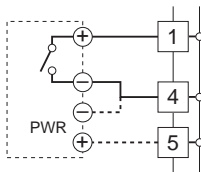

■ RS-422 Line Driver Pulse

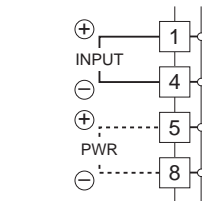

EXPLANATIONS OF TERMS

Low-end cutout:

The function where the output signal is forced to 0% below the setpoint input.

[Example] Input zero frequency 0 Hz

Input span frequency 1 kHz

Low-end cutout 10 %

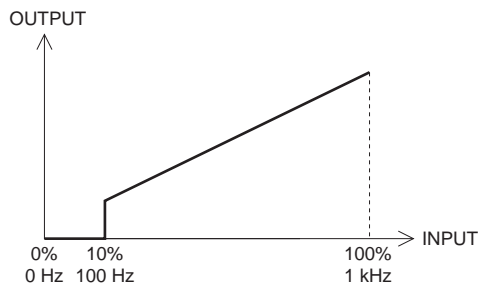

Specifications are subject to change without notice.