

Super-mini Signal Conditioners Mini-M Series

SUBTRACTOR

Functions & Features

- Receives two DC inputs and provides an output proportional to the subtraction of the inputs
- CE marking
- UL approval

Typical Applications

- Calculating temperature or flow differences

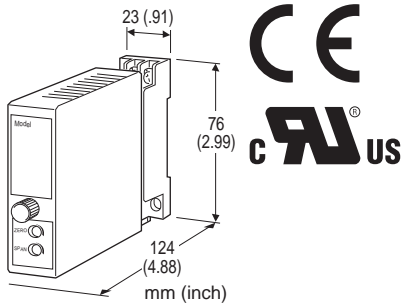

MODEL: M2SBS-[1][2][3]-[4][5]

ORDERING INFORMATION

- Code number: M2SBS-[1][2][3]-[4][5]
- Specify a code from below for each [1] through [5].
(e.g. M2SBS-6AA-M2/CE/Q)
- Ratios (e.g. $K_1 = 2.00$, $K_2 = 0.10$)
- Special input and output ranges (For codes Z&0)
- Specify the specification for option code /Q
(e.g. /C01/S01)

[1] INPUT 1

Current

- A: 4 - 20 mA DC (Input resistance 250 Ω)
- A1: 4 - 20 mA DC (Input resistance 50 Ω)
- B: 2 - 10 mA DC (Input resistance 500 Ω)
- C: 1 - 5 mA DC (Input resistance 1000 Ω)
- D: 0 - 20 mA DC (Input resistance 50 Ω)
- E: 0 - 16 mA DC (Input resistance 62.5 Ω)
- F: 0 - 10 mA DC (Input resistance 100 Ω)
- G: 0 - 1 mA DC (Input resistance 1000 Ω)
- H: 10 - 50 mA DC (Input resistance 100 Ω)
- J: 0 - 10 μ A DC (Input resistance 1000 Ω)
- K: 0 - 100 μ A DC (Input resistance 1000 Ω)
- GW: -1 - +1 mA DC (Input resistance 1000 Ω)
- FW: -10 - +10 mA DC (Input resistance 100 Ω)
- Z: Specify current (See INPUT SPECIFICATIONS)

Voltage

- 1: 0 - 10 mV DC (Input resistance 10 k Ω min.)

- 2: 0 - 100 mV DC (Input resistance 100 k Ω min.)
- 3: 0 - 1 V DC (Input resistance 1 M Ω min.)
- 4: 0 - 10 V DC (Input resistance 1 M Ω min.)
- 5: 0 - 5 V DC (Input resistance 1 M Ω min.)
- 6: 1 - 5 V DC (Input resistance 1 M Ω min.)
- 4W: -10 - +10 V DC (Input resistance 1 M Ω min.)
- 5W: -5 - +5 V DC (Input resistance 1 M Ω min.)
- 0: Specify voltage (See INPUT SPECIFICATIONS)

[2] INPUT 2

Same range availability as Input 1

[3] OUTPUT

Current

- A: 4 - 20 mA DC (Load resistance 750 Ω max.)
- B: 2 - 10 mA DC (Load resistance 1500 Ω max.)
- C: 1 - 5 mA DC (Load resistance 3000 Ω max.)
- D: 0 - 20 mA DC (Load resistance 750 Ω max.)
- E: 0 - 16 mA DC (Load resistance 900 Ω max.)
- F: 0 - 10 mA DC (Load resistance 1500 Ω max.)
- G: 0 - 1 mA DC (Load resistance 15 k Ω max.)
- Z: Specify current (See OUTPUT SPECIFICATIONS)

Voltage

- 1: 0 - 10 mV DC (Load resistance 10 k Ω min.)
- 2: 0 - 100 mV DC (Load resistance 100 k Ω min.)
- 3: 0 - 1 V DC (Load resistance 1000 Ω min.)
- 4: 0 - 10 V DC (Load resistance 10 k Ω min.)
- 5: 0 - 5 V DC (Load resistance 5000 Ω min.)
- 6: 1 - 5 V DC (Load resistance 5000 Ω min.)
- 4W: -10 - +10 V DC (Load resistance 10 k Ω min.)
- 5W: -5 - +5 V DC (Load resistance 5000 Ω min.)
- 0: Specify voltage (See OUTPUT SPECIFICATIONS)

[4] POWER INPUT

AC Power

- M2: 100 - 240 V AC (Operational voltage range 85 - 264 V, 47 - 66 Hz)
(90 - 264 V for UL)

DC Power

- R: 24 V DC
(Operational voltage range 24 V \pm 10 %, ripple 10 %p-p max.)
- R2: 11 - 27 V DC
(Operational voltage range 11 - 27 V, ripple 10 %p-p max.)
(Select 'N' for 'Standards & Approvals' code.)
- P: 110 V DC
(Operational voltage range 85 - 150 V, ripple 10 %p-p max.)
(110 V \pm 10 % for UL)

[5] OPTIONS (multiple selections)**STANDARDS & APPROVALS (must be specified)**

/N: Without CE or UL

/CE: CE marking

/UL: UL approval (CE marking)

OTHER OPTIONS

blank: none

/Q: Option other than the above (specify the specification)

(UL not available)

SPECIFICATIONS OF OPTION: Q (multiple selections)**COATING (For the detail, refer to M-System's web site.)**

/C01: Silicone coating

/C02: Polyurethane coating

/C03: Rubber coating

TERMINAL SCREW MATERIAL

/S01: Stainless steel

GENERAL SPECIFICATIONS**Construction:** Plug-in**Connection:** M3 screw terminals (torque 0.8 N·m)**Housing material:** Flame-resistant resin (black)**Isolation:** Input 1 or input 2 to output to power
(Negative sides of the input 1 and 2 must be of the same potential.)**Overrange output:** 0 to 120 % (approx.) at 1 - 5 V**Zero adjustment:** -5 to +5 % (front)**Span adjustment:** 95 to 105 % (front)**Equation:** Output = $K_1 \times \text{Input 1} - K_2 \times \text{Input 2}$ $(K_1 \times \text{Input 1} > K_2 \times \text{Input 2})$ K_1 : 0.40 to 2.00 specified when ordering K_2 : 0.10 to 2.00 specified when ordering

Input 1, Input 2: 0 to 120%

Forcibly limited to 0% and 120% respectively when the signal is out of range.

INPUT SPECIFICATIONS• **DC Current:** Input resistor incorporated
Specify input resistance value for code Z.
 $(R \leq 0.25 \text{ W} \div [\text{F.S. Current}]^2)$ • **DC Voltage:** -300 - +300 V DC**Minimum span:** 3 mV**Offset:** Max. 1.5 times span**Input resistance**Span 3 - 10 mV : $\geq 10 \text{ k}\Omega$ Span 10 - 100 mV : $\geq 10 \text{ k}\Omega$ Span 0.1 - 1 V : $\geq 100 \text{ k}\Omega$ Span $\geq 1 \text{ V}$: $\geq 1 \text{ M}\Omega$ **OUTPUT SPECIFICATIONS**• **DC Current:** 0 - 20 mA DC**Minimum span:** 1 mA**Offset:** Max. 1.5 times span**Load resistance:** Output drive 15 V max.• **DC Voltage:** -10 - +12 V DC**Minimum span:** 5 mV**Offset:** Max. 1.5 times span**Load resistance:** Output drive 1 mA max.; at $\geq 0.5 \text{ V}$ **INSTALLATION****Power Consumption**• **AC Power input:**

Approx. 3 VA at 100 V

Approx. 4 VA at 200 V

Approx. 5 VA at 264 V

• **DC Power input:** Approx. 3 W**Operating temperature:** -5 to +55°C (23 to 131°F)**Operating humidity:** 30 to 90 %RH (non-condensing)**Mounting:** Surface or DIN rail**Weight:** 150 g (0.33 lbs)**PERFORMANCE in percentage of span****Accuracy:** $\pm 0.2 \%$ ($\pm 0.4 \%$ with either or both K_1 , K_2 exceeding 1.00)**Temp. coefficient:** $\pm 0.015 \%/^{\circ}\text{C}$ ($\pm 0.008 \%/^{\circ}\text{F}$)**Response time:** $\leq 0.5 \text{ sec.}$ (0 - 90 %)**Line voltage effect:** $\pm 0.1 \%$ over voltage range**Insulation resistance:** $\geq 100 \text{ M}\Omega$ with 500 V DC**Dielectric strength:** 2000 V AC @1 minute (input 1 or input 2 to output to power to ground)**STANDARDS & APPROVALS****CE conformity:**

EMC Directive (2004/108/EC)

EN 61000-6-4 (EMI)

EN 61000-6-2 (EMS)

Low Voltage Directive (2006/95/EC)

EN 61010-1

Installation Category II

Pollution Degree 2

Max. operating voltage 300 V

Input 1 or input 2 or output to power: Reinforced insulation

Input 1 or input 2 to output: Basic insulation

Approval:

UL/C-UL nonincendive Class I, Division 2,

Groups A, B, C, and D hazardous locations

(UL 1604, CAN/CSA-C22.2 No.213)

UL/C-UL general safety requirements

(UL 61010B-1, CAN/CSA-C22.2 No.1010-1)

DIMENSIONS unit: mm (inch)

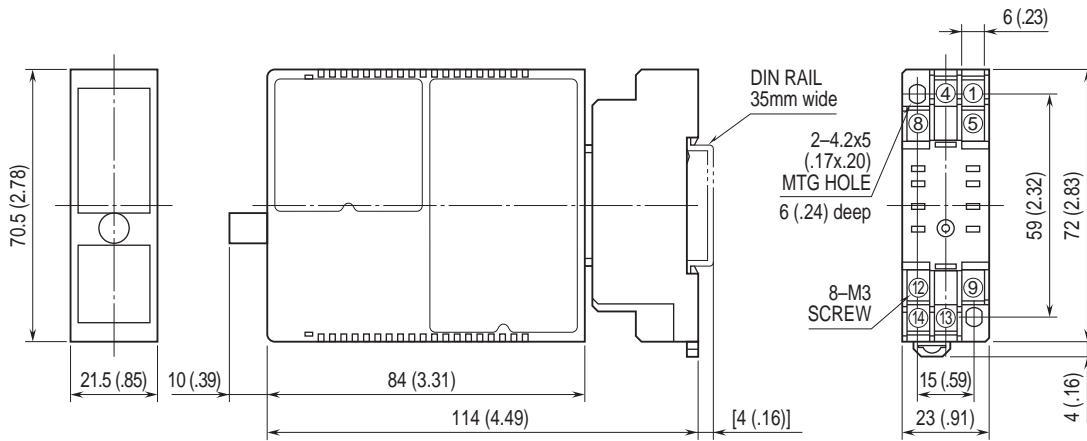

• When mounting, no extra space is needed between units.

SCHEMATIC CIRCUITRY & CONNECTION DIAGRAM

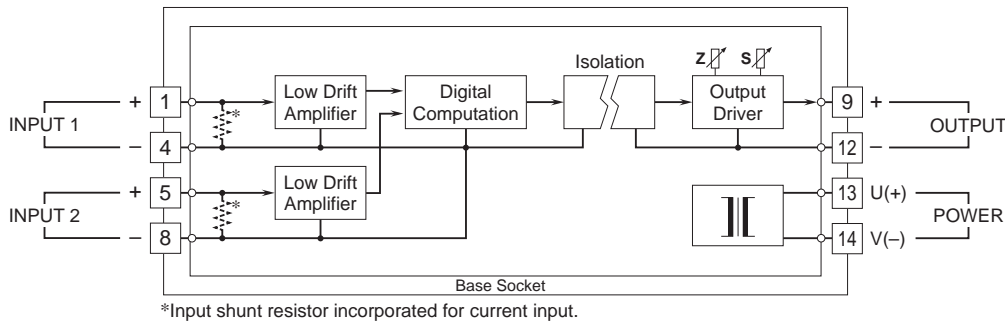

Specifications are subject to change without notice.