

Super-mini Signal Conditioners Mini-M Series

RATIO/BIAS TRANSMITTER

(input bias)

Functions & Features

- Provides precise matching of DC control signals to final control elements in open- or closed-loop systems
- Easy ratio/bias setting with the front digital display
- Ratio adjustable from 0.1 to 4.00 or from -0.1 to -4.00; Bias adjustable to $\pm 100\%$
- CE marking
- UL approval

Typical Applications

- Ratio control for air/fuel flows or for two flows
- Gain calculation for manipulated variable from a controller
- Large scale signal span adjustment

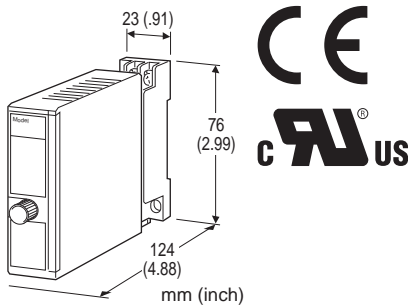

MODEL: M2RTS-[1]-[2][3]-[4][5]

ORDERING INFORMATION

- Code number: M2RTS-[1]-[2][3]-[4][5]
- Specify a code from below for each [1] through [5]. (e.g. M2RTS-S-6A-M2/CE/Q)
- Special input and output ranges (For codes Z & 0)
- Specify the specification for option code /Q (e.g. /C01/S01)

[1] OUTPUT CHARACTERISTICS

- S: Proportional; ratio 0.1 to 4.00
 R: Inverted; ratio -0.1 to -4.00

[2] INPUT

Current

- A: 4 - 20 mA DC (Input resistance 250 Ω)
 A1: 4 - 20 mA DC (Input resistance 50 Ω)
 B: 2 - 10 mA DC (Input resistance 500 Ω)
 C: 1 - 5 mA DC (Input resistance 1000 Ω)
 D: 0 - 20 mA DC (Input resistance 50 Ω)
 E: 0 - 16 mA DC (Input resistance 62.5 Ω)

- F: 0 - 10 mA DC (Input resistance 100 Ω)
 G: 0 - 1 mA DC (Input resistance 1000 Ω)
 H: 10 - 50 mA DC (Input resistance 100 Ω)
 K: 0 - 100 μ A DC (Input resistance 1000 Ω)
 GW: -1 - +1 mA DC (Input resistance 1000 Ω)
 FW: -10 - +10 mA DC (Input resistance 100 Ω)
 Z: Specify current (See INPUT SPECIFICATIONS)

Voltage

- 2: 0 - 100 mV DC (Input resistance 100 k Ω min.)
 3: 0 - 1 V DC (Input resistance 1 M Ω min.)
 4: 0 - 10 V DC (Input resistance 1 M Ω min.)
 5: 0 - 5 V DC (Input resistance 1 M Ω min.)
 6: 1 - 5 V DC (Input resistance 1 M Ω min.)
 4W: -10 - +10 V DC (Input resistance 1 M Ω min.)
 5W: -5 - +5 V DC (Input resistance 1 M Ω min.)
 0: Specify voltage (See INPUT SPECIFICATIONS)

[3] OUTPUT

Current

- A: 4 - 20 mA DC (Load resistance 750 Ω max.)
 B: 2 - 10 mA DC (Load resistance 1500 Ω max.)
 C: 1 - 5 mA DC (Load resistance 3000 Ω max.)
 D: 0 - 20 mA DC (Load resistance 750 Ω max.)
 E: 0 - 16 mA DC (Load resistance 900 Ω max.)
 F: 0 - 10 mA DC (Load resistance 1500 Ω max.)
 G: 0 - 1 mA DC (Load resistance 15 k Ω max.)
 Z: Specify current (See OUTPUT SPECIFICATIONS)

Voltage

- 1: 0 - 10 mV DC (Load resistance 10 k Ω min.)
 2: 0 - 100 mV DC (Load resistance 100 k Ω min.)
 3: 0 - 1 V DC (Load resistance 1000 Ω min.)
 4: 0 - 10 V DC (Load resistance 10 k Ω min.)
 5: 0 - 5 V DC (Load resistance 5000 Ω min.)
 6: 1 - 5 V DC (Load resistance 5000 Ω min.)
 4W: -10 - +10 V DC (Load resistance 10 k Ω min.)
 5W: -5 - +5 V DC (Load resistance 5000 Ω min.)
 0: Specify voltage (See OUTPUT SPECIFICATIONS)

[4] POWER INPUT

AC Power

- M2: 100 - 240 V AC (Operational voltage range 85 - 264 V, 47 - 66 Hz)
 (90 - 264 V for UL)

DC Power

- R: 24 V DC
 (Operational voltage range 24 V $\pm 10\%$, ripple 10 %p-p max.)
 R2: 11 - 27 V DC
 (Operational voltage range 11 - 27 V, ripple 10 %p-p max.)
 (Select 'N' for 'Standards & Approvals' code.)
 P: 110 V DC
 (Operational voltage range 85 - 150 V, ripple 10 %p-p max.)

(110 V ±10 % for UL)

[5] OPTIONS (multiple selections)

STANDARDS & APPROVALS (must be specified)

/N: Without CE or UL

/CE: CE marking

/UL: UL approval (CE marking)

OTHER OPTIONS

blank: none

/Q: Option other than the above (specify the specification)
(UL not available)

SPECIFICATIONS OF OPTION: Q (multiple selections)

COATING (For the detail, refer to M-System's web site.)

/C01: Silicone coating

/C02: Polyurethane coating

/C03: Rubber coating

TERMINAL SCREW MATERIAL

/S01: Stainless steel

GENERAL SPECIFICATIONS

Construction: Plug-in

Connection: M3 screw terminals (torque 0.8 N·m)

Housing material: Flame-resistant resin (black)

Isolation: Input to output to power

Overrange output: Approx. -10 to +120 % at 1 - 5 V

Ratio adjustment

Proportional: 0.10 to 4.00; 0.01 increments

Inverted: -0.10 to -4.00; 0.01 increments

Bias adjustment: -100 to +100 %; 1 % increments

Ratio/bias selector: Double-throw SW (front)

UP/DOWN control: Double-throw, momentary SW (front)

Equation: $X_o = K(X_i + B)$ (proportional)

$X_o = K(X_i + B) + 100\%$ (inverted)

where

X_o : Output (%)

K : Ratio

Linear characteristics

0.1 to 4.00 (proportional)

-0.1 to -4.00 (inverted)

X_i : Input (approx. -10 to +120 %)

B : Bias (-100 to +100 %)

INDICATORS

Ratio/bias digital display: Red LED; 6.4 mm (.25") 7 segment, 3 digits

Polarity indicator: Dual color (red/green) LED; Red with a positive set value; Green with a negative set value.

Power saving mode: Indicators turn off if the switches are untouched for 1 minute.

INPUT SPECIFICATIONS

• DC Current:

Shunt resistor attached to the input terminals (0.5 W)

Specify input resistance value for code Z.

• DC Voltage: -30 - +30 V DC

Minimum span: 100 mV

Offset: Max. 1.5 times span

Input resistance

Span 0.1 - 1 V : $\geq 100\text{ k}\Omega$

Span $\geq 1\text{ V}$: $\geq 1\text{ M}\Omega$

OUTPUT SPECIFICATIONS

• DC Current: 0 - 20 mA DC

Minimum span: 1 mA

Offset: Max. 1.5 times span

Load resistance: Output drive 15 V max.

• DC Voltage: -10 - +12 V DC

Minimum span: 5 mV

Offset: Max. 1.5 times span

Load resistance: Output drive 1 mA max.; at $\geq 0.5\text{ V}$

INSTALLATION

Power Consumption

• AC Power input:

Approx. 3 VA at 100 V

Approx. 4 VA at 200 V

Approx. 5 VA at 264 V

• DC Power input: Approx. 3 W

Operating temperature: -5 to +55°C (23 to 131°F)

Operating humidity: 30 to 90 %RH (non-condensing)

Mounting: Surface or DIN rail

Weight: 150 g (0.33 lbs)

PERFORMANCE in percentage of span

Accuracy: $\pm 0.2\%$

Ratio = 1, Bias = 0 % (proportional)

Ratio = -1, Bias = 0 % (inverted)

Temp. coefficient: $\pm 0.015\%/^{\circ}\text{C}$ ($\pm 0.008\%/^{\circ}\text{F}$)

Response time: $\leq 0.5\text{ sec.}$ (0 - 90 %)

Line voltage effect: $\pm 0.1\%$ over voltage range

Insulation resistance: $\geq 100\text{ M}\Omega$ with 500 V DC

Dielectric strength: 2000 V AC @1 minute (input to output to power to ground)

STANDARDS & APPROVALS

CE conformity:

EMC Directive (2004/108/EC)

EN 61000-6-4 (EMI)

EN 61000-6-2 (EMS)

Low Voltage Directive (2006/95/EC)

EN 61010-1

Installation Category II

Pollution Degree 2

Max. operating voltage 300 V

Input or output to power: Reinforced insulation

Input to output: Basic insulation

Approval:

UL/C-UL nonincendive Class I, Division 2,

Groups A, B, C, and D hazardous locations

(ANSI/ISA-12.12.01, CAN/CSA-C22.2 No.213)

UL/C-UL general safety requirements

(UL 61010B-1, CAN/CSA-C22.2 No.1010-1)

EXTERNAL VIEW

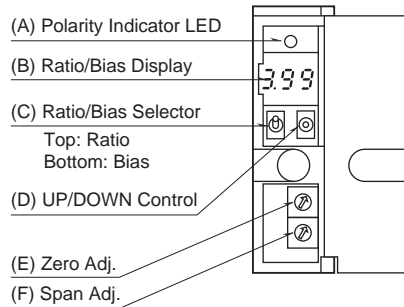

The front cover cannot be turned open by 180 deg. when there is no extra space between units.

• How to Set the Ratio

Turn the Ratio/Bias Selector (C) to the top.

The Ratio/Bias Display (B) shows the current ratio (0.10 – 4.00). Press UP/DOWN Control (D) until the display shows a desired set value.

The Polarity Indicator LED (A) is red when the set value is in positive range, green when in negative range.

• How to Set the Bias

Turn the Ratio/Bias Selector (C) to the bottom.

The Ratio/Bias Display (B) shows the current bias (0 – 100%). Press UP/DOWN Control (D) until the display shows a desired set value.

The Polarity Indicator LED (A) is red when the set value is in positive range, green when in negative range.

• Fine Calibration

Equation:

$$X_o = K(X_i + B) \text{ (proportional)}$$

$$X_o = K(X_i + B) + 100 \% \text{ (inverted)}$$

1) Calculate the input signal X_i which results in 0 % output. Apply the calculated input and adjust with Zero Adj. (E) the output X_o to 0 %.

2) Calculate the input signal X_i which results in 100 % output. Apply the calculated input and adjust with Span

Adj. (E) the output X_o to 100 %.

3) Apply the calculated zero point input again and check the output X_o .

4) If the output has been shifted, go through (1) through (3) again.

The unit is factory set and calibrated to the following ratio and bias values.

Proportional characteristics: ratio (K) = 1, Bias (B) = 0 %

Inverted characteristics: ratio (K) = -1, Bias (B) = 0 %

EXTERNAL DIMENSIONS & TERMINAL ASSIGNMENTS unit: mm (inch)

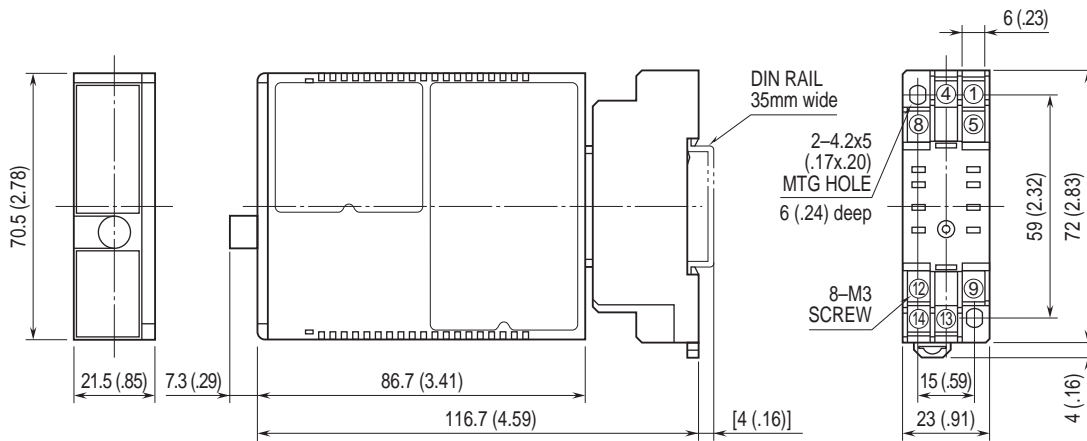

• When mounting, no extra space is needed between units.

TERMINAL ASSIGNMENTS unit: mm (inch)

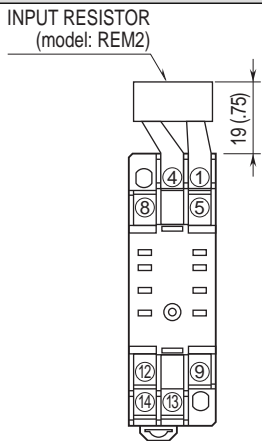

Input shunt resistor attached for current input.

SCHEMATIC CIRCUITRY & CONNECTION DIAGRAM

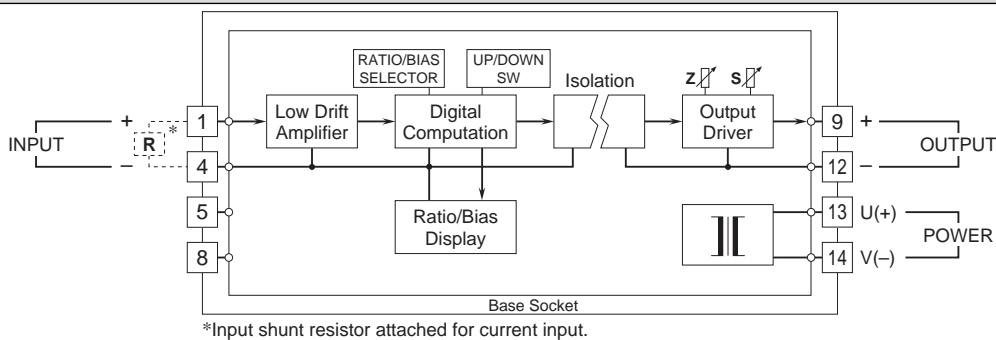

Specifications are subject to change without notice.