

Super-mini Signal Conditioners Mini-M Series

7: 20 mV/V
0: Specify (strain gauge and excitation)

STRAIN GAUGE TRANSMITTER

Functions & Features

- Provides a DC output signal compatible with a bridge type strain gauge utilized in load cells, pressure transducers
- Supplies required excitation voltage
- Excitation adjustable from 2 V to 10 V
- Wide-range adjustment: 0 - 80 % for zero, 100 - 20 % for span
- Three-way isolation
- CE marking
- UL approval

Typical Applications

- Weighing system for tanks, hoppers, silos
- Weighing system using cranes
- Float level meter utilizing strain gauges

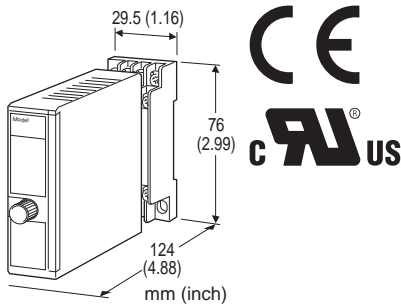

MODEL: M2LCS-[1][2]-[3][4]

ORDERING INFORMATION

- Code number: M2LCS-[1][2]-[3][4]
Specify a code from below for each [1] through [4].
(e.g. M2LCS-2A-M2/K/CE/Q)
- Special output range (For codes Z & 0)
- Specify the specification for option code /Q
(e.g. /C01/S01)

Note: Must be used with its socket. NOT installable to a multi-unit installation base. (e.g. model: M2BS-16)

[1] INPUT STRAIN GAUGE

- 1: 1 mV/V
- 12: 1.25 mV/V
- 15: 1.5 mV/V
- 2: 2 mV/V
- 3: 3 mV/V
- 4: 4 mV/V
- 5: 5 mV/V
- 6: 10 mV/V

[2] OUTPUT

Current

- A: 4 - 20 mA DC (Load resistance 750 Ω max.)
- B: 2 - 10 mA DC (Load resistance 1500 Ω max.)
- C: 1 - 5 mA DC (Load resistance 3000 Ω max.)
- D: 0 - 20 mA DC (Load resistance 750 Ω max.)
- E: 0 - 16 mA DC (Load resistance 900 Ω max.)
- F: 0 - 10 mA DC (Load resistance 1500 Ω max.)
- G: 0 - 1 mA DC (Load resistance 15 kΩ max.)
- Z: Specify current (See OUTPUT SPECIFICATIONS)

Voltage

- 1: 0 - 10 mV DC (Load resistance 10 kΩ min.)
- 2: 0 - 100 mV DC (Load resistance 100 kΩ min.)
- 3: 0 - 1 V DC (Load resistance 1000 Ω min.)
- 4: 0 - 10 V DC (Load resistance 10 kΩ min.)
- 5: 0 - 5 V DC (Load resistance 5000 Ω min.)
- 6: 1 - 5 V DC (Load resistance 5000 Ω min.)
- 4W: -10 - +10 V DC (Load resistance 10 kΩ min.)
- 5W: -5 - +5 V DC (Load resistance 5000 Ω min.)
- 0: Specify voltage (See OUTPUT SPECIFICATIONS)

[3] POWER INPUT

AC Power

- M2: 100 - 240 V AC (Operational voltage range 85 - 264 V, 47 - 66 Hz)
(90 - 264 V for UL)

DC Power

- R: 24 V DC
(Operational voltage range 24 V ±10 %, ripple 10 %p-p max.)
- R2: 11 - 27 V DC
(Operational voltage range 11 - 27 V, ripple 10 %p-p max.)
(Select '/N' for 'Standards & Approvals' code.)
- P: 110 V DC
(Operational voltage range 85 - 150 V, ripple 10 %p-p max.)
(110 V ±10 % for UL)

[4] OPTIONS (multiple selections)

Response Time (0 - 90 %)

- blank: Standard (≤ 0.5 sec.)
- /K: Fast Response (Approx. 25 msec.)

Standards & Approvals (must be specified)

- /N: Without CE or UL
- /CE: CE marking
- /UL: UL approval, CE marking

Other Options

- blank: none
- /Q: Option other than the above (specify the specification)
(UL not available)

SPECIFICATIONS OF OPTION: Q (multiple selections)

COATING (For the detail, refer to M-System's web site.)

/C01: Silicone coating

/C02: Polyurethane coating

/C03: Rubber coating

TERMINAL SCREW MATERIAL

/S01: Stainless steel

GENERAL SPECIFICATIONS

Construction: Plug-in

Connection: M3 screw terminals (torque 0.8 N·m)

Housing material: Flame-resistant resin (black)

Isolation: Input to output to power

Overrange output: Approx. -10 to +120 % at 1 - 5 V

Excitation adjustment: 2 - 10 V (front)

Zero adjustments (tare): 0 - 80 % (front)

(May not applicable when the excitation voltage is changed after shipment.)

Span adjustment: 100 - 20 % (front)

(May not applicable when the excitation voltage is changed after shipment.)

INPUT SPECIFICATIONS

■ **Input:** Bridge voltage from load cells

• **Strain Gauge**

Rated output from strain gauge: 1 - 20 mV/V;

Input to the M2LCS must be over 3mV.

• **Excitation:** 2 - 10 V adjustable (5 V standard)

Maximum current: 35 mA

OUTPUT SPECIFICATIONS

■ **DC Current:** 0 - 20 mA DC

Minimum span: 1 mA

Offset: Max. 1.5 times span

Load resistance: Output drive 15 V max.

■ **DC Voltage:** -10 - +12 V DC

Minimum span: 5 mV

Offset: Max. 1.5 times span

Load resistance: Output drive 1 mA max.; at ≥ 0.5 V

INSTALLATION

Power Consumption

• **AC Power input:**

Approx. 3 VA at 100 V

Approx. 4 VA at 200 V

Approx. 5 VA at 264 V

• **DC power input:** Approx. 3 W

Operating temperature: -5 to +55°C (23 to 131°F)

Operating humidity: 30 to 90 %RH (non-condensing)

Mounting: Surface or DIN rail

Weight: 150 g (0.33 lbs)

PERFORMANCE in percentage of span

Accuracy: ± 0.1 % (Input ≥ 3 mV)

Linearity: ± 0.05 % (Input ≥ 3 mV)

Temp. coefficient: ± 0.02 %/°C (± 0.01 %/°F) (input ≥ 3 mV)

Line voltage effect: ± 0.1 % over voltage range

Insulation resistance: ≥ 100 M Ω with 500 V DC

Dielectric strength: 2000 V AC @1 minute (input to output to power to ground)

STANDARDS & APPROVALS

CE conformity:

EMC Directive (2004/108/EC)

EMI EN 61000-6-4: 2007

EMS EN 61000-6-2: 2005

Low Voltage Directive (2006/95/EC)

EN 61010-1: 2001

Installation Category II

Pollution Degree 2

Input or output to power: Reinforced insulation (300 V)

Input to output: Basic insulation (300 V)

Approval:

UL/C-UL nonincendive Class I, Division 2,

Groups A, B, C, and D hazardous locations

(ANSI/ISA-12.12.01:2007, CAN/CSA-C22.2 No.213:1987)

UL/C-UL general safety requirements

(UL 61010B-1:2003, CAN/CSA-C22.2 No.61010-1:1992)

FRONT VIEW

(with the cover open)

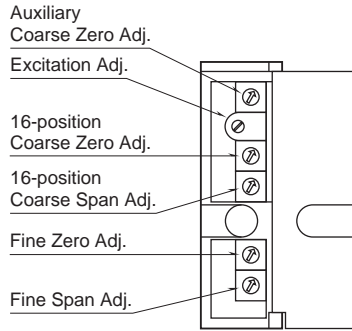

- **Coarse Zero Adj. (auxiliary):** Used when the zero cannot be adjusted with only the coarse and fine zero adjustments.
- **Excitation Adj.:** Factory adjusted.
- **Coarse Zero Adj.:** Tare adjustment. Approx. 5 % of input span adjustable with each increment. Max. 80 % by 16 positions.
- **Coarse Span Adj.:** Gain adjustment. 100 - 20 % of input span adjusted by 16 positions.
- **Fine Zero Adj.:** Tare adjustment
- **Fine Span Adj.:** Gain adjustment

EXTERNAL DIMENSIONS & TERMINAL ASSIGNMENTS unit: mm (inch)

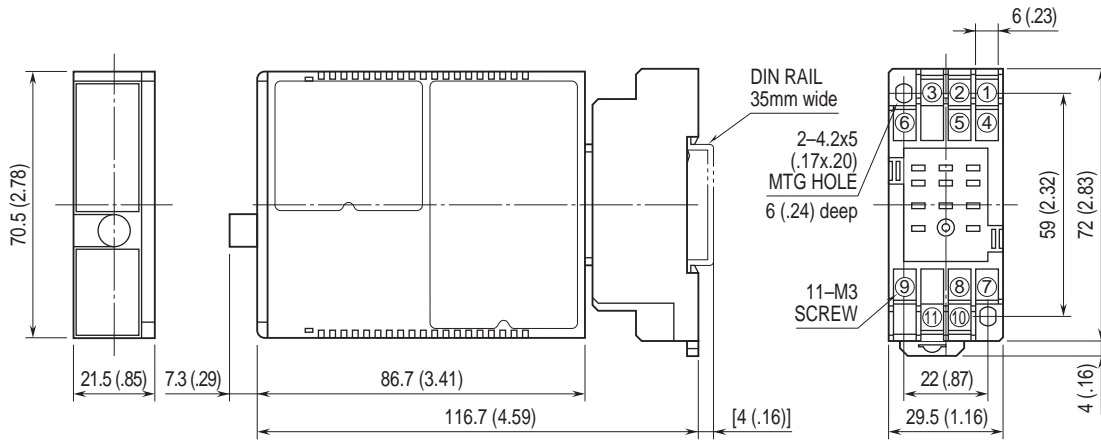

• When mounting, no extra space is needed between units.

SCHEMATIC CIRCUITRY & CONNECTION DIAGRAM

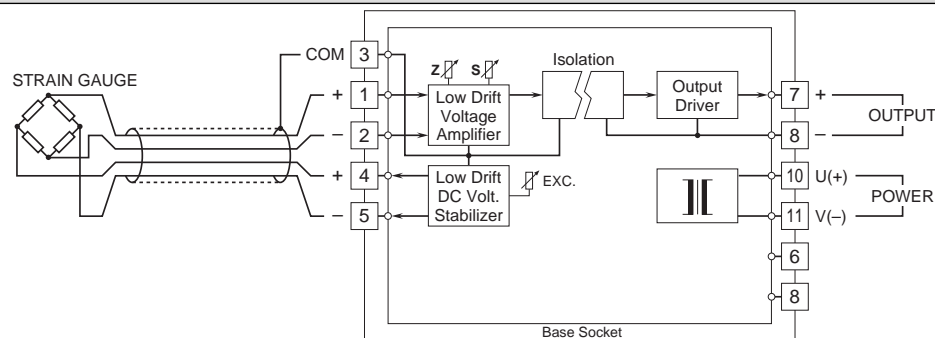



Specifications are subject to change without notice.