

Plug-in Signal Conditioners M-UNIT

SPLIT-RANGE TRANSMITTER

Functions & Features

- Generating two signals which control two final control elements
- High-density mounting

Typical Applications

- Balancing two final control elements in opposite actions used in heating-cooling or humidifying-dehumidifying processes

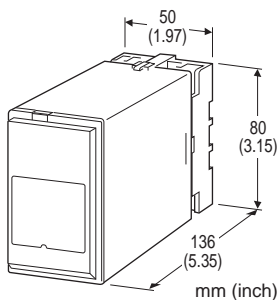

MODEL: MFS-[1]-[2][3][4]-[5]

ORDERING INFORMATION

- Code number: MFS-[1]-[2][3][4]-[5]
Specify a code from below for each [1] through [5].
(e.g. MFS-V-AAA-B)

[1] OUTPUT CHARACTERISTICS

V: V-shape

P: Parallel

Output 2 is assigned to the reversed output in V-shape characteristics.

[2] INPUT

Current

A: 4 - 20 mA DC (Input resistance 250 Ω)

Voltage

4: 0 - 10 V DC (Input resistance 200 k Ω min.)

I/O combination available AAA or 444 suffix codes only.

[3] OUTPUT 1

Current

A: 4 - 20 mA DC (Load resistance 600 Ω max.)

Voltage

4: 0 - 10 V DC (Load resistance 10 k Ω min.)

50 - 100 % with V-shape

50 - 100 % with parallel

0 - 100 % for factory setting

[4] OUTPUT 2

Current

A: 4 - 20 mA DC (Load resistance 600 Ω max.)

Voltage

4: 0 - 10 V DC (Load resistance 10 k Ω min.)

50 - 0 % with V-shape

0 - 50 % with parallel

0 - 100 % for factory setting

[5] POWER INPUT

AC Power

B: 100 V AC

C: 110 V AC

D: 115 V AC

F: 120 V AC

G: 200 V AC

H: 220 V AC

J: 240 V AC

DC Power

R: 24 V DC

GENERAL SPECIFICATIONS

Construction: Plug-in

Connection: M3.5 screw terminals

Housing material: Flame-resistant resin (black)

Isolation: Input or output 1 or output 2 to power

Input range: 0 - 23.2 mA DC or -1 - +12 V DC

Output range: 0 - 23.2 mA DC or -1 - +12 V DC

Output characteristics

- **V-shape:** two signals vary in opposite directions; used when both final control devices have the same action (direct-direct or reverse-reverse).

- **Parallel:** two signals vary in the same direction; used when one final control device is direct and another is reverse.

Monitor jacks: Direct monitoring of output signal; accessible at front

- **Ammeter requirement:** Input resistance 10 Ω max. (for current output)

Monitor jack diameter: 2 mm (.08")

INPUT SPECIFICATIONS

- **DC Current:** Input resistor incorporated

INSTALLATION

Power input

- **AC:** Operational voltage range: rating ± 10 %, 50/60 ± 2 Hz, approx. 3 VA

- DC: Operational range: 24 V \pm 10 %, approx. 80 mA (ripple 10 %p-p max.)
- Operating temperature: -5 to +60°C (23 to 140°F)
- Operating humidity: 30 to 90 %RH (non-condensing)
- Mounting: Surface or DIN rail
- Weight: 400 g (0.88 lbs)

PERFORMANCE in percentage of span

- Accuracy: \pm 0.3 % (gain = 1 or -1)
- Temp. coefficient: \pm 0.02 %/°C (\pm 0.01 %/°F)
- Response time: \leq 0.5 sec. (0 - 90 %)
- Line voltage effect: \pm 0.1 % over voltage range
- Insulation resistance: \geq 100 M Ω with 500 V DC
- Dielectric strength: 2000 V AC @ 1 minute (input or output 1 or output 2 to power to ground)

EXTERNAL VIEW

■ FRONT VIEW (current output; with cover open)

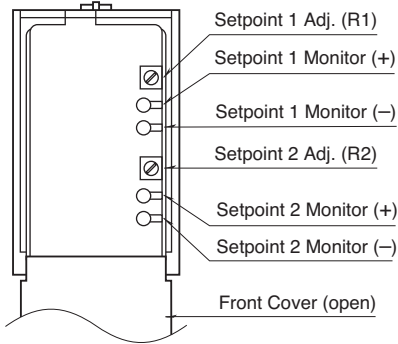

■ FRONT VIEW (voltage output; with cover open)

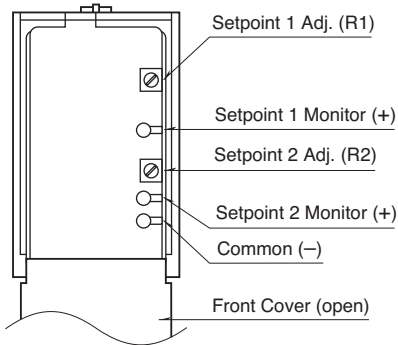

EXTERNAL DIMENSIONS & TERMINAL ASSIGNMENTS unit: mm (inch)

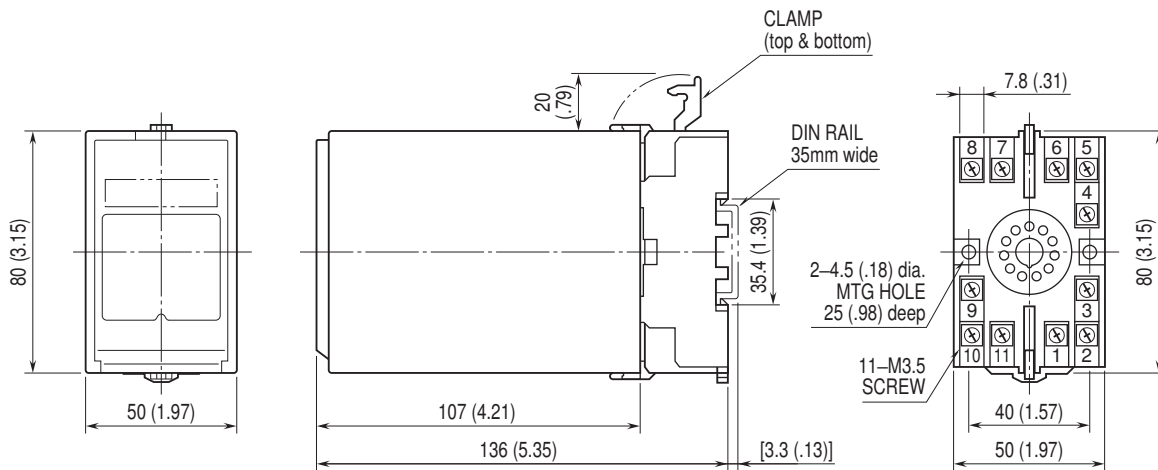

• When mounting, no extra space is needed between units.

SCHEMATIC CIRCUITRY & CONNECTION DIAGRAM

■ CURRENT OUTPUT

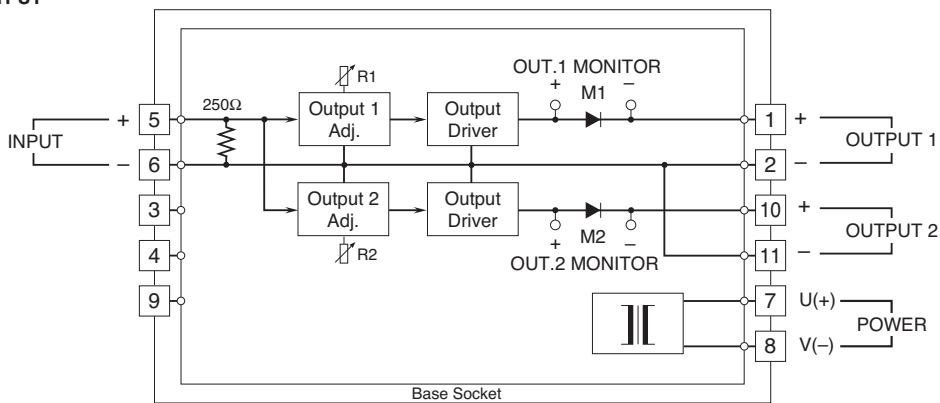

■ VOLTAGE OUTPUT

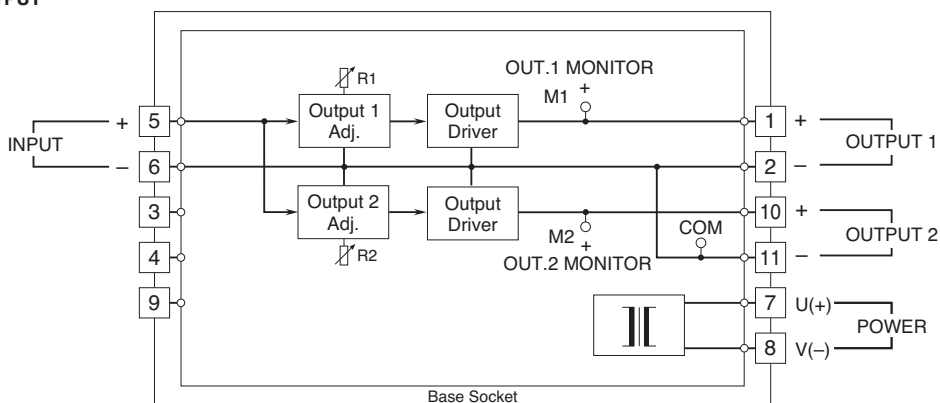

OPERATION DIAGRAM

■V-SHAPE CHARACTERISTICS (model: MFS-V)

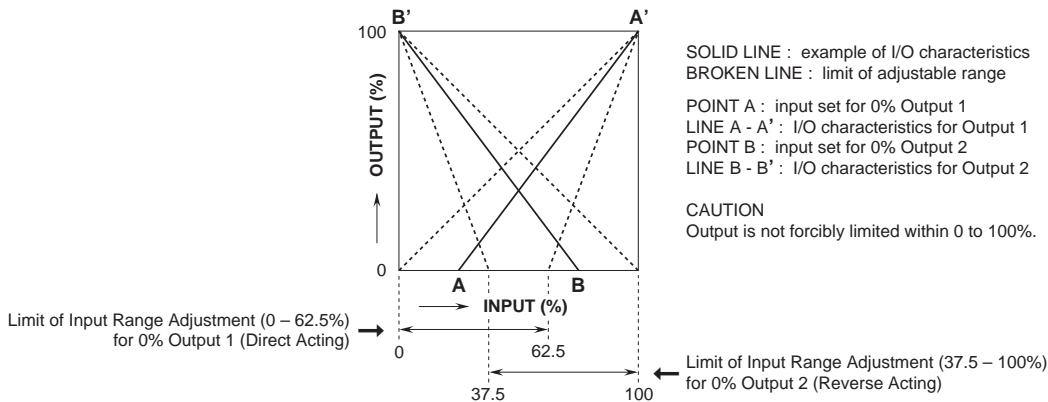

•Input Range Adjustment

- For current output, connect an ammeter to output 1 monitor terminals.
 Current signal is measured at both ends of a diode inserted in series to the output 1 driver.
 Input resistance of the ammeter must be 10 at the maximum to ensure accurate measurement.
 For voltage output, connect a voltmeter across the common and output 1 monitor (+) terminals.
- Apply an input signal desired for 0% output. (within 0 – 62.5%)
- Turn output 1 adjustment until 0% output is monitored.
- Adjust output 2 the same way as output 1. Allowable input range for 0% output is 37.5 – 100%.
 Input signals for 100% output are fixed to 100% for output 1, 0% for output 2.

■PARALLEL CHARACTERISTICS (model: MFS-P)

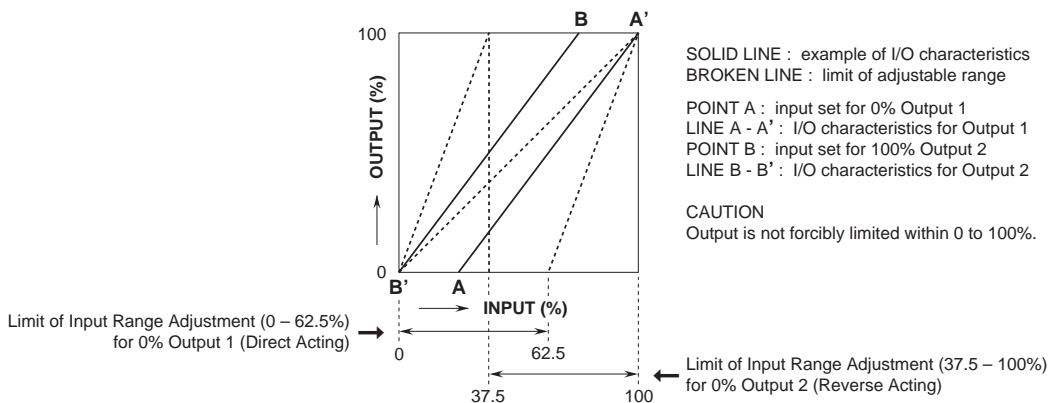

•Input Range Adjustment

- For current output, connect an ammeter to output 1 monitor terminals.
 Current signal is measured at both ends of a diode inserted in series to output 1 driver.
 Input resistance of the ammeter must be 10 at the maximum to ensure accurate measurement.
 For voltage output, connect a voltmeter across the common and output 1 monitor (+) terminals.
 - Apply an input signal desired for 0% output. (within 0 – 62.5%)
 - Turn output 1 adjustment until 0% output is monitored.
- Proceed to output 2 adjustment.
- Connect an ammeter or voltmeter to output 2 monitor terminal.
 - Apply input signal required for 100% output. (within 37.5 – 100%)
 - Turn output 2 adjustment until 100% output is monitored.
- For output 1, input signal for 100% output is fixed to 100%, while for output 2, input signal for 0% output is fixed to 0%.

■V-SHAPE CHARACTERISTICS (model: MFS-V)

- When the relation between control signal and valve-opening for both valves has the same characteristic:

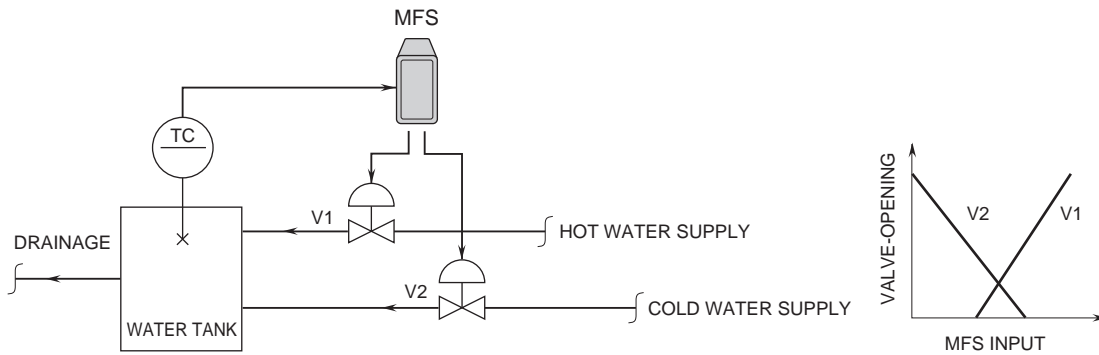

■PARALLEL CHARACTERISTICS (model: MFS-P)

- When the relation between control signal and valve-opening for one valve has the opposite characteristic to the other's:

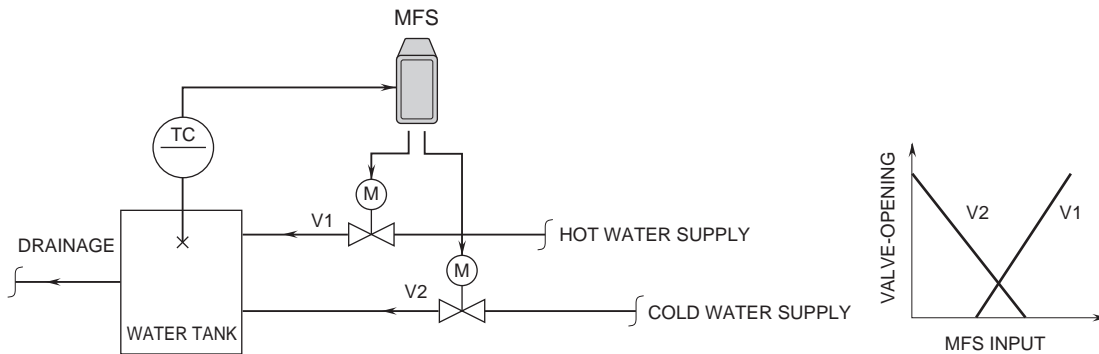

- To control wide flow range with two valves of different capacities:

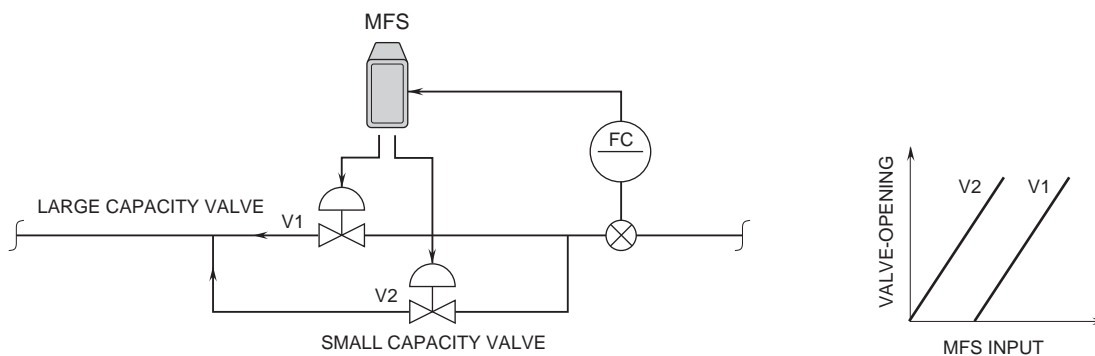

Specifications are subject to change without notice.