

## Plug-in Signal Conditioners M-UNIT

### STRAIN GAUGE TRANSMITTER

(remote sensing, super-high speed, 10 V / 120 mA excitation)

#### Functions & Features

- Provides a DC output signal compatible with a bridge type strain gauge utilized in load cells, pressure transducers
- Response time 300  $\mu$ sec.
- Six-wire remote sensing compensates for lead resistance variations
- Excitation adjustable from 2 V to 10 V, max. 120 mA
- Wide-range adjustment: 0 - 80 % for zero, 100 - 20 % for span
- Three-way isolation
- High-density mounting

#### Typical Applications

- Weighing system for tanks, hoppers, silos
- Weighing system using cranes
- Float level meter utilizing strain gauges

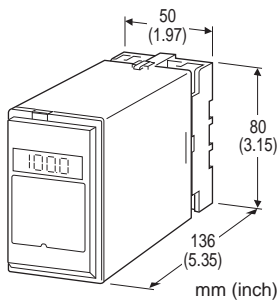

### MODEL: LCF-[1][2]-[3][4]

#### ORDERING INFORMATION

- Code number: LCF-[1][2]-[3][4]
- Specify a code from below for each [1] through [4]. (e.g. LCF-2A-B/E)
- Special output range (For codes Z & 0)

#### [1] INPUT STRAIN GAUGE

- 1: 1 mV/V
- 12: 1.25 mV/V
- 15: 1.5 mV/V
- 2: 2 mV/V
- 3: 3 mV/V
- 4: 4 mV/V
- 5: 5 mV/V
- 6: 10 mV/V
- 7: 20 mV/V

0: Specify (strain gauge and excitation)

#### [2] OUTPUT

##### Current

- A: 4 - 20 mA DC (Load resistance 750  $\Omega$  max.)
- B: 2 - 10 mA DC (Load resistance 1500  $\Omega$  max.)
- C: 1 - 5 mA DC (Load resistance 3000  $\Omega$  max.)
- D: 0 - 20 mA DC (Load resistance 750  $\Omega$  max.)
- E: 0 - 16 mA DC (Load resistance 900  $\Omega$  max.)
- F: 0 - 10 mA DC (Load resistance 1500  $\Omega$  max.)
- G: 0 - 1 mA DC (Load resistance 15 k $\Omega$  max.)
- Z: Specify current (See OUTPUT SPECIFICATIONS)

##### Voltage

- 1: 0 - 10 mV DC (Load resistance 10 k $\Omega$  min.)
- 2: 0 - 100 mV DC (Load resistance 100 k $\Omega$  min.)
- 3: 0 - 1 V DC (Load resistance 1000  $\Omega$  min.)
- 4: 0 - 10 V DC (Load resistance 10 k $\Omega$  min.)
- 5: 0 - 5 V DC (Load resistance 5000  $\Omega$  min.)
- 6: 1 - 5 V DC (Load resistance 5000  $\Omega$  min.)
- 4W: -10 - +10 V DC (Load resistance 10 k $\Omega$  min.)
- 5W: -5 - +5 V DC (Load resistance 5000  $\Omega$  min.)
- 0: Specify voltage (See OUTPUT SPECIFICATIONS)

#### [3] POWER INPUT

##### AC Power

- B: 100 V AC
- C: 110 V AC
- F: 120 V AC
- G: 200 V AC
- H: 220 V AC
- J: 240 V AC

#### [4] OPTIONS

##### Input Signal Indicator

- blank: Without
- /E: With (0.0 - 100.0 % display)

#### GENERAL SPECIFICATIONS

**Construction:** Plug-in

**Connection:** M3.5 screw terminals

**Housing material:** Flame-resistant resin (black)

**Isolation:** Input to output to power

**Overrange output:** Approx. -10 to +120 % at 1 - 5 V

**Excitation:** Adjustable from 2 to 10 V (front); limited to  $\leq$  15 V when the remote sensing terminals are open.

**Zero adjustments (tare):** 0 - 80 % (front)

(May not applicable when the excitation voltage is changed after shipment.)

**Span adjustment:** 100 - 20 % (front)

(May not applicable when the excitation voltage is changed)

after shipment.)

**LCD meter:** Indicating input; 0.1 % increments

EN 61010-1

Installation Category II

Pollution Degree 2

Input or output to power – Basic insulation (300 V)

## INPUT SPECIFICATIONS

**Input:** Bridge voltage from load cells

**Allowable leadwire resistance:**

Total Resistance [ $\Omega$ ] (of all wires) < (Bridge Resistance [ $\Omega$ ] / Excitation [V])  $\times$  1.2 [V]

• **Strain Gauge**

**Rated output from strain gauge:** 1 – 20 mV/V;

Input to the LCF must be over 3 mV.

• **Excitation:** 2 – 10 V adjustable (5 V standard)

**Maximum current:** 120 mA

## OUTPUT SPECIFICATIONS

• **DC Current:** 0 – 20 mA DC

**Minimum span:** 1 mA

**Offset:** Max. 1.5 times span

**Load resistance:** Output drive 15 V max.

• **DC Voltage:** -10 – +12 V DC

**Minimum span:** 5 mV

**Offset:** Max. 1.5 times span

**Load resistance:** Output drive 1 mA max. at  $\geq$  0.5 V

## INSTALLATION

**Power input**

• **AC:** Operational voltage range: rating  $\pm$ 10 %, 50/60  $\pm$  2 Hz, approx. 5 VA

**Operating temperature:** -5 to +60°C (23 to 140°F)

**Operating humidity:** 30 to 90 %RH (non-condensing)

**Mounting:** Surface or DIN rail

**Weight:** 400 g (0.88 lbs)

## PERFORMANCE in percentage of span

**Accuracy:**  $\pm$ 0.1 %

**Linearity:**  $\pm$ 0.05 %

**Temp. coefficient:**  $\pm$ 0.02 %/°C ( $\pm$ 0.01 %/°F)

**Response time:**  $\leq$  300  $\mu$ sec. (0 – 90 %), 2 kHz (-3 dB)

**Line voltage effect:**  $\pm$ 0.1 % over voltage range

**Insulation resistance:**  $\geq$  100 M $\Omega$  with 500 V DC

**Dielectric strength:** 2000 V AC @ 1 minute (input or output to power to ground)

1000 V AC @ 1 minute (input to output)

## STANDARDS & APPROVALS

**CE conformity:**

EMC Directive (2004/108/EC)

EMI EN 61000-6-4

EMS EN 61000-6-2

Low Voltage Directive (2006/95/EC)

## EXTERNAL VIEW

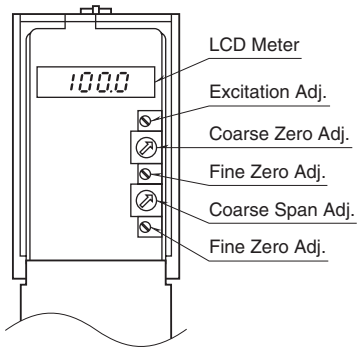

## EXTERNAL DIMENSIONS & TERMINAL ASSIGNMENTS unit: mm (inch)

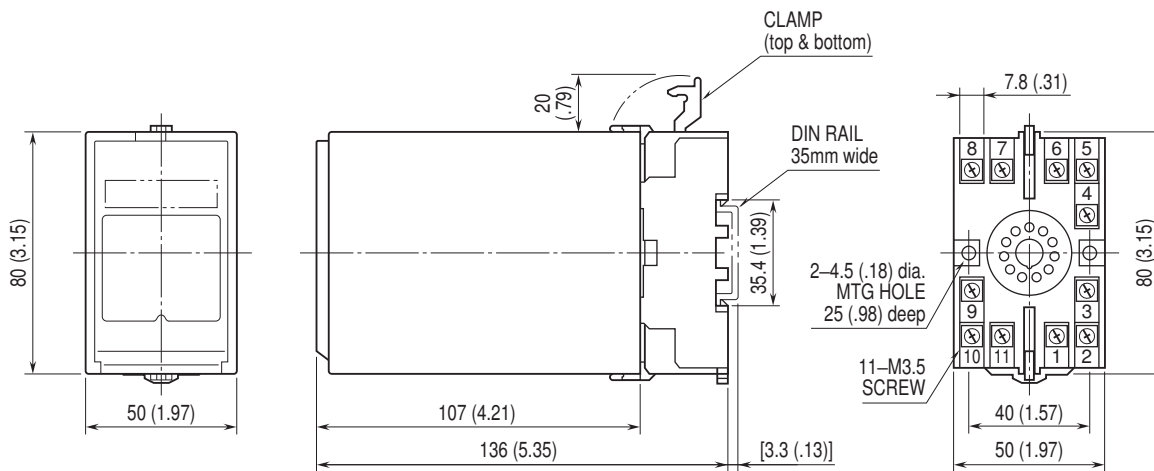

• When mounting, no extra space is needed between units.

## SCHEMATIC CIRCUITRY & CONNECTION DIAGRAM

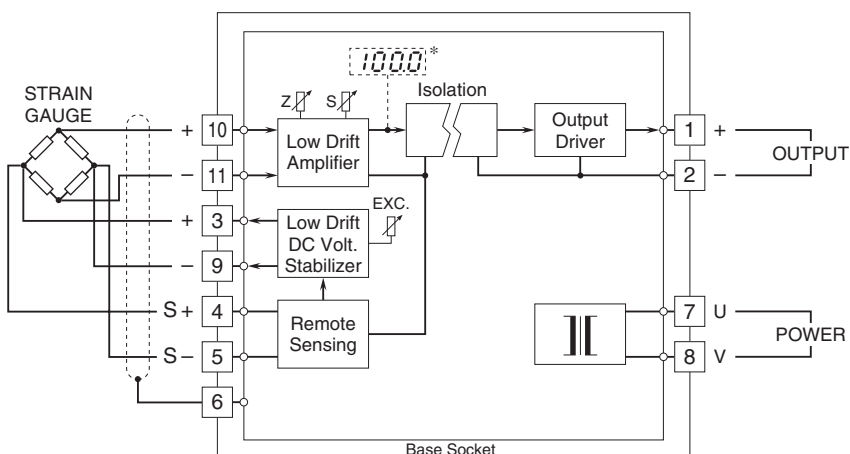

Close across the terminal 3 – 4 and 5 – 9 when the remote sensing is not used.  
\*Option /E

Specifications are subject to change without notice.