

Plug-in Signal Conditioners M-UNIT

ANALOG BACKUP STATION

MODEL

JB

MODEL & SUFFIX CODE SELECTION

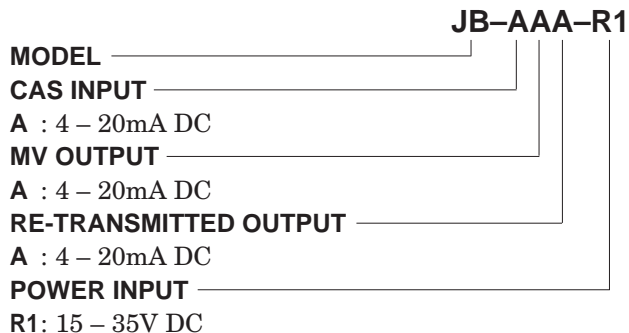

ORDERING INFORMATION

Specify code number. (e.g. JB-AAA-R1)
 Use Ordering Information Sheet (No. ESU-2641) to specify details of the backup operation mode. Default setting will be used if not otherwise specified.

RELATED PRODUCTS

- Programming unit (model: PU-2□)
- JX configurator connection kit (model: JXCON)

GENERAL SPECIFICATIONS

Construction: plug-in
Connection: M3.5 screw terminals
Housing material: flame-resistant resin (black)
Isolation: CAS input or MV output to contact input or power to re-transmitted output to contact output
Indicator LED: RUN output (green), MAN status output (red), UP command (red), DOWN command (red), MAN command (red)
Alarm output: RUN contact turns OFF when the high/low alarm for the CAS input trips.
Adjustments: Programming Unit (model: PU-2□); sliding-back response time, UP-DOWN response time, alarm, etc.

DISCONTINUED MODEL

Replaced with Model JB2

Functions & Features

- Enabling manual loading providing hold/increase/decrease signals to a device controlled by PID controller
- When the PID controller fails, the JB output goes back the preset time period and holds the cascade control signal of that moment (Retroactive function)
- Cascade control loop does not open even when the JB itself fails
- Manual control output transits smoothly to the cascade control mode in the preset response time (Sliding-back function)
- Isolated re-transmitted output
- Parameters set via hand-held programmer PU-2□
- Can be driven on battery power supply (35V DC max.)

Typical Applications

- Backup hold/manual loading for the DCS or computer control output failure

INPUT & OUTPUT

INPUT

• **CAS Input:** 4 – 20mA DC
Input resistance: 25Ω in manual control mode

• **Contact Input:** MAN control command and UP/DOWN command

Sensing: 5V DC @3mA
ON/OFF level: ≤200Ω for ON, ≥100kΩ for OFF

OUTPUT

• **MAN Output:** 4 – 20mA DC
Load resistance
CAS control mode: allowable load for CAS signal minus 50Ω
MAN control mode: 0 – 750Ω

• **Re-transmitted Output:** 4 – 20mA DC
Load resistance: 0 – 350Ω

• **Relay Outputs:** MAN status and RUN output; 120V AC @1A or 24V DC @1A
Electrical life: 10⁵ cycles
Mechanical life: 2 × 10⁷ cycles

INSTALLATION

Power input: operational voltage range 15 – 35V DC
 (ripple 10% p-p max.)
 approx. 120mA at 24V (CAS mode)
 approx. 180mA at 24V (MAN mode)

Operating temperature: -5 to +55°C (23 to 131°F)

Operating humidity: 30 to 90% RH (non-condensing)

Mounting: surface or DIN rail

Dimensions: W72×H80×D136 mm (2.83"×3.15"×5.35")

Weight: 450 g (0.99 lbs)

PERFORMANCE in percentage of span

Alarm setting accuracy: ±0.5%

Re-transmitted output accuracy: ±0.4%

CAS to MAN switching accuracy: ±0.5%

Temp. coefficient: ±0.015%/°C (±0.008%/°F)

Output memory at power failure: ≥10 seconds

Insulation resistance: ≥100MΩ with 500V DC

Dielectric strength: 1000V AC @1 minute
 (CAS input or MV output to contact
 input or power to re-transmitted output
 to contact output)
 1500V AC @1 minute
 (CAS input or MV output or contact
 input or power or re-transmitted output
 or contact output to ground)

FRONT PANEL CONFIGURATION

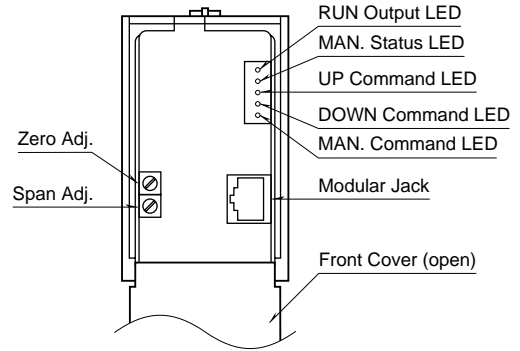

SCHEMATIC CIRCUITRY & CONNECTION DIAGRAM

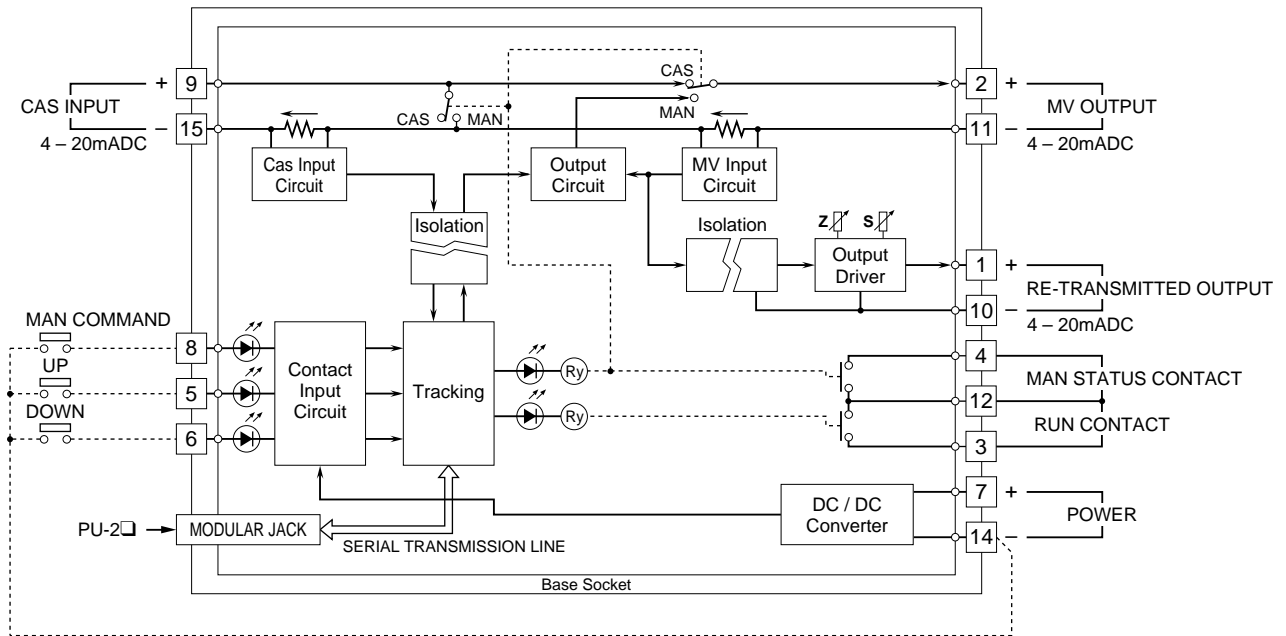

Specifications subject to change without notice.

OPERATION

■ Cascade Control Mode

The JB allows the CAS input (cascade control signal) from the PID controller to pass through at the MV output terminals.

■ Manual Control Mode

When the external MAN command relay is closed, the JB turns on to manual control mode.

Actual output signal is determined by following three operation modes:

MODE 1: Holds the CAS control signal at the moment of the MAN command.

MODE 2: Goes back the preset time period and hold the CAS control signal at that moment.

MODE 3: Holds a specific value preset by the Programming Unit (PU-2□).

This value can also be changed by utilizing the PU-2□.

With this mode, the output can be manipulated with external UP or DOWN commands.

When the MAN command relay is opened, the CAS control signal is recovered with smooth transition.

■ Transition from Manual to Cascade Control Mode

The JB increases/decreases the MV output until it reaches to the same value as the CAS control signal, and turns on to CAS control mode. The response time constant can be set/changed with the PU-2□.

If the external command relay is closed during the transition, the JB output holds the signal of this moment and turns on to MAN control mode.

■ JB Operations When the Power Supply is Recovered after Failure

Operation Mode before Failure	MAN Command Relay Status at Recovery	When the power is recovered WITHIN the memory time:	When the power is recovered AFTER the memory time:
CASCADE	OFF (CAS mode)	Cascade control	Cascade control
	ON (MAN mode)	Manual control starting with the CAS control signal at the moment of failure	Manual control starting with a specific value preset by PU-2□ (variable by PU-2□)
MANUAL	OFF (CAS mode)	Cascade control	Cascade control
	ON (MAN mode)	Manual control holding the MAN control signal at the moment of failure	Manual control starting with a specific value preset by PU-2□ (variable by PU-2□)
MAN/CAS TRANSITION	OFF (CAS mode)	Cascade control	Cascade control
	ON (MAN mode)	Manual control holding the transition signal at the moment of failure	Manual control starting with a specific value preset by PU-2□ (variable by PU-2□)

APPLICATION EXAMPLES

■ Output Backup Station for a PID Controller in DCS

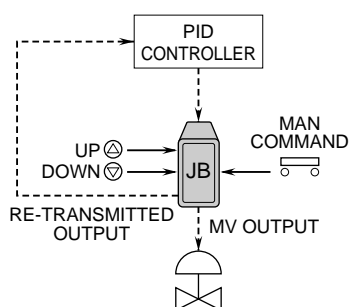

■ Control Loop Utilizing Pulse Duration Output from a Computer

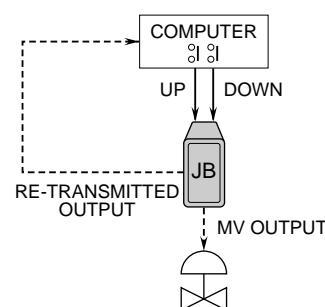

EXTERNAL DIMENSIONS & TERMINAL ASSIGNMENT mm (inch)

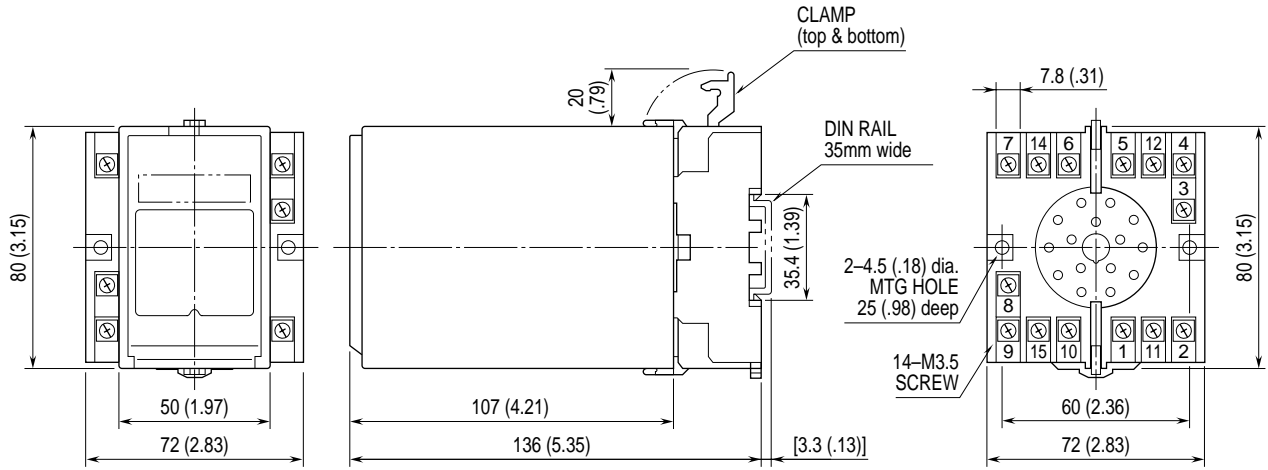

•When mounting, no extra space is needed between units.