

**Plug-in Signal Conditioners M-UNIT****DISCONTINUED MODEL**

Replaced with Model CTS2

**HIGH AC CURRENT TRANSMITTER**

(wide bandwidth)

**Functions & Features**

- Detecting high current at the flexible current probe and providing a proportional low-ripple standard signal appropriate for computer use
- Wide frequency band can be accepted
- Clipped around a conductor without disconnecting the conductor
- Rogowski coil type
- Isolation up to 2000 V AC
- High-density mounting
- CE marking

**Typical Applications**

- Measurement in tight places as never before possible
- Monitoring load current of motors employing inverters
- Detecting failures of a pump or other device by monitoring abnormal load current of motors
- Monitoring current of electric welding machine

**MODEL: CTS-[1][2]-[3]****ORDERING INFORMATION**

- Code number: CTS-[1][2]-[3]

Specify a code from below for each [1] through [3].  
(e.g. CTS-AA-B)

- Special output range (For codes Z & 0)

Default Setting for input range:

30 A for 300 A rating

300 A for 3000 A rating

**[1] INPUT****Current**

**A** : 0 - 300 A AC (30, 60, 150 or 300 A selectable)

**B** : 0 - 3000 A AC (300, 600, 1500 or 3000 A selectable)

**[2] OUTPUT****Current**

**A** : 4 - 20 mA DC (Load resistance 750  $\Omega$  max.)

**B** : 2 - 10 mA DC (Load resistance 1500  $\Omega$  max.)

**C** : 1 - 5 mA DC (Load resistance 3000  $\Omega$  max.)

**D** : 0 - 20 mA DC (Load resistance 750  $\Omega$  max.)

**E** : 0 - 16 mA DC (Load resistance 900  $\Omega$  max.)

**F** : 0 - 10 mA DC (Load resistance 1500  $\Omega$  max.)

**G** : 0 - 1 mA DC (Load resistance 15 k $\Omega$  max.)

**Z** : Specify current (See OUTPUT SPECIFICATIONS)

**Voltage**

**1** : 0 - 10 mV DC (Load resistance 10 k $\Omega$  min.)

**2** : 0 - 100 mV DC (Load resistance 100 k $\Omega$  min.)

**3** : 0 - 1 V DC (Load resistance 100  $\Omega$  min.)

**4** : 0 - 10 V DC (Load resistance 1000  $\Omega$  min.)

**5** : 0 - 5 V DC (Load resistance 500  $\Omega$  min.)

**6** : 1 - 5 V DC (Load resistance 500  $\Omega$  min.)

**4W** : -10 - +10 V DC (Load resistance 2000  $\Omega$  min.)

**5W** : -5 - +5 V DC (Load resistance 1000  $\Omega$  min.)

**0** : Specify voltage (See OUTPUT SPECIFICATIONS)

**[3] POWER INPUT****AC Power**

**B** : 100 V AC

**C** : 110 V AC

**D** : 115 V AC

**F** : 120 V AC

**G** : 200 V AC

**H** : 220 V AC

**J** : 240 V AC

**DC Power**

**S** : 12 V DC

**R** : 24 V DC

**V** : 48 V DC

**P** : 110 V DC (CE marking unavailable)

**GENERAL SPECIFICATIONS****Construction**

**Probe**: Clip-around type

**Transmitter**: Plug-in

**Connection**

**Output & power**: M3.5 screw terminals

**Input**: Connector

**Housing material**

**Probe**: TPE rubber, Polypropylene

**Transmitter**: Flame-resistant resin (black)

**Isolation**: Input to output to power

**Input waveform**

**RMS sensing**: Up to 15 % of 3rd harmonic content

**Overrange output**: 0 to 120 % at 1 - 5 V

**Zero adjustment**: -5 to +5 % (front)

**Span adjustment**: 95 to 105 % (front)

**Input range**: Selectable with the front DIP switch among 30, 60, 150 or 300 A, or 300, 600, 1500 or 3000 A

## INPUT SPECIFICATIONS

Frequency: 4 Hz – 10 kHz (-3 dB)  
 Max. operating voltage: 600 V AC (primary side)  
 Overload capacity: 1000 % of rating for 3 seconds,  
 200 % for 10 seconds, 120 % continuous  
 Operational range: 0 – 120 % of rating

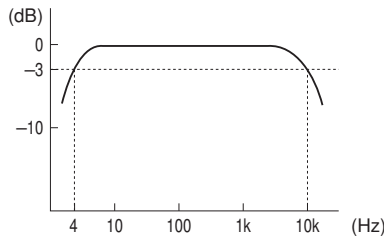

Frequency Characteristics

## OUTPUT SPECIFICATIONS

- **DC Current:** 0 – 20 mA DC

**Minimum span:** 1 mA  
**Offset:** Max. 1.5 times span  
**Load resistance:** Output drive 15 V max.

- **DC Voltage:** -10 – +12 V DC

**Minimum span:** 5 mV  
**Offset:** Max. 1.5 times span  
**Load resistance:** Output drive 10 mA max.; 5 mA for negative voltage output; at  $\geq 0.5$  V

## INSTALLATION

### Power input

- **AC:** Operational voltage range: rating  $\pm 10$  %, 50/60  $\pm 2$  Hz, approx. 2 VA
- **DC:** Operational voltage range: rating  $\pm 10$  %, or 85 – 150 V for 110 V rating (ripple 10 % p-p max.)  
 Approx. 2 W (80 mA at 24 V)

### Operating temperature

**Probe:** -20 to +85°C (-4 to 185°F)  
**Transmitter:** -5 to +60°C (23 to 140°F)

**Operating humidity:** 30 to 90 %RH (non-condensing)

**Mounting:** Surface or DIN rail

### Weight

**Probe:** 200 g (0.44 lbs)  
**Transmitter:** 300 g (0.66 lbs)

## PERFORMANCE in percentage of span

**Accuracy:**  $\pm 1.5$  % at 20 Hz – 1 kHz  
**Repeatability:**  $\pm 0.1$  %  
**Position sensitivity:**  $\pm 1$  %  
**Temp. coefficient:**  $\pm 0.15$  %/°C ( $\pm 0.08$  %/°F)  
**Response time:** 1.5 sec. (0 – 90 %)  
**Ripple:** 0.5 %p-p max.  
**Line voltage effect:**  $\pm 0.1$  % over voltage range

**Insulation resistance:**  $\geq 100$  M $\Omega$  with 500 V DC

**Dielectric strength:** 2000 V AC @1 minute (input to output to power to ground)

## STANDARDS & APPROVALS

### CE conformity:

EMC Directive (2004/108/EC)  
 EMI EN 61000-6-4: 2007  
 EMS EN 61000-6-2: 2005  
 Low Voltage Directive (2006/95/EC)  
 EN 61010-1 (Transmitter, Probe)  
 EN 61010-2-032, EN 61010-031 (Probe)  
 Measurement Category III (input)  
 Installation Category II (power)  
 Pollution Degree 2  
 Input to output or power: Reinforced insulation (600 V)  
 Output to power: Reinforced insulation (300 V)

## EXTERNAL VIEW

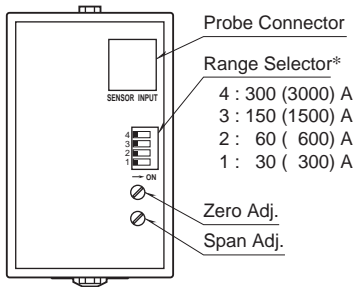

\*( ) for input 3000A type.

## DIMENSIONS unit: mm (inch)

### ■ TRANSMITTER

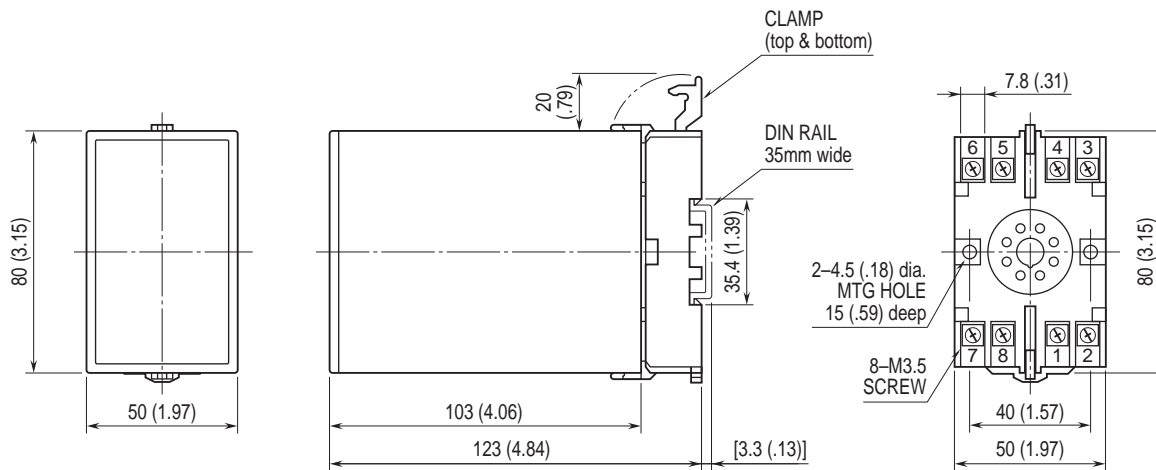

• When mounting, no extra space is needed between units.

### ■ SENSOR

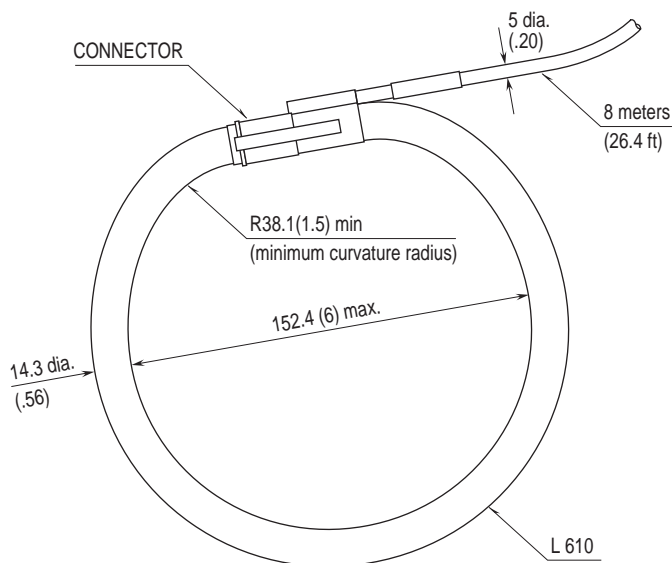

**SCHEMATIC CIRCUITRY & CONNECTION DIAGRAM**

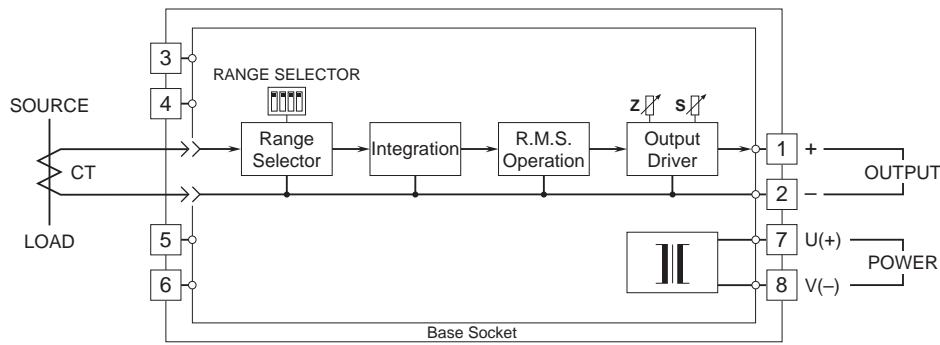

Specifications are subject to change without notice.