

Models M7EASV / M7EASDY

PC CONFIGURATOR SOFTWARE

M7EASCFG

Users Manual

 **M·SYSTEM CO.,LTD.**

Contents

1. INTRODUCTION	3
1.1 GENERAL DESCRIPTION	3
1.2 PC REQUIREMENTS	3
1.3 INSTALLING & UNINSTALLING THE PROGRAM	3
2. GETTING STARTED	4
2.1 STARTING THE M7EASCFG	4
2.2 OPERATING MODES	4
2.3 BASIC OPERATIONS	5
2.3.1 SCREEN COMPONENT IDENTIFICATION	5
2.3.2 READING PARAMETERS SAVED AS FILE	6
2.3.3 SAVING PARAMETERS IN A FILE	6
2.3.4 READING PARAMETERS FROM DEVICE (UPLOAD)	6
2.3.5 WRITING PARAMETERS TO DEVICE (DOWNLOAD)	6
2.3.6 COMPARING PARAMETERS	7
2.3.7 CHANGING PARAMETERS	7
2.3.8 UTILITY	7
2.3.9 TREND GRAPH	8
3. HOW TO SETUP I/O (EXAMPLE)	9
3.1 INPUT RANGE & ALARM SETTING	9
3.1.1 UPLOADING SETTING FROM THE DEVICE	9
3.1.2 INPUT RANGE	9
3.1.3 DISPLAY SCALE RANGE	9
3.1.4 ALARM SETTING	9
3.1.5 DOWNLOADING SETTING TO THE DEVICE	9
3.2 OTHER SETTING	9
4. FUNCTION BLOCKS	10
4.1 GENERAL DESCRIPTIONS	10
4.2 INPUT	11
4.3 INPUT %	11
4.4 INPUT SCALE	12
4.5 L1 through L4	14
4.6 ALARM COMMON	14
4.7 LCD	15
4.8 DEVICE INFO	15

1. INTRODUCTION

1.1 GENERAL DESCRIPTION

M-System M7EASCFG is used to program parameters for models M7EASV DC Alarm and M7EASDY Two-wire Transmitter Alarm (referred hereunder as 'device'). The following major functions are available:

- Edit parameters online (connected to the device) in real time
- Edit parameters offline (not connected to the device)
- Download parameters to the device, upload parameters from the device
- Save parameters as files, read parameters from files
- Compare parameters edited on the screen with the ones stored in the device

1.2 PC REQUIREMENTS

The following PC performance is required for adequate operation of the software program.

PC	IBM PC compatible
CPU	Pentium 120 MHz or higher
Memory	Must meet the relevant Windows' requirements.
Network port	COM port (RS-232C) or USB port (COM1 through COM16)
OS	Windows 98/Me/NT4.0/2000/XP

A non-isolated PC Configurator Cable (model: MCN-CON) is required to connect the device to the PC.

1.3 INSTALLING & UNINSTALLING THE PROGRAM

INSTALL

The program is provided as compressed archive. Uncompress the archive and execute 'setup.exe' to start up the M7EASCFG installer program. Follow instructions on the Windows.

UNINSTALL

Open Control Panel > Add/Remove Programs. Select the M7EASCFG from the program list and click Delete button.

2. GETTING STARTED

2.1 STARTING THE M7EASCFG

Open Program > M-System > Configurator > M7EASV (or M7EASDY) to start up the M7EASCFG on the Windows PC. The following window appears on the screen.



2.2 OPERATING MODES

Two operating modes are available when using the M7EASCFG: Online mode and Offline mode.

In the online mode, the M7EASCFG is connected to the device. Parameters can be edited while monitoring the device operation. New parameters are applied to the device at once.

In the offline mode, the M7EASCFG is not connected to the device. New parameter setting can be created, saved as files to be downloaded later. You can also open such files or upload from the device to edit and then download to the device again.

CONNECTING / DISCONNECTING THE DEVICE

The program's initial state is in offline mode.

- 1) Connect the device to the PC's COM port with the PC Configurator Cable and click [Connect] button at the left top of the screen.
- 2) Choose the COM port number to which the device is connected, and click [OK].
- 3) The device's present parameters are uploaded and shown on the screen.

[Connect] button is now replaced with [Disconnect] button, the bargraphs on the screen show real time I/O status of the device.



In order to go back to the offline mode, click [Disconnect] button.



2.3 BASIC OPERATIONS

2.3.1 SCREEN COMPONENT IDENTIFICATION



(1) Open File / Save File

These buttons are used to read a parameter setting saved in files and to save edited ones as files.

(2) Compare

This button is used to compare edited parameters from actual setting. Clicking [Compare] button shows two sets of parameters: one presently edited on the screen and another uploaded from the connected device.

(3) Upload / Download

These buttons are used to read parameter setting in the device and to write one to the device.

(4) English / Japanese

This button is used to switch the display language. Clicking the button switches between English and Japanese.

The program starts up in English mode as initial state when the OS is other than Japanese version. You can switch to Japanese only when the OS supports Japanese language.

(5) Function Block

These buttons are used to choose Function Block and show parameters selectable in each block.

In online mode, the bargraphs below Function Block buttons show in real time conversion results at each block from Input to Output.

(6) Parameter

Shows all available parameters in the selected Function Block. Click Value cell to change. In online mode, new parameters are applied to the device immediately.

(7) Utility

Shows all available utility buttons in the selected Function Block.

2.3.2 READING PARAMETERS SAVED AS FILE

Clicking [Open File] calls up the Windows-standard Open dialog box. Select a parameter file to show a stored parameter setting.

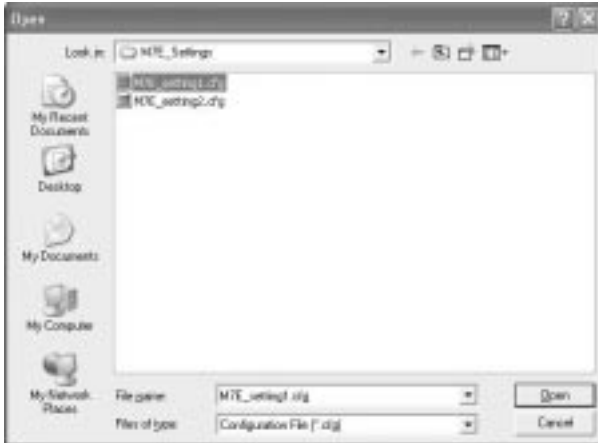

In online mode, the parameters are automatically downloaded at the same time to the connected device.

2.3.3 SAVING PARAMETERS IN A FILE

Clicking [Save File] calls up the Windows-standard Save As dialog box. Enter a desired file name to File Name field and click [Save] to store a parameter setting.



2.3.4 READING PARAMETERS FROM DEVICE (UPLOAD)

Clicking [Upload] starts reading parameters stored in the connected device to show them on the screen. Specify the COM port of the device and click [OK].

2.3.5 WRITING PARAMETERS TO DEVICE (DOWNLOAD)

Clicking [Download] starts writing parameters edited on the screen to the connected device. Specify the COM port of the device and click [OK].

2.3.6 COMPARING PARAMETERS

Parameters presently edited on the screen and those stored in the connected device can be compared side by side. Edited parameters could be from a file if you open one in advance, or another device if you uploaded one in advance.

Clicking [Compare] button starts reading parameters from the connected device. Parameters are compared and listed on the screen side by side. The rows showing differences between two sets of parameters are highlighted in red background. The total number of non-matching cases is mentioned at the bottom.

Function Block	Parameter Name	Edited Value	Device Value
Input %	Input calibration	1000	1000
Input Scale	Fine Adjust. 0%	0.00	0.00
Input Scale	Fine Adjust. 1% ..	1.000	1.000
Input Scale	Device Offset	21.00.00	21.00.00
Input Scale	Scaling 0%	0.00	0.00
Input Scale	Scaling 100%	90.00	90.00
Input Scale	Scaling Unit	100C	100C
L1	Alarm Value	20.00	20.00
L1	Trip Operation	Lo	Lo
L1	Hysteresis	1.00	1.00
L1	Call at Alarm	Emergency	Emergency
L2	Alarm Value	30.00	30.00
L2	Trip Operation	Lo	Lo
L2	Hysteresis	1.00	1.00
L2	Call at Alarm	Emergency	Emergency
L3	Alarm Value	70.00	70.00
L3	Trip Operation	H	H
L3	Hysteresis	1.00	1.00
L3	Call at Alarm	Emergency	Emergency
L4	Alarm Value	80.00	80.00
L4	Trip Operation	H	H
L4	Hysteresis	1.00	1.00
L4	Call at Alarm	Emergency	Emergency
Alarm Common	Power ON Delay	5	5
Alarm Common	Alarm ON Delay	0	0
Alarm Common	Latching	Disable	Disable
LCD	Contrast	50	50
LCD	Back Light	ON	ON
LCD	Back Light Off T...	30	30

2 parameter(s) not matching.

2.3.7 CHANGING PARAMETERS

Choose a Function Block to show all available parameters in the list to the right. Click Value cell to change.

For example, when you want to change input type, choose Input function block and click Value cell for Input Type parameter. Then an arrow appears to show you the pulled-down menu list. Choose one from the list.

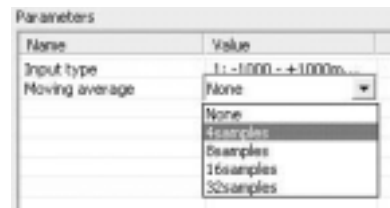

Another example is to change the input filter's time constant. Choose Input Value function block and click Value cell for Filter Time Constant. Then an edit box appears in the cell. Enter a desired value and press Enter key on the keyboard.

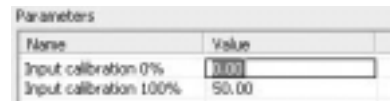

2.3.8 UTILITY

Utility functions are available to help changing parameters and to monitor the device operation on a trend graph.

Choose a Function Block to show all available Utility functions.

Some utility functions affect the device operation immediately, others call up dialog boxes to interface with the user. For detailed explanations, please refer to Section 4. FUNCTION BLOCKS.

2.3.9 TREND GRAPH

Function Blocks which are used to convert one value to another such as Input Value have Trend Graph function. The trend is recorded and displayed in 0.5 second intervals.

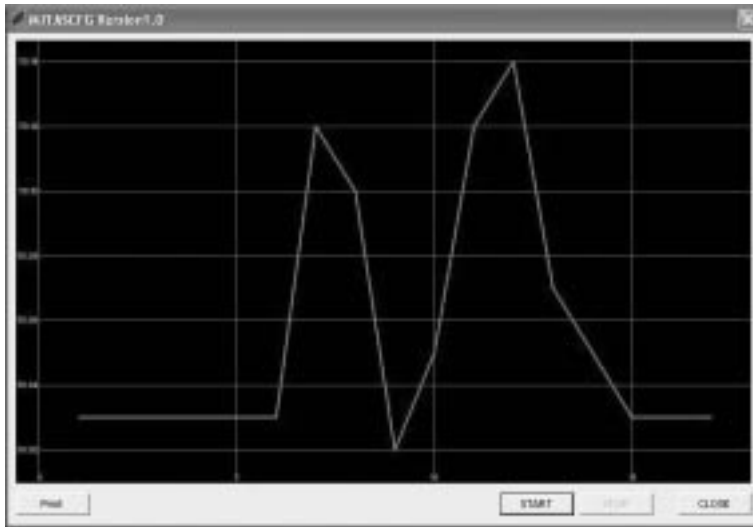

Click [Start] to start recording and displaying in real time.

Click [Stop] to stop monitoring, and the recorded trend graph can be studied more closely by scrolling and enlarging the screen:

Mouse	Screen
Press left mouse button and drag	Scrolls the screen to all directions.
Press right mouse button and drag	Forms an area on the screen to enlarge and fit it to the full-screen area when the mouse button is released.
Double-click left mouse button	Display range is reduced by half (trend curve is zoomed in).
Double-click right mouse button	Display range is doubled (trend curve is zoomed out).

3. HOW TO SETUP I/O (EXAMPLE)

Basic setup procedure including the input range setting and the alarm setting is as in the following.

Values as shown below are used as example:

Factory setting:	4 – 20mA DC input, Dual SPDT relay output
New setting	
Input:	0 – 50mA DC
Display scale:	0.0 – 100.0
Alarm setting:	L1 = Lo trip at 10.0, L2 = Hi trip at 80.0.

3.1 INPUT RANGE & ALARM SETTING

3.1.1 UPLOADING SETTING FROM THE DEVICE

Start up the M7EASCFG software and click [Upload] button. Choose the COM port to which the device is connected and click [OK]. Present parameter setting is uploaded and displayed on the screen. Now you can change the parameters.

3.1.2 INPUT RANGE

Click [Input %] Function Block. Enter the scaled 0% and 100% range values. Use the same engineering unit as for the type.

For 0-50 mAdc input, set 0.00 to '0% input' and 50.00 to '100% input.'

3.1.3 DISPLAY SCALE RANGE

Click [Input Scale] Function Block.

First, choose '1 : XXX.X' for 'Decimal Point.'

Then, set 0.0 to 'Scaling 0%' and 100.0 to 'Scaling 100%.'

3.1.4 ALARM SETTING

Click [L1] Function Block to specify the Lo alarm trip.

Set 10.0 to 'Alarm Value' and choose 'Lo' or 'Trip Operation.'

Then, click [L2] Function Block to specify the Hi alarm trip.

Set 80.0 to 'Alarm Value' and choose 'Hi' for 'Trip Operation.'

3.1.5 DOWNLOADING SETTING TO THE DEVICE

Click [Download] button. Choose the COM port to which the device is connected and click [OK]. The new parameter setting edited on the screen is downloaded to the device.

3.2 OTHER SETTING

The device has more variety of functions than explained in the previous sections, including filter time constant setting and hysteresis. Basic procedure is mostly the same as the above example. For detailed explanations, please refer to Section 4. FUNCTION BLOCKS.

4. FUNCTION BLOCKS

4.1 GENERAL DESCRIPTIONS

The M7EASV/M7EASDY performs several internal conversion processes before supplying the output signals. Each conversion process is called 'Function Block.' The M7EASV/M7EASDY has nine (9) Function Blocks to perform conversions from input to output.

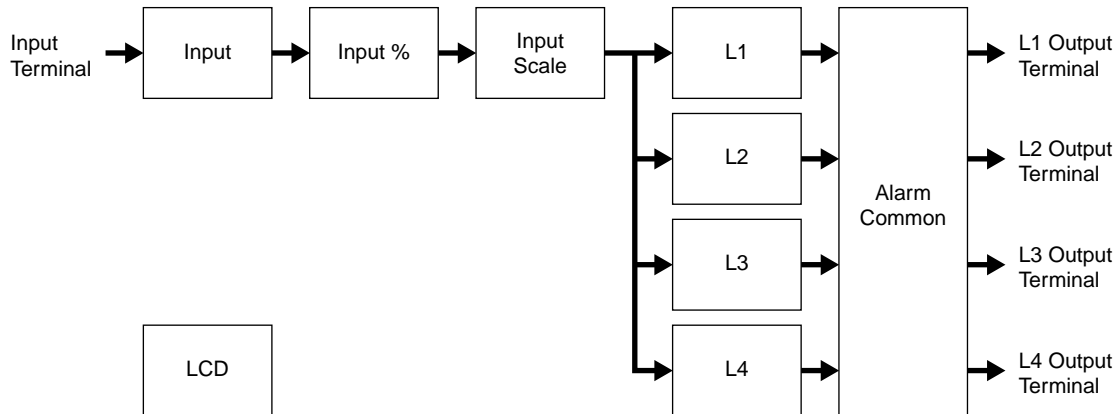

Each block is connected in series from input to output. DC voltage/current supplied at the input terminals is provided to Input Function Block, converted and transferred from block to block in turn, and distributed to four blocks which perform alarm functions. Each result is supplied to the output terminals through Alarm Common Function Block.

Each block stores its particular conversion results. User can visually confirm each block's conversion function by referring to these results. For example, Input Function Block stores actual engineering unit value (V or mA).

Parameters listed to right side of the screen affect the conversion results, i.e. the device's conversion characteristics can be changed by setting up these parameters.

Basic functions of each Function Block are listed as below:

(1) Input

Determines input signal type at the external terminals. This block converts the input voltage/current into the internal digital data.

(2) Input %

Scales the input data to 0 to 100% range. Choose actual device's input range (e.g.: 1 to 5 Vdc) in this block.

(3) Input Scale

Scales the input % data to an engineering unit range used to display on the LCD.

(4) L1 through L4

Compares the input scale value with respective trip types and setpoints.

(5) Alarm Common

Determines output alarm signals at the external L1...L4 terminals.

(6) LCD

Specifies the LCD related parameters. This block is independent from others.

4.2 INPUT

Determines input signal type at the external terminals. This block converts the input voltage/current into the internal digital data.

Parameter

Name	Explanations
Input type	This parameter is determined by the M7EASV's model suffix code, and thus not selectable on this software program, except when a new file is created offline: 0 : 0 - 50mA DC 1 : -1000 - +1000mV DC 2 : -10 - +10V DC The input type is fixed at 0 - 20mA DC for the M7EASDY.
Moving average	Moving average filter is applicable to the input signal in order to eliminate input spikes. Number of samples are selectable from: None, 4 samples, 8 samples, 16 samples and 32 samples.

Utility

Name	Explanations
Trend graph	Shows the trend graph of Input Value.

4.3 INPUT %

Scales the input data to 0 to 100% range. Operational range is -7.5 to +107.5%. Input signals exceeding the limits are rounded to -7.5% and +107.5% respectively .

Parameter

Name	Explanations
Input calibration 0%	Enter the engineering unit value equivalent to 0% input. For example, entering 1.000 with the input type $\pm 10V$ means that 1.000V is converted as 0% input, i.e. 0% input equals to 1.000V.
Input calibration 100%	Enter the engineering unit value equivalent to 100% input. For example, entering 5.000 with the input type $\pm 10V$ means that 5.000V is converted as 100% input, i.e. 100% input equals to 5.000V.
Low cut point	(M7EASDY only) Input signals below the low-cut point is forcibly handled as 0%. The low-cut point has a hysteresis of 0.2%. When the input signal increases, the point is exactly at the setpoint, though when the signal decreases, the point is at the setpoint minus 0.2%. With the square root extraction setting, the signal is handled linearly below the setpoint.

• Linear or User Table

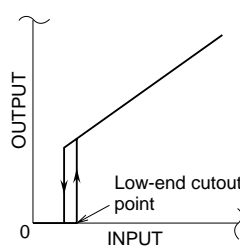

• Square Root

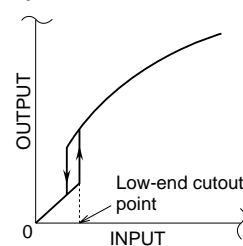

Utility

Name	Explanations
Trend graph	Shows the trend graph of Input %.

4.4 INPUT SCALE

Scales input % data into an engineering unit scale range.

Parameter

Name	Explanations
Fine adj. 0%/100%	Input % data can be finely adjusted before it is converted into a scaled range. $[\text{Input data supplied to scaling}] = ([\text{Input \%}] + [\text{Fine Adj. 0\%}]) \times [\text{Fine Adj. 100\%}]$ -99.99 to +99.99% adjustable for the zero bias, 0.000 to 9.999 adjustable for the span gain.
Decimal point	Enter the number of decimal places for the display scale, from 0 to 3. Internal data is stored as integer within -9999 to 9999. This decimal point position is simply applied for setting and displaying in the scaled range. For example, 1000 is displayed as 1000 with the decimal point position set to 0, as 10.00 with that set to 2. This setting is used to change the display range, does not affect alarm trip operation.
Scaling 0%	Enter the lower range display value for 0% input. For example, setting -1.000 means that the input % value is converted into -1.000.
Scaling 100%	Enter the lower range display value for 100% input. For example, setting 5.000 means that the input % value is converted into 5.000.
Scaling unit	Enter the engineering unit. ASCII code plus special characters (10 types)* are usable. *Special characters are displayed correctly only on the device LCD. On this software window, these characters are represented as '\ ' plus two-digit numbers as indicated below. For example, enter '\80C' for '°C.'

Code	80	81	82	83	84	85	86	87	88
Character	°	∅	²	³	·	Ω	μ	↑	↓

Linearizer	(M7EASDY only) Choose one of the following I/O characteristics. Linear : Input is proportionally converted into the scaling values. Sqrt : Input is square-root extracted into the scaling values. User Table : Input is linearized by using the user table specifying relationship between Input % (X) and Output % (Y).
------------	---

X[0], Y[0] ... X[127], Y[127] (M7EASDY only)	Specify the calibration points for User Table linearization. The output is scaled to Y value for each X (Input %) value. Data between two points are linearly approximated. When there is only one point for reference (data out of the table range), the closest Y value is used.
--	---

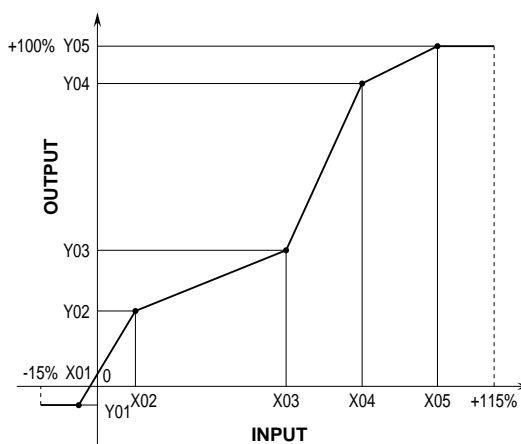

Utility

Name	Explanations
Trend graph	Shows the trend graph for the input scale range.
Table File	Linearization tables are created and saved as files. Clicking [Table File] button opens the Table File window.

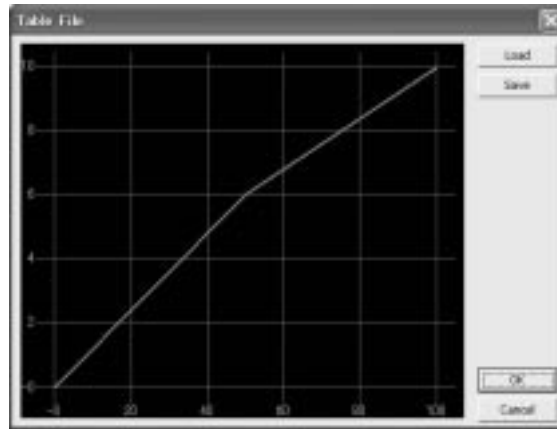

The graph shows the presently edited table. X axis represents Input %, while Y axis represents Output %.

Click [Load] in this window to show a pre-defined table data.

Click [Save] in this window to save the edited table data as files.

Click [OK] to apply the edited table data.

Click [Cancel] to quit the window without apply the edited table data.

4.5 L1 through L4

Compares the input scale value with respective trip types and setpoints.

Parameter

Name	Explanations																								
Alarm value	Enter the threshold value in engineering unit. Selectable from -9999 to +9999.																								
Trip operation	Specify either Hi alarm trip or Lo alarm trip.																								
Hysteresis	Enter the hysteresis (deadband) value in engineering unit. Selectable within the scaled input span. Once an alarm is tripped, it is not reset until the input signal again goes below (for Hi trip) or above (for Lo trip) the threshold by the hysteresis (deadband) values.																								
Coil at Alarm	The relay coil can be energized or de-energized when the alarm is tripped. Relay contact status in various operating conditions according to this setting is as shown below: <table border="1" data-bbox="571 645 1396 806"> <thead> <tr> <th rowspan="2">Conditions</th> <th colspan="2">N.O Contact</th> <th colspan="2">N.C. Contact</th> </tr> <tr> <th>Coil Energized</th> <th>Coil De-energized</th> <th>Coil Energized</th> <th>Coil De-energized</th> </tr> </thead> <tbody> <tr> <td>Alarm</td> <td>Closed</td> <td>Open</td> <td>Open</td> <td>Closed</td> </tr> <tr> <td>Normal</td> <td>Open</td> <td>Closed</td> <td>Closed</td> <td>Open</td> </tr> <tr> <td>Power OFF</td> <td>Open</td> <td>Open</td> <td>Closed</td> <td>Closed</td> </tr> </tbody> </table>	Conditions	N.O Contact		N.C. Contact		Coil Energized	Coil De-energized	Coil Energized	Coil De-energized	Alarm	Closed	Open	Open	Closed	Normal	Open	Closed	Closed	Open	Power OFF	Open	Open	Closed	Closed
Conditions	N.O Contact		N.C. Contact																						
	Coil Energized	Coil De-energized	Coil Energized	Coil De-energized																					
Alarm	Closed	Open	Open	Closed																					
Normal	Open	Closed	Closed	Open																					
Power OFF	Open	Open	Closed	Closed																					

Utility

Name	Explanations
Alarm test	The output relay contact can be manual turned on and off regardless of the input signal for testing.

4.6 ALARM COMMON

Determines output alarm signals at the external L1...L4 terminals.

Parameter

Name	Explanations
Power ON delay timer	Alarm trip operations are cancelled for the preset time period after the power has been supplied to the unit and the LCD's initial view has been displayed. Selectable from 0 to 99 seconds.
Alarm ON delay timer	An alarm relay does not trip unless its alarm condition is maintained for the preset time period. The alarm ON delay time can be selectable from 0 to 999 seconds independently for each setpoint.
Latching	A latching alarm relay does not reset once it has been tripped, even when the signal goes out of the alarm range. In order to reset, turn the off power supply to the unit, or disable the latching setting.

Utility

None available

4.7 LCD

Specifies the LCD related parameters. This block is independent from others.

Parameter

Name	Explanations
Contrast	Specify within a range from 0 (lowest) to 100 (highest).
Back light	Three backlight modes (orange backlight) are available: On The backlight is always On. Off The backlight is always Off. Off Timer The backlight automatically turns off after the preset time if the front control buttons remain untouched. Red backlight turns on in alarm conditions regardless of the above setting.
Back light OFF time	Specifies a time for the backlight to be turned off when the Off Timer is selected. Enter a value in seconds between 1 and 3600.

Utility

None available

4.8 DEVICE INFO

Device information is available for reference while the device is connected online. This button is not usable while other functions such as Open File, Save File, Compare, are activated.

Parameter

Name	Explanations
Model	Model number of the device
Firmware	Firmware revision number of the device
Serial	Serial number of the device
Tag No.	Tag name. This parameter is the only selectable one among Device Info. Max. 10 alphanumeric characters. Characters exceeding this limit are ignored. The usable characters are the same with Scaling unit. Please refer to Section 4.4 INPUT SCALE.

M-SYSTEM WARRANTY

1. What is covered.

M-System Co., Ltd. ("M-System") warrants, only to the original purchaser of new M-System products purchased directly from M-System, or from M-System's authorized distributors or resellers, for its own use not for resale, that the M-System products shall be free from defects in materials and workmanship and shall conform to the specifications set forth in the product catalogue applicable to the M-System products for the Warranty Period (see Paragraph 5 below for the Warranty Period of each product).

THE ABOVE WARRANTY IS THE ONLY WARRANTY APPLICABLE TO THE M-SYSTEM PRODUCTS AND IS IN LIEU OF ALL OTHER WARRANTIES, EXPRESS OR IMPLIED, INCLUDING, BUT NOT LIMITED TO, ALL IMPLIED WARRANTIES OF MERCHANTABILITY OR OF FITNESS FOR A PARTICULAR PURPOSE.

2. What is not covered.

This warranty does not cover any M-System product which has been: (1) modified, altered or subjected to abuse, misuse, negligence or accident; (2) improperly installed or installed in conjunction with any equipment for which it was not designed; or (3) damaged or destroyed by disasters such as fire, flood, lightning or earthquake.

In no event shall M-System be liable for any special, incidental, consequential or other damages, costs or expenses (including, but not limited to, loss of time, loss of profits, inconvenience or loss of use of any equipment).

3. Remedies.

If a defective product is returned to M-System in accordance with the procedures described below, M-System will, at its sole option and expense, either: (1) repair the defective product; (2) replace the defective product; or (3) refund the purchase price for the defective product paid by the purchaser. Except as otherwise provided by applicable state law, these remedies constitute the purchaser's **sole and exclusive** remedies and M-System's sole and exclusive obligation under this warranty.

4. Warranty Procedure.

If the purchaser discovers a failure of the M-System products to conform to the terms of this warranty within the Warranty Period, the purchaser must promptly (and, in any event not more than 30 days after the discovery of such failure) notify the relevant party as described below either by telephone or in writing at the below address to obtain an Authorized Return (AR) number and return the defective product to the relevant party. The designated AR number should be marked on the outside of the return package and on all correspondence related to the defective product. The purchaser shall return, at purchaser's expense, defective products only upon receiving an AR number. In order to avoid processing delays, the purchaser must include: copies of the original purchase order and sales invoice; the purchaser's name, address and phone number; the model and serial numbers of the returned product; and a detailed description of the alleged defect.

5. Warranty Period.

Signal Conditioner:	36 months from the date of purchase.
M-Rester:	12 months from the date of purchase.
Valve Actuator:	18 months from the date of shipment from M-System or 12 months from the date of its installation, whichever comes first.
Other Products:	36 months from the date of purchase.

M-SYSTEM CO., LTD.

5-2-55, Minamitsumori, Nishinari-ku,

Osaka 557-0063 JAPAN

Phone: (06) 6659-8201

Fax: (06) 6659-8510

E-mail: info@m-system.co.jp



5-2-55, Minamitsumori, Nishinari-ku, Osaka 557-0063 JAPAN

Tel: +81-6-6659-8201 Fax: +81-6-6659-8510

<http://www.m-system.co.jp>

E-mail: info@m-system.co.jp