

FREQUENCY TRANSMITTER

(PC programmable)

MODEL **M2XPA2**

BEFORE USE

Thank you for choosing M-System. Before use, please check contents of the package you received as outlined below.

If you have any problems or questions with the product, please contact M-System's Sales Office or representatives.

■ PACKAGE INCLUDES:

Signal conditioner (body + base socket) (1)

■ MODEL NO.

Confirm Model No. marking on the product to be exactly what you ordered.

■ INSTRUCTION MANUAL

This manual describes necessary points of caution when you use this product, including installation, connection and basic maintenance procedures.

To change I/O ranges, the JX Configurator Connection Kit (model: JXCON) is required. For detailed information, refer to the data sheet and instruction manual for the JXCON.

POINTS OF CAUTION

■ NONINCENDIVE APPROVAL OPTION

- This equipment is suitable for use in Class I, Div. 2, Groups A, B, C and D or Non-Hazardous Locations only.
- **WARNING!** Before You Remove the Unit from Its Base Socket or Mount It, Turn Off the Power Supply and Input Signal for Safety.
- **WARNING!** – Explosion Hazard – Substitution of Components May Impair Suitability for Class I, Div. 2.
- **WARNING!** – Explosion Hazard – Do Not Disconnect Equipment Unless Power Has Been Switched Off or The Area is Known To Be Non-Hazardous.
- The equipment was evaluated for use in the ambient temperature and relative humidity as mentioned in 'ENVIRONMENT' section.
- The input and output wiring must be in accordance with Class I, Div. 2 wiring methods and in accordance with the authority having jurisdiction for use in these hazardous locations.

■ CONFORMITY WITH EC DIRECTIVES OR UL

- This equipment is suitable for use in a Pollution Degree 2 environment and in Installation Category II, with the maximum operating voltage of 300V.
Basic insulation is maintained between signal input and output. The voltage across the input terminals is limited to 70V or less. Prior to installation, check that the insulation class of this unit satisfies the system requirements.
- Altitude up to 2000 meters
- The equipment must be mounted inside a panel.
- Risk of Electrical Shock: The front cover of the panel is to be opened only by qualified service personnel.
- The equipment must be installed such that appropriate clearance and creepage distances are maintained to conform to CE/UL requirements. Failure to observe these requirements may invalidate the CE/UL conformance.

■ POWER INPUT RATING & OPERATIONAL RANGE

- Locate the power input rating marked on the product and confirm its operational range as indicated below:
100 – 240V AC rating: 85 – 264V (90 – 264V for UL),
47 – 66 Hz, approx. 4 – 6VA
24V DC rating: 24V ±10%, approx. 3W
110V DC rating: 85 – 150V (110V ±10% for UL), approx. 3W

■ WARNING!

- To protect very delicate components contained inside the unit against damage from static electricity, wear a grounded wrist strap when handling them. If you do not have one, touch both of your hands to a safely grounded object or to a metal object.
- Ensure that the power supply and input signal are switched off before you plug in or remove the unit.

■ ENVIRONMENT

- Indoor use
- When heavy dust or metal particles are present in the air, install the unit inside proper housing with sufficient ventilation.
- Do not install the unit where it is subjected to continuous vibration. Do not subject the unit to physical impact.
- Environmental temperature must be within -5 to +55°C (23 to 131°F) with relative humidity within 30 to 90% RH in order to ensure adequate life span and operation.
- Be sure that the ventilation slits are not covered with cables, etc.

■ WIRING

- Do not install cables (power supply, input and output) close to noise sources (relay drive cable, high frequency line, etc.).
- Do not bind these cables together with those in which noises are present. Do not install them in the same duct.

■ AND

- The unit is designed to function as soon as power is supplied, however, a warm up for 20 minutes is required for satisfying complete performance described in the data sheet.

COMPONENT IDENTIFICATION

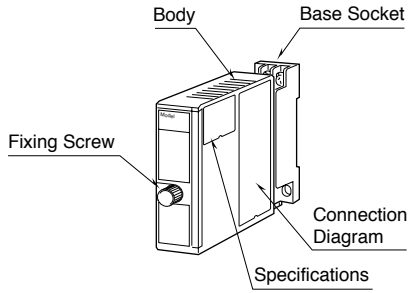

■ HOW TO OPEN THE LEFT SIDE COVER

Insert the tip of a minus driver into the openings indicated with arrows in the figure, and pull up the cover.

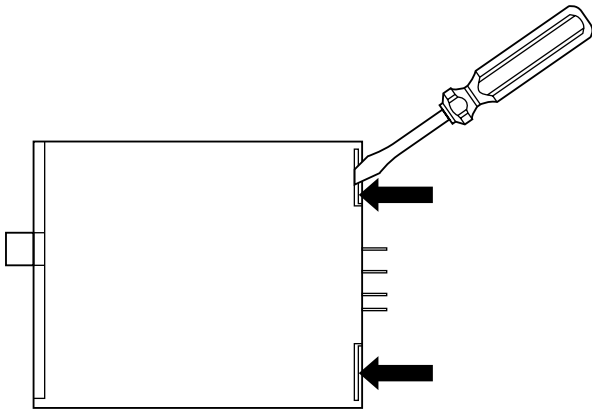

■ HOW TO CLOSE THE LEFT SIDE COVER

Place the side A first and push in the parts B, gently not to break the enclosure.

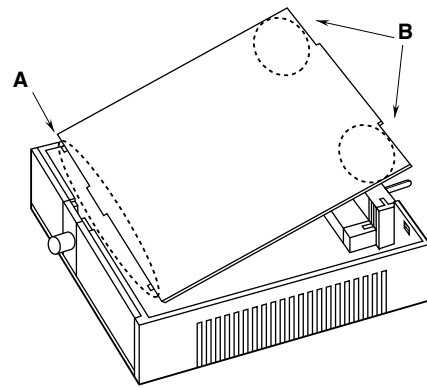

INSTALLATION

Loosen the fixing screw at the front of the unit in order to separate the body from the base socket.

■ DIN RAIL MOUNTING

Set the base socket so that its DIN rail adaptor is at the bottom. Position the upper hook at the rear side of base socket on the DIN rail and push in the lower. When removing the socket, push down the DIN rail adaptor utilizing a minus screwdriver and pull.

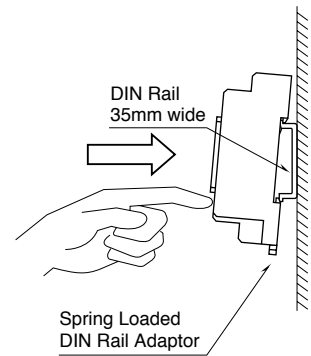

■ WALL MOUNTING

Refer to 'EXTERNAL DIMENSIONS.'

EXTERNAL DIMENSIONS unit: mm (inch)

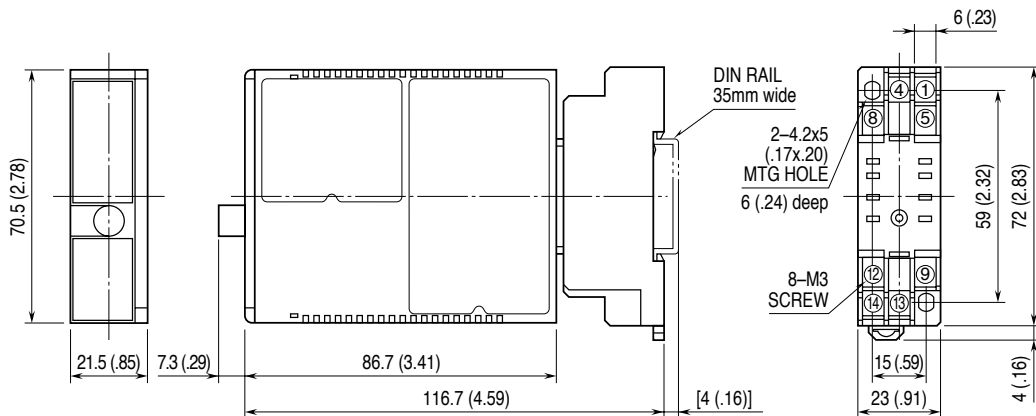

• When mounting, no extra space is needed between units.

TERMINAL CONNECTIONS

Connect the unit as in the diagram below or refer to the connection diagram on the side of the unit.

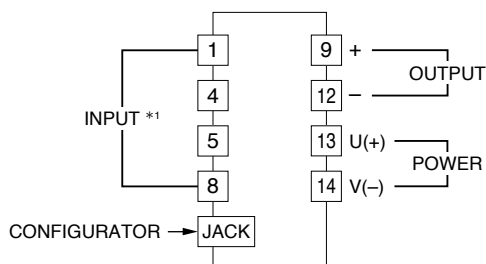

*1. Input Connection Examples

■ Dry Contact

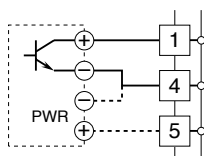

■ Voltage Pulse

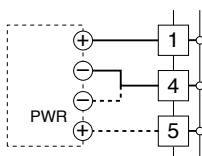

■ Mechanical Contact

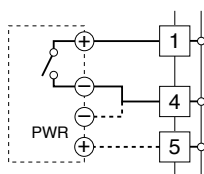

■ RS-422 Line Driver Pulse

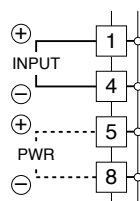

■ 2-Wire Current Pulse

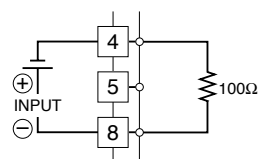

Zero and span are respectively set to 0% and 100% at the factory.

■ FRONT VIEW (with cover open)

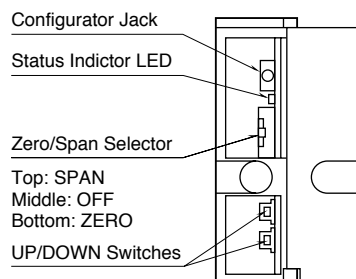

The front cover cannot be opened to 180 deg. when flush with neighboring units.

Zero/Span Selector

ZERO: UP/DOWN switches usable for zero adjustment.

OFF: UP/DOWN switches unavailable.

SPAN: UP/DOWN switches usable for span adjustment.

UP/DOWN Switches

UP: Pressing UP increases adjusted values.

DOWN: Pressing DOWN decreases adjusted values.

■ HOW TO CALIBRATE THE ZERO

Slide the Zero/Span Selector to the bottom position and press UP or DOWN switch. Incrementing speed will be doubled when you keep pressing a switch.

■ HOW TO CALIBRATE THE SPAN

Slide the Zero/Span Selector to the top position and press UP or DOWN switch. Incrementing speed will be doubled when you keep pressing a switch.

■ HOW TO RESET

After you calibrated manually with these switches, you can reset them to its ex-factory state by pressing both UP/DOWN switches at once.

■ ADJUSTMENT PROCEDURE

Use a signal source and measuring instruments of sufficient accuracy level. Turn the power supply on and warm up for more than 20 minutes.

1) **ZERO:** Apply 0% input. Slide the Zero/Span Selector to the bottom position. Press UP or DOWN switch and adjust output to 0%.

2) **SPAN:** Apply 100% input. Slide the Zero/Span Selector to the top position. Press UP or DOWN switch and adjust output to 100%.

3) Check ZERO adjustment again with 0% input.

4) The ZERO and SPAN adjustments are processed in a digital processor, and therefore they do not interact. However, if ZERO value is changed, repeat the above procedure 1) – 3).

CHECKING

- 1) Terminal wiring: Check that all cables are correctly connected according to the connection diagram.
- 2) Check DIP switch setting.
- 3) Power input voltage: Check voltage across the terminal 13 – 14 with a multimeter.
- 4) Input: Check that the input voltage is within 0 – 100% of full-scale.
- 5) Output: Check that the load resistance meets the described specifications.
- 6) Status indicator LED: Check that it flashes in the normal patterns.

ZERO/SPAN ADJUSTMENTS

This unit is calibrated at the factory to meet the ordered specifications, therefore you usually do not need any calibration.

For matching the signal to a receiving instrument or in case of regular calibration, fine zero and span adjustments can be done to $\pm 5\%$ by pressing UP/DOWN switches enabled with the zero/span selector switch. Calibrated values are stored in the non-volatile memory, which will not be lost even when you turn off power supply to the unit.

ADJUSTING DETECTING LEVEL (voltage pulse, two-wire current pulse only)

Appropriate detecting level is determined according to the flow chart below.

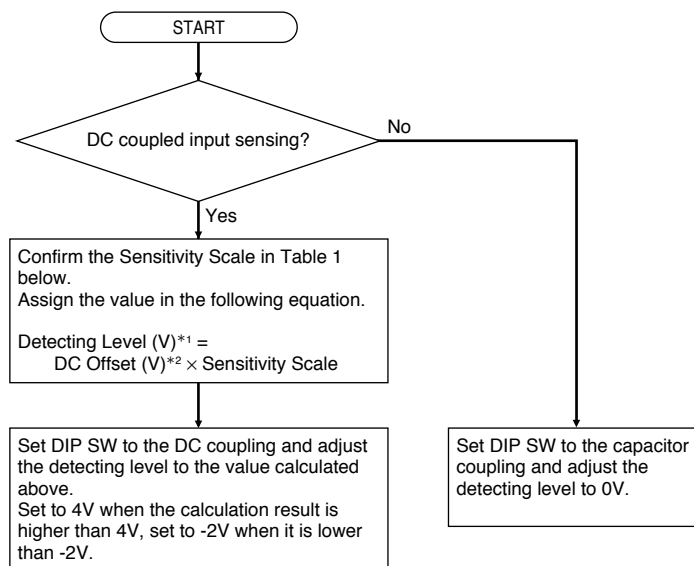

*1. Rounded off to two decimal places.

*2. Divide a current input (mA) by 10 and convert it into voltage (V).
e.g. Offset = 10mA --> 10mA x 1/10 = 1V

Table 1

PULSE AMPLITUDE	SENSITIVITY SCALE
50 – 100V p-p	1/20
25 – 50V p-p	1/10
10 – 25V p-p	1/5
5 – 10V p-p	1/2
1 – 5V p-p	1
0.5 – 1V p-p	1
0.1 – 0.5V p-p	1

A specific sensitivity scale is applied according to the pulse amplitude by setting up the DIP switch and PC Configuration Software. The scaled input voltage is then compared to the detecting level at -2.00 through +4.00V.

With DC coupling, the scaled maximum input voltage level must be higher than and the scaled minimum input voltage level must be lower than the detecting level so that the pulse state is accurately detected.

• Setting Examples

Voltage Input (DC Offset = Pulse Amplitude / 2)

PULSE AMPLITUDE (Vp-p)	AMPLITUDE RANGE (Vp-p)	DETECTING LEVEL (V)
100	50 – 100	2.5
50	25 – 50	2.5
30	25 – 50	1.5
25	10 – 25	2.5
15	10 – 25	1.5
10	5 – 10	2.5
7.5	5 – 10	1.9
5	1 – 5	2.5
3.5	1 – 5	1.75
2	1 – 5	1
1	0.5 – 1	0.5
0.5	0.1 – 0.5	0.25

Current Input (DC Offset = Pulse Amplitude / 2)

PULSE AMPLITUDE (mA p-p)	AMPLITUDE RANGE (Vp-p)	DETECTING LEVEL (V)
16 (1.6Vp-p)	1 – 5	0.8
25 (2.5Vp-p)	1 – 5	1.25

CHANGING I/O TYPE & RANGE

Input type and range, and output type and range can be programmed on the Configuration Software. Additionally, when changing the input type, hardware settings are needed as explained below.

■ LEFT SIDE VIEW (with cover removed)

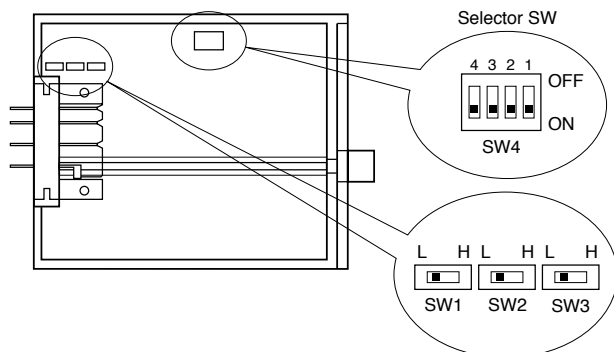

■ DIP SWITCH SETTINGS

• Input Type

Table 2

INPUT	SW1	SW2	SW3
Open Collector	H	H	H
Mechanical Contact	H	H	H
Voltage Pulse	H	H	H
Two-wire Current Pulse	H	H	H
RS-422 Line Driver Pulse	L	L	L

• Pulse Sensing

Table 3

SENSING	SW4-3
Capacitor Coupled	OFF
DC Coupled	ON

• Noise Filter

Table 4



FILTER	SW4-2	SW4-1
Large (time constant 50 ms)	ON	OFF
Small (time constant 10 ms)	OFF	ON
Without	OFF	OFF

STATUS INDICATOR LED

The M2XPA2 is provided with a status indicator LED which flashes in different patterns indicating various status of its CPU.

When it is functioning within normal parameters, the LED flashes in a regular pattern of ON and OFF. The high levels mean that the light is ON for 500 millise., while the low levels means OFF for 500 millise. as shown in the figure below.

When the unit is in an abnormality, it flashes in particular patterns repeating approximately in 4 seconds.

Normal Mode
PC configuration complete; Operating normally
LED Patterns 
Abnormal Mode
CPU Communication Error
LED Patterns 

MAINTENANCE

Regular calibration procedure is explained below:

■ CALIBRATION

Warm up the unit for at least 20 minutes. Apply 0%, 25%, 50%, 75% and 100% input signal. Check that the output signal for the respective input signal remains within accuracy described in the data sheet. When the output is out of tolerance, recalibrate the unit according to the "ADJUSTMENT PROCEDURE" explained earlier.

M-SYSTEM WARRANTY

M-System warrants such new M-System product which it manufactures to be free from defects in materials and workmanship during the 36-month period following the date that such product was originally purchased if such product has been used under normal operating conditions and properly maintained, M-System's sole liability, and purchaser's exclusive remedies, under this warranty are, at M-System's option, the repair, replacement or refund of the purchase price of any M-System product which is defective under the terms of this warranty. To submit a claim under this warranty, the purchaser must return, at its expense, the defective M-System product to the below address together with a copy of its original sales invoice.

THIS IS THE ONLY WARRANTY APPLICABLE TO M-SYSTEM PRODUCT AND IS IN LIEU OF ALL OTHER WARRANTIES, EXPRESS OR IMPLIED, INCLUDING ANY IMPLIED WARRANTIES OF MERCHANTABILITY OR FITNESS FOR A PARTICULAR PURPOSE. M-SYSTEM SHALL HAVE NO LIABILITY FOR CONSEQUENTIAL, INCIDENTAL OR SPECIAL DAMAGES OF ANY KIND WHATSOEVER.

M-System Co., Ltd., 5-2-55, Minamitsumori, Nishinari-ku, Osaka 557-0063 JAPAN, Phone: (06) 6659-8201, Fax: (06) 6659-8510, E-mail: info@m-system.co.jp